



Control Console

User's Manual



1241 Bundy Boulevard, Winona, Minnesota USA
Phone: +1 (507) 454-5300, Fax: +1 (507) 452-4507 <http://www.watlow.com>

**TOTAL
CUSTOMER
SATISFACTION**
3 Year Warranty

ISO 9001



Registered Company
Winona, Minnesota USA

0600-0045-0000 Rev C



March 2004

\$5.00

Safety Information

We use note, caution and warning symbols throughout this book to draw your attention to important operational and safety information.

A "NOTE" marks a short message to alert you to an important detail.

A "CAUTION" safety alert appears with information that is important for protecting your equipment and performance. Be especially careful to read and follow all cautions that apply to your application.

A "WARNING" safety alert appears with information that is important for protecting you, others and equipment from damage. Pay very close attention to all warnings that apply to your application.

The safety alert symbol,  (an exclamation point in a triangle), precedes a general CAUTION or WARNING statement.

The electrical hazard symbol,  (a lightning bolt in a triangle), precedes an electric shock hazard CAUTION or WARNING safety statement.

Technical Assistance

If you encounter a problem with this product, review your configuration information to verify that your selections are consistent with your application: inputs, outputs, alarms, limits, etc. If the problem persists, you can get technical assistance from your local Watlow representative (see back cover), by e-mailing your questions to wintechsupport@watlow.com or by dialing +1 (507) 494-5656 between 7 a.m. and 5 p.m., Central Standard Time (CST). Ask for an Applications Engineer. Please have the following information available when calling:

- Complete model number
- All controller configuration information
- User's Manual
- Wiring diagram.

Warranty

This product is warranted free from defects in material and workmanship for 36 months after delivery to the first purchaser for use, providing that the units have not been misapplied. Since Watlow has no control over their use, and sometimes misuse, we cannot guarantee against failure. Watlow's obligations hereunder, at Watlow's option, are limited to replacement, repair or refund of purchase price, and parts that upon examination prove to be defective within the warranty period specified. This warranty does not apply to damage resulting from transportation, alteration, misuse or abuse.

Return Material Authorization (RMA)

1. Call Watlow Customer Service, +1 (507) 454-5300, for a Return Material Authorization (RMA) number before returning any item for repair. We need this information:
 - Ship to address
 - Bill to address
 - Contact name
 - Phone number
 - Method of return shipment
 - Your P.O. number
 - Detailed description of the problem
 - Any special instructions
 - Name and phone number of person returning the product.
2. Prior approval and an RMA number, from the Customer Service Department, is needed when returning any unused product for credit. Make sure the RMA number is on the outside of the carton, and on all paperwork returned. Ship on a Freight Prepaid basis.
3. After we receive your return, we will examine the unit and try to verify the reason for the return.
4. In cases of manufacturing defect, we will enter a repair order, replacement order or issue credit for material returned.
5. To return products that are not defective, goods must be in new condition, in the original boxes and they must be returned within 120 days of receipt. A 20-percent restocking charge is applied for all returned stock controls and accessories.
6. If the unit cannot be repaired, it will be returned to you with a letter of explanation.
7. Watlow reserves the right to charge for no trouble found (NTF) returns.

The Control Console User's Manual is copyrighted by Watlow Winona, Inc., copyright March 2004 with all rights reserved.

T

Control Console: Table of Contents

Chapter 1: Product Overview

Features and Benefits	.2
Control Console Architecture	.2
Power Requirements	.2
Sensor Input	.2
Heater Output	.3
Communications	.3
Console Elements	.3

Chapter 2: Installation & Wiring

Pre-Installation	.4
Installation	.4

Appendix

Specifications	.6
Controllers	.6
Output Power Switching	.6
Power Requirements	.6
Sensor Input	.6
Operating Environment	.6
Dimensions of Enclosure	.6
Accessory Parts	.7
Ordering Information	.8
How to Reach Us	.10

List of Figures

Figure 1 — Thermal system using a Control Console with a limit	.3
Figure 2 — Rear view of console without the communications option	.4
Figure 3 — Control Console without a limit	.5

Chapter One: Product Overview

Features and Benefits

- Fits easily into confined areas
- Easily transported
- Prewired output
- AMP Mate-'n'-Lok® or twist-and-lock output connector option on most configurations
- Miniature thermocouple connector
- Option of 1/32 or 1/16 DIN Series SD or Series 96 controllers.
- A 1/16 DIN size controller is not available in the mini console.
- On-off rocker switch
- No external components required
- Quick installation and fast start up.

(Mate-'n'-lok® is a registered trademark of AMP Company.)

The Watlow Control Console offers a complete control solution consisting of the temperature control(s), thermocouple input(s), power-switching device(s) and heater output(s), in a small package. Installation is quick and easy; as few as three simple connections and the console is ready for use in your application. Each unit is supplied with a line cord, heater output connector mates, thermocouple connector mates and an on-off rocker switch. A solid-state relay is utilized for fast, reliable switching of the load. The white, powder-coated enclosure has vent openings on the top and bottom for internal heat dissipation.

Control Console Architecture

This product comes in one, two or four zone configurations. The power cord, your choice of heater output connector(s), the thermocouple input connector(s) and communications connector (if applicable) are mounted in the rear of the enclosure. All remaining components are inside the enclosure.

The console comes with 1/16 or 1/32 DIN Series SD or Series 96 controller(s). A solid-state relay serves as the output power-switching device and is powered through the line cord.

Power Requirements

MINI, SNGL and Light Duty DUAL Control Consoles are fused at 10 amps total, 8 amp maximum total load is recommended. The 120V Consoles have a NEMA 5-15 plug. The 208/240V Consoles have a NEMA 6-15 plug.

Heavy Duty DUAL Control Consoles are fused at 20 amps total. A 16 amp maximum total load is recommended. Each zone is individually fused at 10 amps with 8 amps maximum load recommended.

The Heavy Duty DUAL contains a NEMA 5-20 plug. Heavy Duty Controller/Limit Consoles are fused at 15 amps with 12 amps maximum load recommended.

Light Duty Controller/Limit Consoles are fused at 10 amps with 8 amps maximum load recommended.

QUAD consoles are fused at 20 amps total with 16 amps maximum load recommended. Each zone is individually fused at 5 amps with 4 amps maximum load recommended.

All models are available with 120V~ (ac) +10%/-15% MINI, SNGL and Light Duty DUAL Consoles are available with 208/240V~ (ac) +10%.

Sensor Input

The Consoles are ordered with a factory selectable thermocouple (J, K or T) or 2-wire RTD.

The RTD option for the Series SD is only available with a 100-ohm, platinum DIN curve.

The Series 96 has the option of JIS curve, which can be selected by the user. Mating connectors are provided with the sensor input(s).

Heater Output

The Consoles are ordered with a factory selectable choice of AMP Mate-'n'-Lok® connector(s) or twist and lock connector(s) for heater output(s). Mating connector(s) are provided for the heater output(s).

Communications

EIA-232 Communications available on SNGL with a Series 96 controller. EIA-485 Communications are available on two and four zone Consoles. No mating connector is provided for communications.

Console Elements

The Control Console contains the following elements of the thermal system:

1. communications port for data acquisition included with consoles containing communications (optional);
2. temperature controlling device;
3. heater output;
4. sensor input;
5. power switching device;
6. limit for consoles with controller/limit (optional).

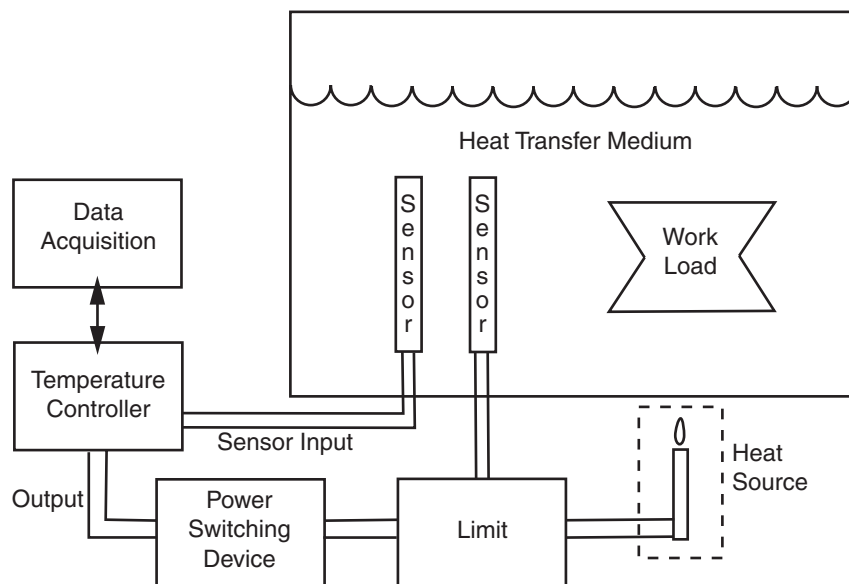

Figure 1 — Thermal system using a Control Console with a limit.

Chapter Two: Installation & Wiring

Pre-Installation

⚠ CAUTION

High Temperature Limit: Only the Watlow Controller/Limit console utilizes a high temperature limit control. Install high temperature control protection in systems where an overtemperature fault condition would present a fire hazard or other hazard. Failure to install temperature control protection where a potential hazard exists could result in damage to equipment and property, and injury to personnel.

⚠ WARNING

Fire Hazard: Extreme care should be taken to locate the control console in a safe environment. Mounting the control console in atmospheres containing combustible gasses and vapors should be avoided. According to Article 501 of the National Electrical Code (NEC), the maximum surface temperature of the enclosure shall not exceed 80% of the auto-ignition of the surrounding atmosphere when the control console is continuously energized. Care should be taken to keep combustible materials far enough away to be free of the effects of high temperatures.

⚠ WARNING

Heater Output. Power is applied to the heater output terminals via the line cord. L1 is switched through the solid-state relay to the connector and L2 is connected to the heater output connector. **DO NOT** apply voltage to the heater.

Installation

1. Wiring Connections

Wiring of the control consoles utilizes connections for the thermocouple, input power and heater output. The mating connectors are shipped with the consoles. It is the user's responsibility to properly size and install feeder wire.

Refer to Figure 2 for 120V layout. Refer to Figure 3 for wiring diagram.



Figure 2 — Rear view of console without the communications option.

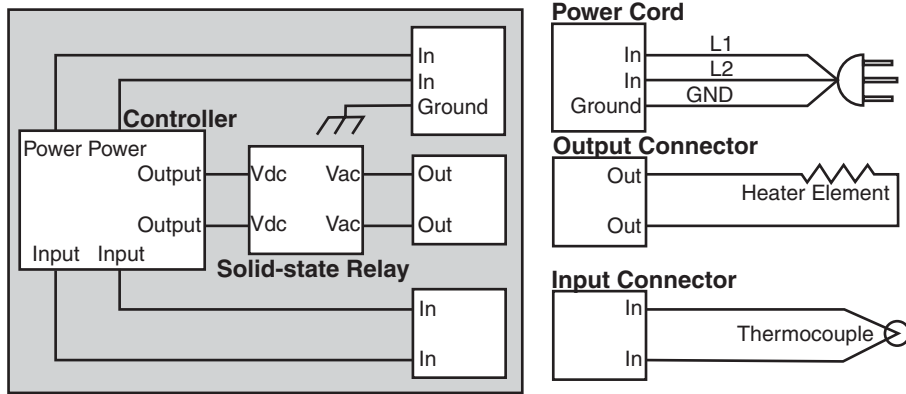

Figure 3 — Control Console without a limit.

2. Heater Connections

The heater output(s) utilizes either AMP Mate-'n'-Lok® connector(s) or twist-and-lock connector(s). The mating connector and terminals are provided.

To ensure proper crimping of the AMP Mate-'n'-Lok® terminals, the proper equipment should be used. AMP recommends using part number 90300-2 for terminal crimping and part number 458994-2 for extraction of the terminals from the connector. Please consult the TYCO-AMP Corporation at 1-800-468-2023 for further information.

3. Thermocouple Connections

Using a small screwdriver, remove the two screws holding the cover of the male miniature thermocouple connector(s). Loosen, but do not remove the + and - terminal screws. The connector(s) can accommodate wire sizes up to 20-gauge, stranded wire. Insert the red wire from the thermocouple to the (-) terminal of the connector(s). Do not wrap the wire around the terminal. Repeat the step for the positive thermocouple lead.

4. Communication Connections

EIA-232 Communications

- Female DB9 connector mounted in box
- Pin 2: receive
- Pin 3: transmit
- Pin 5: common

EIA-485 Communications

- Female DB9 connector mounted in box
- Pin 2: T-/R-(A)
- Pin 3: T+/R+(B)
- Pin 5: common

* To ensure proper crimping of the DB9 terminal, the proper equipment should be used. AMP recommends using part number 58448-2.

5. Start Up

For start up and function of the temperature controller, please refer to the user's manual for the respective temperature controller that is included with the Console.

Appendix

Specifications

Controllers

- Watlow Series 96 (Refer to *Series 96 User's Manual* for controller specifications.)
- Watlow Series SD (1/16 or 1/32 DIN), (Refer to *Series SD User's Manual* for controller/limit specifications.)
- Watlow Series 97 (Refer to *Series 97 User's Manual* for controller/limit specifications.)

Power Requirements and Output Power Switching

- Utilizes solid-state relay.
- Output is powered through the line cord.
- MINI, SNGL, and Light Duty DUAL Control Consoles are fused at 10 amps total, 8 amp maximum total load is recommended.
- 120V have NEMA 5-15 plug
- 208/240V have NEMA 6-15 plug
- Heavy Duty DUAL Control Consoles are fused at 20 amps total, 16 amp maximum total load is recommended. Each zone is individually fused at 10 amps with 8 amps maximum load recommended.
- NEMA 5-20 plug
- Heavy Duty Controller/Limit Consoles are fused at 15 amps with 12 amps maximum load recommended.
- Light Duty Controller/Limit Consoles are fused at 10 amps with 8 amps maximum load recommended.
- QUAD consoles are fused at 20 amps total with 16 amps maximum load recommended. Each zone is individually fused at 5 amps with 4 amps maximum load recommended.
- All models are available with 120V~ +10%/-15%.
- MINI, SNGL and Light Duty DUAL consoles are available with 208/240V~ +10%.
- 208/240V fused for domestic use only (both lines fused).

Sensor Input

- Factory selectable thermocouple (J, K or T) or 2-wire RTD.
- RTD for Series SD series only available as 100-ohm, platinum DIN curve.
- Series 96 has option of DIN or JIS curve, which can be selected by user.
- Choice of AMP Mate-'n'-Lok® connector(s) or twist-and-lock connector(s) for heater output(s).
- Mating connector(s) provided.
- EIA-232 communications available in SNGL control consoles with a Series 96 controller.
- EIA-485 communications are available in DUAL and QUAD Control Consoles with a Series 96 controller.
- EIA-485 to EIA-232 communications converters and power supplies are available from Watlow.

Operating Environment

- 0 to 45°C (32 to 113°F)
- 0 to 90% RH, noncondensing

Dimensions of Enclosure

Console	Height	Width	Depth
Mini	76 mm	90 mm	180 mm
	3.0 in	3.5 in	7.1 in
Single	119 mm	76 mm	191 mm
	4.7 in	3.0 in	7.5 in
Dual	121 mm	152 mm	187 mm
	4.75 in	6.0 in	7.375 in (SD)
Quad	114 mm	305 mm	191 mm
	4.5 in	12.0 in	7.5 in

Accessory Parts

Manufacturer	Description	Manufacturer's Part Number	Relationship to Console
Tyco-Amp	Mate-n-Lok® Plug	1-480698-0	Ship with
Tyco-Amp	Mate-n-Lok® Plug	350550-1	Ship with
Hubbell	Plug	7465V	Ship with 120V units
Hubbell	Plug	7485	Ship with 208/240V units
Tyco-Amp	DB9 (male)	205204-1	Ship with
Tyco-Amp	DB9 (pins)	1-66506-0	Ship with
B & B Electronics	MRS 232-485 Converter	485SD9TB	Watlow part number 0830-0473-0001
B & B Electronics	MRS 232-485 Converter	485PS2	Watlow part number 0830-0473-0002

Mate-'n'-lok® is a registered trademark of AMP Company.

Ordering Information

To order, complete the model number using the information below.

Control Console: Mini

Single zone
Self-contained unit

MINI - _____ **- 0 0 0 0**

Input _____

J Type J thermocouple
K Type K thermocouple
T Type T thermocouple
R RTD (100 ohm, 2-wire)

Controllers _____

G Series SD (1/32 DIN) w EIA-485 comms
5 Series SD (1/32 DIN)

Display Color _____

R Red/Green

Line Voltage _____

1 120V~ (ac)
2 208/240V~ (ac)

Control Console: Dual

Two zones
Self-contained unit

DUAL - _____ **-** _____ **0 0**

Controllers _____

A Series 96 w ramp and soak
B Series 96/97 w ramp and soak
E Series 96 w EIA-485 comms
F Series SD (1/16 DIN) w EIA-485 comms
G Series SD (1/32 DIN) w EIA-485 comms
4 Series 96
5 Series SD (1/32 DIN)
7 Series SD (1/16DIN)
8 Series 96/97 Controller/Limit *
9 Series SD6C/SD6L Controller/Limit *
0 Series SD6C/SD3L Controller/Limit *

Input _____

J Type J thermocouple
K Type K thermocouple
T Type T thermocouple
R RTD (2-wire)

Display Series 96/97/SD _____

RG Red/Green (only option on Series SD 1/32 DIN)
RR Red/Red
GG Green/Green (only available on Series 96 & 97)
GR Green/Red (only available on Series 96 & 97)

Output Connector _____

1 Amp Mate-'n'-Lok®
2 Twist and lock

Line Voltage _____

1 120V~ (ac) (light duty: 4 A per zone; 8 A total)
2 208/240V~ (ac) (light duty: 4 A per zone; 8 A total)
3 120V~ (ac) (heavy duty: 8 A per zone; 16 A total)

*Control Limit

Light Duty: 8 A total
Heavy Duty: 12 A total

Control Console: SNGL

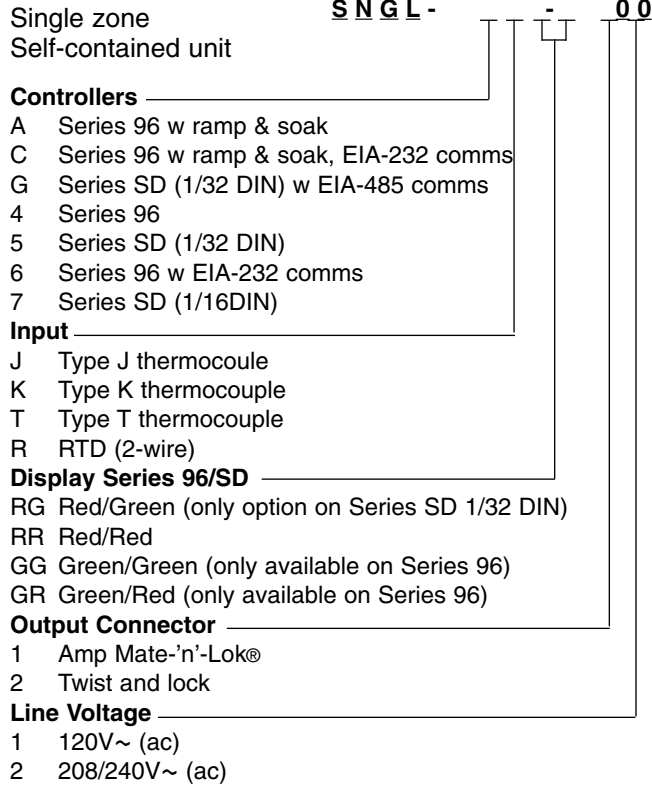

Control Console: Quad

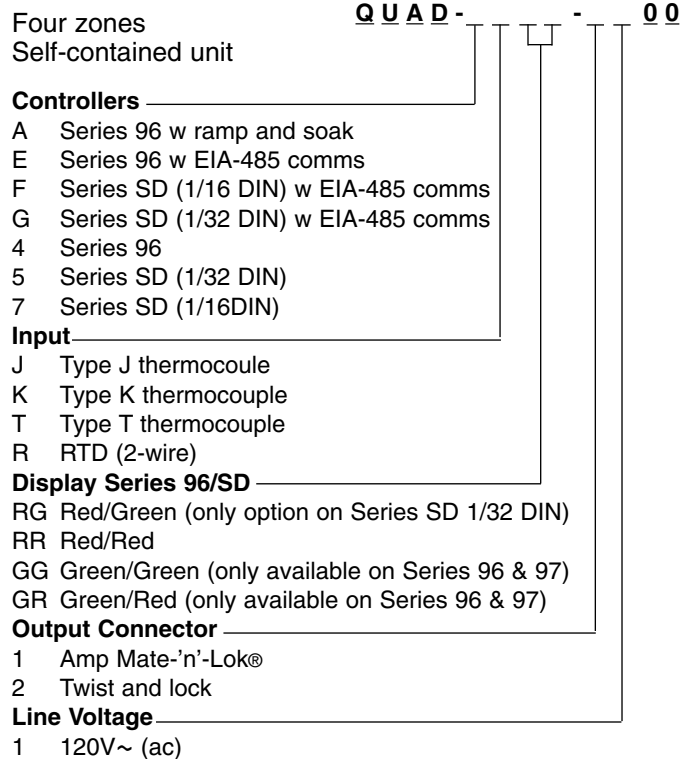

How to Reach Us



Your Authorized Watlow Distributor:

United States (headquarters):

Watlow Electric Manufacturing Company
12001 Lackland Road
St. Louis, Missouri USA 63146
Telephone: +1 (314) 878-4600
Fax: +1 (314) 878-6814

Europe:

Watlow GmbH
Industriegebiet Heidig
Lauchwasenstr. 1, Postfach 1165,
Kronau 76709 Germany
Telephone: +49 7253-9400 0
Fax: +49 7253-9400 44

Watlow France S.A.R.L.
Immeuble Somag, 16 Rue Ampère,
Cergy Pontoise CEDEX 95307 France
Telephone: +33 (1) 3073-2425
Fax: +33 (1) 3073-2875

Watlow Italy S.R.L.
Via Meucci 14
20094 Corsico MI
Italy
Telephone: +39 (02) 4588841
Fax: +39 (02) 458-69954

Watlow Limited
Robey Close, Linby Industrial Estate,
Linby Nottingham England, NG15 8AA
Telephone: +44 (0) 115 9640777
Fax: +44 (0) 115 9640071

Latin America:

Watlow de México
Av. Fundición #5,
Col. Parques Industriales,
Querétaro, Qro. México CP-76130
Telephone: +52 (442) 217-6235
Fax: +52 (442) 217-6403

Asia/Pacific:

Watlow Australia Pty., Ltd.
23 Gladstone Park Drive,
Tullamarine, Victoria 3043 Australia
Telephone: +61 (39) 335-6449
Fax: +61 (39) 330-3566

Watlow China, Inc.
179, Zhong Shan Xi Road
Hong Qiao Cointek Bldg, Fl. 4, Unit P
Shanghai 200051 China
Telephone: +86 (21) 6229-8917
Fax: +86 (21) 6228-4654

Watlow Japan Ltd. K.K.
Azabu Embassy Heights 106,
1-11-12 Akasaka,
Minato-ku, Tokyo 107-0052 Japan
Telephone: +81 (03) 5403-4688
Fax: +81 (03) 5403-4646

Watlow Korea Co., Ltd.
Hanil Bldg., 3rd Floor
210-5 Yangje-Dong Seocho-Gu
Seoul, 137-130 Korea
Telephone: +82 (2) 575-9804
Fax: +82 (2) 575-9831

Watlow Malaysia Sdn Bhd
38B Jalan Tun Dr Awang
11900 Bayan Lepas
Penang Malaysia
Telephone: +60 (4) 641-5977
Fax: +60 (4) 641-5979

Watlow Singapore Pte. Ltd.
Ayer Rajah Crescent
#03-23 Ayer Rajah Industrial Estate
Singapore 139949
Telephone: +65 773 9488
Fax: +65 778 0323

Watlow Electric Taiwan
10F-1 No. 189
Chi-Shen 2nd Road,
Kaohsiung, Taiwan
Telephone: +886 (7) 288-5168
Fax: +886 (7) 288-5568