

Operating Instructions

Memosens CLS16E

Conductivity sensor with Memosens protocol
For conductive measurement of conductivity in liquids







Table of contents







| | | | | | |
|----------|---|-----------|--------------------|-----------------------------------|-----------|
| 1 | About this document | 3 | 10 | Technical data | 14 |
| 1.1 | Warnings | 3 | 10.1 | Input | 14 |
| 1.2 | Symbols | 3 | 10.2 | Performance characteristics | 14 |
| 1.3 | Documentation | 3 | 10.3 | Environment | 15 |
| 2 | Basic safety instructions | 4 | 10.4 | Process | 15 |
| 2.1 | Requirements for the personnel | 4 | 10.5 | Mechanical construction | 16 |
| 2.2 | Intended use | 4 | | | |
| 2.3 | Workplace safety | 4 | Index | | 17 |
| 2.4 | Operational safety | 4 | | | |
| 2.5 | Product safety | 5 | | | |
| 3 | Incoming acceptance and product identification | 5 | | | |
| 3.1 | Incoming acceptance | 5 | | | |
| 3.2 | Product identification | 5 | | | |
| 3.3 | Scope of delivery | 6 | | | |
| 4 | Mounting | 6 | | | |
| 4.1 | Mounting requirements | 6 | | | |
| 4.2 | Mounting the sensor | 7 | | | |
| 4.3 | Post-mounting check | 7 | | | |
| 5 | Electrical connection | 8 | | | |
| 5.1 | Connecting the sensor | 8 | | | |
| 5.2 | Ensuring the degree of protection | 8 | | | |
| 5.3 | Post-connection check | 8 | | | |
| 6 | Commissioning | 9 | | | |
| 7 | Maintenance | 9 | | | |
| 8 | Repair | 10 | | | |
| 8.1 | General notes | 10 | | | |
| 8.2 | Spare parts | 11 | | | |
| 8.3 | Endress+Hauser services | 11 | | | |
| 8.4 | Return | 11 | | | |
| 8.5 | Disposal | 12 | | | |
| 9 | Accessories | 13 | | | |
| 9.1 | Measuring cable | 13 | | | |
| 9.2 | Sensor regeneration | 13 | | | |
| 9.3 | Calibration solutions | 13 | | | |
| 9.4 | Calibration set | 13 | | | |

1 About this document

1.1 Warnings

| Structure of information | Meaning |
|---|--|
| <p> DANGER</p> <p>Causes (/consequences) If necessary, Consequences of non-compliance (if applicable) ► Corrective action</p> | <p>This symbol alerts you to a dangerous situation. Failure to avoid the dangerous situation will result in a fatal or serious injury.</p> |
| <p> WARNING</p> <p>Causes (/consequences) If necessary, Consequences of non-compliance (if applicable) ► Corrective action</p> | <p>This symbol alerts you to a dangerous situation. Failure to avoid the dangerous situation can result in a fatal or serious injury.</p> |
| <p> CAUTION</p> <p>Causes (/consequences) If necessary, Consequences of non-compliance (if applicable) ► Corrective action</p> | <p>This symbol alerts you to a dangerous situation. Failure to avoid this situation can result in minor or more serious injuries.</p> |
| <p> NOTICE</p> <p>Cause/situation If necessary, Consequences of non-compliance (if applicable) ► Action/note</p> | <p>This symbol alerts you to situations which may result in damage to property.</p> |

1.2 Symbols

-  Additional information, tips
-  Permitted or recommended
-  Not permitted or not recommended
-  Reference to device documentation
-  Reference to page
-  Reference to graphic
-  Result of a step

1.3 Documentation

 Technical Information Memosens CLS16E, TI01527C

 Special Documentation for hygienic applications, SD02751C

In addition to these Operating Instructions, an XA with "Safety instructions for electrical apparatus in the hazardous area" is also included with sensors for use in the hazardous area.

- Please follow instructions on use in the hazardous area carefully.

2 Basic safety instructions

2.1 Requirements for the personnel

- Installation, commissioning, operation and maintenance of the measuring system may be carried out only by specially trained technical personnel.
- The technical personnel must be authorized by the plant operator to carry out the specified activities.
- The electrical connection may be performed only by an electrical technician.
- The technical personnel must have read and understood these Operating Instructions and must follow the instructions contained therein.
- Faults at the measuring point may only be rectified by authorized and specially trained personnel.

 Repairs not described in the Operating Instructions provided must be carried out only directly at the manufacturer's site or by the service organization.

2.2 Intended use

The conductivity sensor is designed for the conductive measurement of the conductivity of liquids.

It is used in the following areas:

Measurements in pure and ultrapure water with hygienic requirements

Use of the device for any purpose other than that described, poses a threat to the safety of people and of the entire measuring system and is therefore not permitted.

The manufacturer is not liable for damage caused by improper or non-designated use.

2.3 Workplace safety

As the user, you are responsible for complying with the following safety conditions:

- Installation guidelines
- Local standards and regulations
- Regulations for explosion protection

Electromagnetic compatibility

- The product has been tested for electromagnetic compatibility in accordance with the applicable international standards for industrial applications.
- The electromagnetic compatibility indicated applies only to a product that has been connected in accordance with these Operating Instructions.

2.4 Operational safety

Before commissioning the entire measuring point:

1. Verify that all connections are correct.
2. Ensure that electrical cables and hose connections are undamaged.
3. Do not operate damaged products, and protect them against unintentional operation.
4. Label damaged products as defective.

During operation:

- ▶ If faults cannot be rectified:
products must be taken out of service and protected against unintentional operation.

2.5 Product safety

The product is designed to meet state-of-the-art safety requirements, has been tested, and left the factory in a condition in which it is safe to operate. The relevant regulations and international standards have been observed.

3 Incoming acceptance and product identification

3.1 Incoming acceptance

1. Verify that the packaging is undamaged.
 - ↳ Notify the supplier of any damage to the packaging.
Keep the damaged packaging until the issue has been resolved.
2. Verify that the contents are undamaged.
 - ↳ Notify the supplier of any damage to the delivery contents.
Keep the damaged goods until the issue has been resolved.
3. Check that the delivery is complete and nothing is missing.
 - ↳ Compare the shipping documents with your order.
4. Pack the product for storage and transportation in such a way that it is protected against impact and moisture.
 - ↳ The original packaging offers the best protection.
Make sure to comply with the permitted ambient conditions.

If you have any questions, please contact your supplier or your local Sales Center.

3.2 Product identification

3.2.1 Nameplate

The nameplate provides you with the following information on your device:

- Manufacturer identification
 - Extended order code
 - Serial number
 - Safety information and warnings
- ▶ Compare the information on the nameplate with the order.

3.2.2 Product identification

Product page

www.endress.com/cls16e

Interpreting the order code

The order code and serial number of your product can be found in the following locations:

- On the nameplate
- In the delivery papers

Obtaining information on the product

1. Open www.endress.com.
2. Call up the site search (magnifying glass).
3. Enter a valid serial number.
4. Search.
 - ↳ The product structure is displayed in a popup window.
5. Click on the product image in the popup window.
 - ↳ A new window (**Device Viewer**) opens. All of the information relating to your device is displayed in this window as well as the product documentation.

Manufacturer address

Endress+Hauser Conducta GmbH+Co. KG
Dieselstraße 24
D-70839 Gerlingen

3.3 Scope of delivery

The scope of delivery includes:

- Sensor in the version ordered
- Operating Instructions

4 Mounting

4.1 Mounting requirements

4.1.1 General installation instructions

The sensors are installed directly via the process connection.

- ▶ If using the sensor in the ultrapure water range, you must work under air-evacuated conditions.
 - ↳ Otherwise, the CO₂ in the air can dissolve in the water and its (weak) dissociation can increase the conductivity by up to 3 µS/cm.

4.1.2 Hygiene-compliant installation

- ▶ Easily cleanable installation of equipment according to the criteria of the EHEDG must be free of dead legs.
- ▶ If a dead leg is unavoidable, it shall be kept as short as possible. Under no circumstances shall the length of a dead leg L exceed the pipe's inner diameter D minus the equipment's enveloping diameter d . The condition $L \leq D - d$ applies.
- ▶ Furthermore, the dead leg must be self-draining, so neither product nor process fluids are retained therein.
- ▶ Within tank installations, the cleaning device must be located so that it directly flushes the dead leg.
- ▶ For further reference, see the recommendations concerning hygienic seals and installations in EHEDG Doc. 10 and the Position Paper: "Easy cleanable Pipe couplings and Process connections".

For 3-A-compliant installation, please observe the following:

- ▶ After the device has been mounted, hygienic integrity must be guaranteed.
- ▶ 3-A-compliant process connections must be used.

4.2 Mounting the sensor

1. Install the sensor via the process connection or an assembly.
- 2.

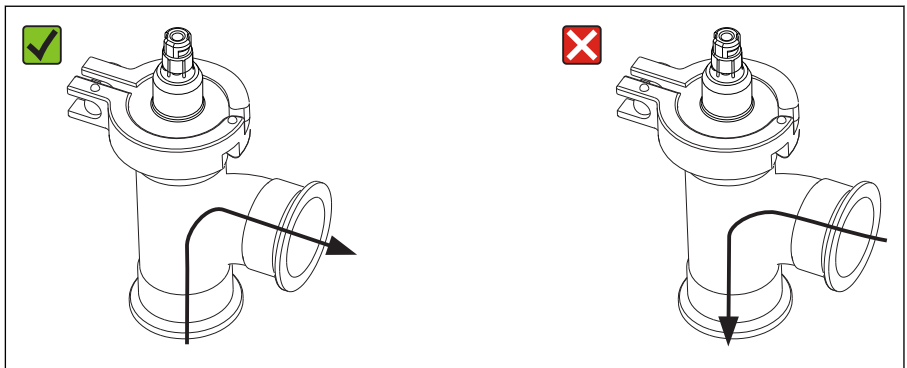

A0042910

When installing in pipes:

Pay attention to the flow direction.

3. Ensure that the electrodes are fully immersed in the medium during measurement. Immersion depth: at least 35 mm (1.38").

4.3 Post-mounting check

1. Are the sensor and cable undamaged?
2. Is the sensor installed in the process connection and is not suspended from the cable?

5 Electrical connection

⚠ WARNING

Device is live!

Incorrect connection may result in injury or death!

- ▶ The electrical connection may be performed only by an electrical technician.
- ▶ The electrical technician must have read and understood these Operating Instructions and must follow the instructions contained therein.
- ▶ **Prior** to commencing connection work, ensure that no voltage is present on any cable.

5.1 Connecting the sensor

The electrical connection of the sensor to the transmitter is established using the measuring cable CYK10.

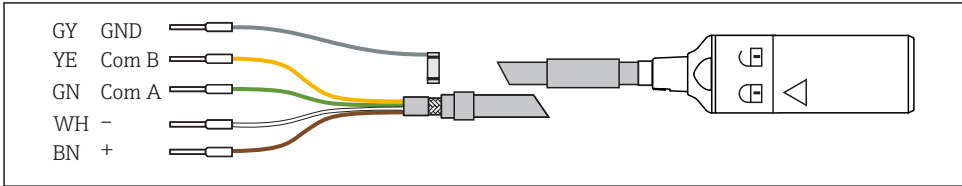

1 *Measuring cable CYK10*

5.2 Ensuring the degree of protection

Only the mechanical and electrical connections which are described in these instructions and which are necessary for the required, designated use, may be carried out on the device delivered.

- ▶ Exercise care when carrying out the work.

Otherwise, the individual types of protection (Ingress Protection (IP), electrical safety, EMC interference immunity) agreed for this product can no longer be guaranteed due, for example to covers being left off or cable (ends) that are loose or insufficiently secured.

5.3 Post-connection check

⚠ WARNING

Connection errors

The safety of people and of the measuring point is at risk! The manufacturer does not accept any responsibility for errors that result from failure to comply with the instructions in this manual.

- ▶ Put the measuring point into operation only if you can answer **yes** to **all** the following questions.

Product status and specifications

- ▶ Are the sensor and cable free from damage on the outside?

Electrical connection

- ▶ Is the installed cable strain-relieved and not twisted?
- ▶ Is a sufficient length of the cable cores stripped, and are the cores correctly positioned in the terminal on the transmitter?
- ▶ Are all plug-in terminals on the transmitter securely engaged?
- ▶ Are all cable entries mounted on the transmitter, tightened and leak-tight?

6 Commissioning

Prior to initial commissioning, ensure that:

- The sensor is correctly installed
- The electrical connection is correct

1. Check the temperature compensation and damping settings on the transmitter.



Operating Instructions of the transmitter being used, e.g. BA01245C if using Liquiline CM44x or CM44xR.

⚠ WARNING

Escaping process medium

Risk of injury from high pressure, high temperatures or chemical hazards!

- ▶ Before applying pressure to an assembly with cleaning system, ensure that the system has been connected correctly.
- ▶ If you cannot reliably establish the correct connection, do not install the assembly in the process.

If using an assembly with automatic cleaning function:

2. Check that the cleaning medium (water or air, for example) is connected correctly.
3. Following commissioning:
Maintain the sensor at regular intervals.
 - ↳ This is the only way to ensure reliable measurements.

7 Maintenance

⚠ CAUTION

Corrosive chemicals

Risk of chemical burns to the eyes and skin and risk of damage to clothing and equipment!

- ▶ It is absolutely essential to protect the eyes and hands properly when working with acids, alkalis and organic solvents!
- ▶ Wear protective goggles and safety gloves.
- ▶ Clean away splashes on clothes and other objects to prevent any damage.
- ▶ Comply with instructions in the safety data sheets for the chemicals used.

⚠ WARNING**Thiocarbamide**

Harmful if swallowed! Limited evidence of carcinogenicity! Possible risk of harm to the unborn child! Dangerous for the environment with long-term effects!

- ▶ Wear protective goggles, protective gloves and appropriate protective clothing.
- ▶ Avoid all contact with the eyes, mouth and skin.
- ▶ Avoid discharge into the environment.

Clean away fouling on the sensor as follows depending on the type of fouling:

1. Oily and greasy films:

Clean with fat solvent, e.g. alcohol, or hot water and agents containing surfactants (alkaline) (e.g. dishwashing detergent).

2. Lime and metal hydroxide buildup and low solubility (lyophobic) organic buildup:

Dissolve buildup with diluted hydrochloric acid (3 %) and then rinse thoroughly with plenty of clear water.

3. Sulfidic buildup (from flue gas desulfurization or wastewater treatment plants):

Use a mixture of hydrochloric acid (3 %) and thiocarbamide (commercially available) and then rinse thoroughly with plenty of clear water.

4. Buildup containing proteins (e.g. food industry):

Use a mixture of hydrochloric acid (0.5 %) and pepsin (commercially available) and then rinse thoroughly with plenty of clear water.

5. Readily soluble biological buildup:

Rinse with pressurized water.

After cleaning, rinse the sensor thoroughly with water.

8 Repair

8.1 General notes

The repair and conversion concept provides for the following:

- The product has a modular design
- Spare parts are grouped into kits which include the associated kit instructions
- Only use original spare parts from the manufacturer
- Repairs are carried out by the manufacturer's Service Department or by trained users
- Certified devices can only be converted to other certified device versions by the manufacturer's Service Department or at the factory
- Observe applicable standards, national regulations, Ex documentation (XA) and certificates

1. Carry out the repair according to the kit instructions.**2.** Document the repair and conversion and enter, or have entered, in the Life Cycle Management tool (W@M).

8.2 Spare parts

Device spare parts that are currently available for delivery can be found on the website:

www.endress.com/device-viewer

- ▶ Quote the serial number of the device when ordering spare parts.

8.3 Endress+Hauser services

Intact seals are a prerequisite for safe and reliable measurements. The seal should be replaced at regular intervals to guarantee maximum sensor operational safety and hygiene.

Practical repair intervals can only be determined by the user as they depend greatly on the operating conditions, such as:

- Type and temperature of the product
- Type and temperature of the cleaning agent
- Number of cleanings
- Number of sterilizations
- Operating environment

Recommended intervals for seal replacement (reference values)

| Application | Window |
|---|--------------------|
| Media with temperatures from 50 to 100 °C (122 to 212 °F) | Approx. 18 months |
| Media with temperatures < 50 °C (122 °F) | Approx. 36 months |
| Sterilization cycles, max. 150 °C (302 °F), 45 min. | Approx. 400 cycles |

To ensure your sensor is operational again after being exposed to very high loads, you can have it regenerated in the factory. In the factory, the sensor is fitted with new seals and recalibrated.

Please contact your sales office for information on replacing the seal and recalibration in the factory.

8.4 Return

The product must be returned if repairs or a factory calibration are required, or if the wrong product was ordered or delivered. As an ISO-certified company and also due to legal regulations, Endress+Hauser is obliged to follow certain procedures when handling any returned products that have been in contact with medium.

To ensure the swift, safe and professional return of the device:

- ▶ Refer to the website www.endress.com/support/return-material for information on the procedure and conditions for returning devices.

8.5 Disposal



If required by the Directive 2012/19/EU on waste electrical and electronic equipment (WEEE), the product is marked with the depicted symbol in order to minimize the disposal of WEEE as unsorted municipal waste. Do not dispose of products bearing this marking as unsorted municipal waste. Instead, return them to Endress+Hauser for disposal under the applicable conditions.

9 Accessories

The following are the most important accessories available at the time this documentation was issued.

- ▶ For accessories not listed here, please contact your Service or Sales Center.

9.1 Measuring cable

Memosens data cable CYK10

- For digital sensors with Memosens technology
- Product Configurator on the product page: www.endress.com/cyk10



Technical Information TI00118C

Memosens data cable CYK11

- Extension cable for digital sensors with Memosens protocol
- Product Configurator on the product page: www.endress.com/cyk11



Technical Information TI00118C

9.2 Sensor regeneration

Replacement of seals and recalibration in the factory

Order No. 51505585

9.3 Calibration solutions

Conductivity calibration solutions CLY11

Precision solutions referenced to SRM (Standard Reference Material) by NIST for qualified calibration of conductivity measuring systems in accordance with ISO 9000

- CLY11-A, 74 $\mu\text{S}/\text{cm}$ (reference temperature 25 °C (77 °F)), 500 ml (16.9 fl.oz)
Order No. 50081902
- CLY11-B, 149.6 $\mu\text{S}/\text{cm}$ (reference temperature 25 °C (77 °F)), 500 ml (16.9 fl.oz)
Order No. 50081903



Technical Information TI00162C

9.4 Calibration set

Conducual CLY421

- Conductivity calibration set (case) for ultrapure water applications
- Complete, factory-calibrated measuring system with certificate, traceable to SRM by NIST and PTB, for comparison measurement in ultrapure water up to max. 20 $\mu\text{S}/\text{cm}$
- Product Configurator on the product page: www.endress.com/cly421



Technical Information TI00496C/07/EN

10 Technical data

10.1 Input

10.1.1 Measured variables

- Conductivity
- Temperature

10.1.2 Measuring ranges

Conductivity¹⁾ 40 nS/cm to 500 µS/cm

1) In relation to water at 25 °C (77 °F)

Temperature -5 to 150 °C (23 to 302 °F)

10.1.3 Cell constant

$k = 0.1 \text{ cm}^{-1}$

10.1.4 Temperature compensation

Pt1000 (Class A according to IEC 60751)

10.2 Performance characteristics

10.2.1 Measuring uncertainty

Each individual sensor is factory-measured in a solution with approx. 5 µS/cm using a reference measuring system traceable to NIST or PTB. The exact cell constant is entered into the manufacturer inspection certificate supplied. The uncertainty of measurement in determining the cell constant is 1.0 %.

10.2.2 Response time

Conductivity $t_{95} \leq 2 \text{ s}$

Temperature¹⁾ $t_{90} \leq 9 \text{ s}$

1) DIN VDI/VDE 3522-2 (0.3 m/s laminar)

10.2.3 Maximum measured error

Conductivity $\leq 2 \%$ of reading, in specified measuring range

Temperature $\leq 0.5 \text{ K}$, in measuring range -5 to 120 °C (23 to 248 °F)

$\leq 1.0 \text{ K}$, in measuring range 120 to 150 °C (248 to 302 °F)

10.2.4 Repeatability

| | |
|--------------|--|
| Conductivity | ≤ 0.2 % of reading, in specified measuring range |
| Temperature | ≤ 0.05 K |

10.3 Environment

10.3.1 Ambient temperature

-20 to 60 °C (-4 to 140 °F)

10.3.2 Storage temperature

-25 to +80 °C (-10 to +180 °F)

10.3.3 Degree of protection

IP 68 / NEMA type 6P (1.9 m water column, 20 °C, 24 h)

10.4 Process

10.4.1 Process temperature

| | |
|-----------------------------|---|
| Normal operation | -5 to 120 °C (23 to 248 °F) |
| Sterilization (max. 45 min) | Max. 150 °C (302 °F) at 6 bar (87 psi) absolute |

10.4.2 Process pressure

13 bar (188 psi) absolute, at 20 °C (68 °F)
9 bar (130 psi) absolute, at 120 °C (248 °F)
0.1 bar (1.5 psi) absolute (negative pressure), at 20 °C (68 °F)

10.4.3 Temperature/pressure ratings

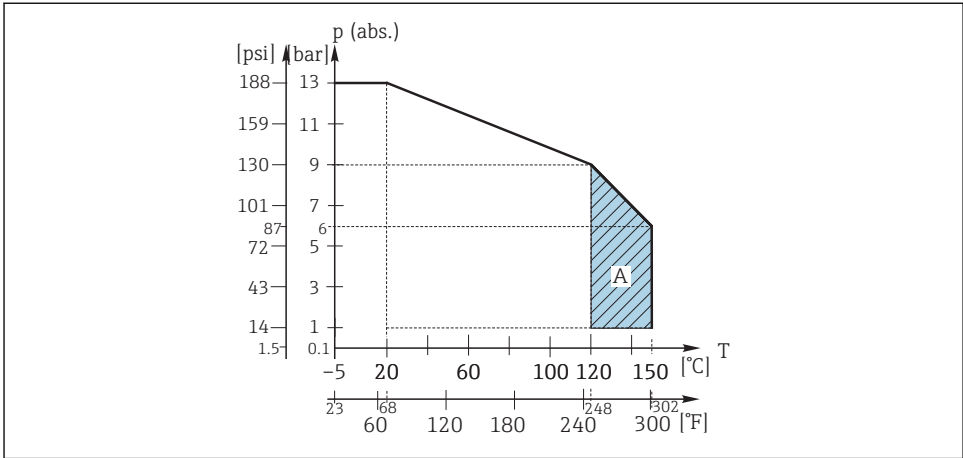

A0044756

2 Mechanical pressure-temperature resistance

A Can be sterilized for a short time (45 min.)

10.5 Mechanical construction

10.5.1 Weight

Approx. 0.13 to 0.75 kg (0.29 to 1.65 lbs) depending on version

10.5.2 Materials (in contact with medium)

| | |
|------------|---|
| Electrodes | Electropolished, stainless steel 1.4435 (AISI 316L) |
| Seal | Gasket seal ISOLAST (FFKM) |

10.5.3 Process connection

1½", 2" as per ISO 2852 (also suitable for TRI-CLAMP, DIN 32676)
 Tuchenhagen VARIVENT N DN 50 to 125, DN40 to 125
 NEUMO BioControl D50

10.5.4 Surface roughness

$R_a \leq 0.38 \mu\text{m}$, electropolished

Index

A

Ambient temperature 15

C

Cell constant 14

Check

 Connection 8

 Mounting 7

Connection

 Check 8

 Ensuring the degree of protection 8

D

Degree of protection

 Ensuring 8

 Technical data 15

Disposal 12

Documentation 3

E

Electrical connection 8

Environment 15

I

Incoming acceptance 5

Intended use 4

M

Materials 16

Maximum measured error 14

Measured variables 14

Measuring ranges 14

Measuring uncertainty 14

Mounting

 Check 7

 Sensor 7

N

Nameplate 5

O

Operational safety 4

P

Performance characteristics 14

Pressure/temperature ratings 16

Process 15

Process connection 16

Process pressure 15

Process temperature 15

Product identification 6

Product safety 5

R

Recalibration 11

Regeneration 11

Repair 10

Repeatability 15

Replacing the seal 11

Response time 14

Return 11

S

Safety

 Operation 4

 Product 5

 Workplace safety 4

Safety instructions 4

Scope of delivery 6

Sensor

 Cleaning 9

 Connecting 8

 Mounting 7

Spare parts 11

Storage temperature 15

Surface roughness 16

Symbols 3

T

Technical data

 Environment 15

 Input 14

 Mechanical construction 16

 Performance characteristics 14

 Process 15

Temperature compensation 14

Temperature/pressure ratings 16

U

Use 4

W

Warnings 3
Weight 16
Workplace safety 4



71545053

www.addresses.endress.com
