

User's Guide

EXTECH[®]
INSTRUMENTS
A FLIR COMPANY

Energy Logger

Model EM100

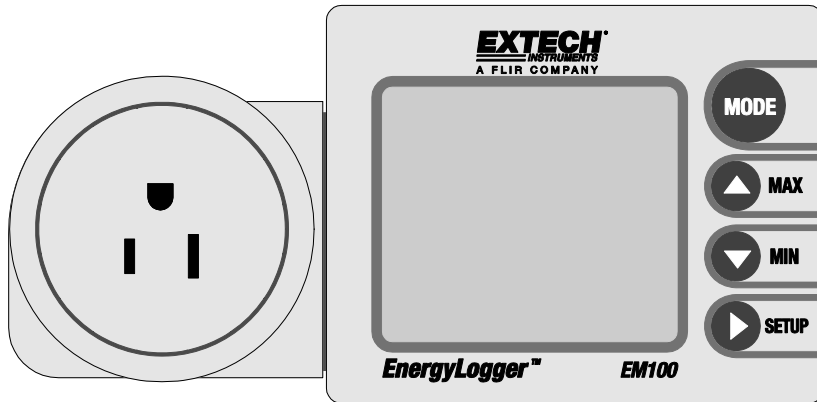

Introduction

Congratulations on your purchase of the Extech EM100 Energy Logger. The EM100 monitors and displays the cost of powering loads such as household appliances, power tools, industrial machinery, and many other types of electrical and electronic equipment. The EM100 Energy Logger has been EMV-tested for safety and corresponds with the requirements of valid European and national guidelines.

In order to maintain the integrity of this instrument and to ensure safe operation, please read and follow the instructions in this operating manual. This instrument is shipped fully tested and calibrated and, with proper use, will provide years of reliable service.

Proper Use

The measurement range of the EM100 Energy Logger is 1.5W to 1400W. Measurements outside this range should be considered unreliable; if the instrument is over-loaded, instrument damage may result.

The EM100 Energy Logger can monitor and measure electrical loads. Although the EM100 Energy Logger is very accurate, it is not officially certified for usage by power companies and users for measuring power expenditures.

- The EM100 Energy Logger is certified for 120V AC 50/60 Hz operation only
- Only power loads with a power supply of 120V AC 50/60 Hz may be connected
- The maximum power of any connected load may not exceed 1400W (max. current 12A)
- Operation of the EM100 Energy Logger is permitted in dry, interior spaces only. This device must not be used outdoors
- Always observe the declarations on the identification labels of connected power loads

Uses other than the ones described in this manual may lead to product damage and are associated with hazards such as short circuits, fire, electric shock, etc. The instrument must not be converted or modified in any way. Strictly observe the safety instructions in the following section.

Caution! Exceeding 1400W (12A) will damage the device

Caution! For use on 120V 50/60Hz power lines. Do not use converters to adapt the device for 220/240 power lines

Safety Information

Extech Instruments does not assume any liability for damages to items or persons caused by improper handling or non-compliance with the safety notices. Any warranty claim will become null and void in such cases.

- Do not bypass the conductive ground wire; this can pose a lethal hazard in the event of a malfunction
- Keep this device out of the hands of children
- Only connect the EM100 Energy Logger to certified protected contact outlets (120V AC 50/60 Hz) that include a ground connection
- The connected load may not exceed 1400W (12A)
- The recommended operating temperature range is 50 to 122°F (10 to 50°C). High temperature, especially occurring during the measurement of high power loads, can lead to overheating and permanent instrument damage
- Avoid operating this instrument near flammable gases, vapors and dust
- Never operate this instrument when it is wet or in a damp environment
- When cleaning or servicing the instrument, disconnect it from any source of voltage. Note that capacitors in the device may still be charged even if the device is disconnected from all voltage sources
- In schools, training facilities, hobby and work-shops, qualified personnel must supervise the operation of this instrument
- In commercial institutions, observe the accident prevention regulations of the commercial trade organization for electric installations
- Do not insert any objects into this device

Meter Description

1. 120V socket
2. LCD Display
3. MIN/▼ button
4. MAX/▲ button
5. MODE button
6. SD Card Slot
7. ► button
8. 120V plug
9. Battery compartment

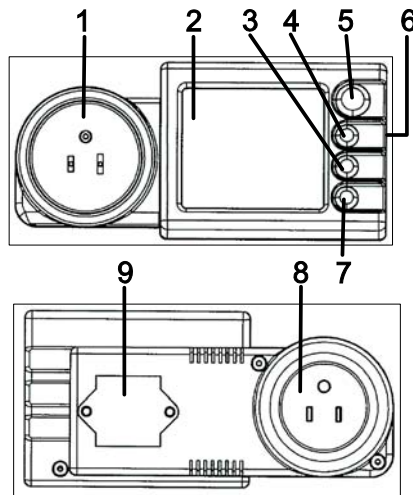

Operation

Do not use this instrument if it appears damaged, no longer works correctly, has been stored for a long period under unfavorable conditions, or has been placed under heavy stresses in transport. Remove this device from operation in the event that the instrument has been deemed unsafe to use.

Note: To program the settings, the unit must be plugged into a 120V outlet.

Initial Setting Mode

The instrument automatically enters the Setting Mode when the battery is inserted for the first time. Afterwards, during operation, the user can simultaneously press the **MODE** and the **right arrow** button for at least two seconds to access this Setting Mode.

A. ID Setting

1. While the ID digit is flashing, use the “**UP/DOWN**” arrows to select the desired number (0 to 9)
2. Press the “**MODE**” button to save the ID. The display will automatically change to the next programmable parameter.



B. Time Setting

Before setting the time, the desired time format must be selected. Use the “**UP/DOWN**” arrows to select the 12-hour format or the 24-hour format. Press the “**MODE**” button to save the date format. Use the “**UP/DOWN**” arrows to adjust “mm.dd yyyy” or the “dd.mm yyyy” format. Press the “**MODE**” button to save the setting and set the time.

1. While the hour digits are flashing, use the “**UP/DOWN**” arrows to select the desired hour.
2. Press the horizontal arrow button to go to the next pair of digits. Repeat this method until the time is set correctly.
3. Press the “**MODE**” button after setting the year (the year still flashing) to save the setting and start the clock.



C. Cost Settings

1. While a currency is flashing, use the “**UP/DOWN**” arrows to select a different currency. Available currencies are dollars (\$), Euros (€), SFr, and Pounds (£).
2. Press the “**right arrow**” button to go to the first cost digit.
3. While the first cost digit is flashing, use the “**UP/DOWN**” arrows to select the desired number.
4. Press the “**right arrow**” button to move to the next digit. Repeat this procedure until the costs are set correctly.
5. Press the “**MODE**” button after setting the last digit of cost 2 (while it is still flashing) to save the setting and start the unit.



Displays

Before connecting the EM100 to an outlet or power load, the desired power costs must be set. The procedure for entering the power costs is described under Initial Setting.

Display of Voltage, Current and Frequency (Power 1 Mode)

Immediately after the instrument is plugged into an outlet, the supply voltage, frequency of the supply voltage and consumption of a connected load are displayed in the LCD.

1. Press the **"MAX"** button to switch to the maximum display mode (only the highest reading will display). To return to normal mode, press the **"MAX"** button again (or simply wait 10 seconds and the display will auto-return).
2. Press the **"MIN"** button to switch to the minimum display mode (only the lowest reading will display). To return to normal mode, press the **"MIN"** button again (or simply wait 10 seconds and the display will auto-return).
3. Press and hold the **"MAX/MIN"** buttons for at least 2 seconds to clear and reset the MIN and MAX memories.
4. Press the **"MODE"** button to switch the display to active power, apparent power and cos phi.

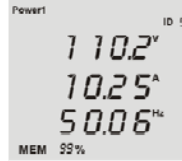

Display Active Power, Apparent Power, and Power Factor (cos phi) - (Power 2 Mode)

1. Press the **"MAX"** button to switch to the maximum display mode (only the highest reading will display). To return to normal mode, press the **"MAX"** button again (or simply wait 10 seconds and the display will auto-return).
2. Press the **"MIN"** button to switch to the minimum display mode (only the lowest reading will display). To return to normal mode, press the **"MIN"** button again (or simply wait 10 seconds and the display will auto-return).
3. Press and hold the **"MAX/MIN"** buttons for at least 2 seconds to clear and reset the MIN and MAX memories.
4. Press the **"MODE"** button to switch the display to Expended Energy in kWh (kilowatt hours) and Accrued Costs.

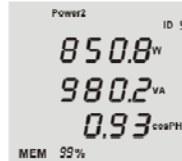

Display of 'Energy Consumed' and 'Energy Costs' (Consumption Mode)

The accrued costs are computed based on the two cost values programmed during initialization.

1. Press the **"right arrow"** button to access the value of cost 1 & 2. The display will automatically reset after 5 seconds.
2. Press the **"MODE"** button to switch the display to the History mode.

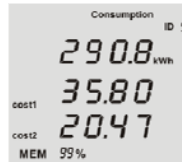

NOTE: Press the **"MODE"** button for at least three seconds to clear the Consumption, History, On-time, and Forecast values.

Display of Expended Energy and Energy Costs per day (History Mode)

The data for the current day is initially displayed.

1. Use the **"UP/DOWN"** arrows to scroll backwards up to nine days. The number on the upper right represents the number of days in the past.
2. Press the **"MODE"** button to switch the display to the Recording mode.



Display the Recorded data (On-Time Mode)

In the ON-time mode, the total recording time and the "ON" time are shown.

1. Use the "UP/DOWN" arrows to scroll backwards up to nine days. The number on the upper right represents the number of days in the past.
2. Press "MODE" to switch the display to the Cost Forecast mode.



Display of Cost Forecast (Forecast Mode)

The cost forecast screen shows the accumulated consumption. Based on this value and the recording time, the projected energy costs per month and year are calculated. Use the "UP/DOWN" arrows to shift the cost view from cost 1 to cost 2. Press the "MODE" button to switch the display to the Time mode.



Display of time (Time Mode)

The current time, date and year are displayed.

1. Press the "right arrow" button to display the time and date format. The display automatically resets after 5 seconds.
2. Press the "MODE" button to return to the Power 1 mode.



Memory (MEM) Record and Transfer Feature

The EM100 can store up to 200 days of recorded measurement data (approx. 300K) in its internal memory. The unit records a reading once per minute (each reading represents an average of 60 readings taken once per second).

Once the meter's internal memory is full, new readings replace the oldest readings (FIFO) so recording never stops. The user can, at any time, transfer readings from the internal memory to an SD memory card to avoid losing data.

The user can delete all of the meter's internal readings by pressing and holding the MODE button for at least 3 seconds.

The meter retains readings even when powered down. When the unit is powered up it begins recording where it left off.

A display of 'MEM 99%' indicates that there is 99% of the available internal memory space remaining. Since the meter can record up to 200 days' worth of data, the percentage display will take some time to decrement (approximately 1% every two days).

When the displayed memory value approaches zero, transfer the data to the SD card. When a card is inserted the card symbol appears. 'MEM%' flashes when the internal memory falls below 2%.

1. Press the "**right arrow**" to start the data transfer. A flashing arrow in the display indicates that data is transferring; the displayed counter increments as data transfers.
2. A flashing SD card in the display indicates that an error has occurred during transfer. Try the process again.
3. The data saving process is complete when the MEM 99% icon is displayed again.

SD Card Considerations:

1. The card must be configured in the FAT16 or FAT32 file format
2. The card is not write-protected
3. 5MB of free space is required
4. Previous data saved must be deleted
5. The unit supports SD card sizes of 64MB to 2GB
6. For 512MB to 2GB SD cards, the recommended file system is FAT32

Additional Notes

The connected loads should be operated normally when running a cost forecast. If an exact cost forecast is to be made per month and year, Extech recommends leaving the Energy Logger SD connected to the load for at least one day. The Energy Logger SD can thereby calculate an average power/ load and accrued costs more accurately. The longer the Energy Logger SD is connected, the more accurate the cost forecast.

The power delivered from a utility company is never completely stable and varies from place to place. For example, a voltage fluctuation of 1% per second for a calculated cost forecast over 5 minutes will never be as accurate as a cost forecast taken over 3 hours.

Note that some devices use more current than others immediately after switching on. The current usage decreases the longer the device is in use.

Maintenance

- Regularly inspect the instrument and SD card for damage
- To clean the device and LCD use a dry, soft cloth only. Do not use cleaning solutions
- Never immerse the device in water
- Maintenance or repairs may only be performed by a technician familiar with associated regulations

Replacing the Battery

The Energy Logger requires a cell battery type CR1620 which has a lifespan of approx. three (3) years. The battery is used to power the internal real time clock while the unit is powered off.

1. Turn the battery compartment screw and remove the battery compartment cover.
2. Remove the used battery from the instrument and replace it with a new one of the same type. Observe correct polarity when inserting the battery.
3. Replace the battery compartment cover and refasten the screw.

NOTE: Change the battery within 2 minutes to ensure that the real time clock does not reset. Check the date and time after replacing the battery and reset if necessary.

Replacing the Fuse

1. Remove the three Philips head screws surrounding the 120V plug on the rear.
2. Remove the socket housing and lift the socket on the front of the device.
3. Remove and replace the fuse.

Caution: Use only the proper size fuse.

Software for PC

PC Software is supplied allowing the user to transfer data from an SD card to a PC. (An SD card reader to PC hardware device is not included and must be obtained separately). The supplied software also displays recorded data, performs calculations, and permits the storage of data and configuration settings.

Instructions on the use of the software are included in the program's HELP utility. Install and run the software to access the HELP utility.

Specifications

Operating Voltage	120V AC 50/60 Hz
Max. connected power	1400W (1.8kW)
Max. current	12A
Operating temperature:	50 to 122°F (+10 and +45°C)
Battery type:	CR1620, 3V
Fuse type	12A, 125V, 1.25" slow blow
Cost setting range:	0.001 to 9.999
Power load display:	0.001 to 9999kWh max
Accuracy:	10W to 3500W: \pm (1% + 1 digit) 3W to 10W: \pm (1% + 3 digits) <3W: >1%
Approvals	ETL
Dimensions	(L x W x H): 6.5 x 3.2 x 3.1" (16.4 x 8.2 x 7.8cm)

Parameter Resolution

Voltage measurement	0.1V
Current measurement	0.01A
Frequency	0.01Hz
Active/Apparent Power	0.01W/0.01VA (for values under 100) 0.1W/0.1VA (for values between 100 and 1000) 1W/1VA (for over 1000)
Cos phi	0.01
Energy and costs	0.001 (for values under 10) 0.01 (for values between 10 and 100) 0.1 (for values between 100 and 1000) 1 (for values over 1000)
Rec time and ON time	0.001 (for values under 10) 0.01 (for values between 10 and 100) 0.1 (for values between 100 and 1000) 1 (for values over 1000)

Warranty

EXTECH INSTRUMENTS CORPORATION (a FLIR company) warrants this instrument to be free of defects in parts and workmanship for one year from date of shipment (a six month limited warranty applies on sensors and cables). If it should become necessary to return the instrument for service during or beyond the warranty period, contact the Customer Service Department at (781) 890-7440 ext. 210 for authorization or visit our website at www.extech.com (click on Contact Extech and go to Service Department to request an RA number). A Return Authorization (RA) number must be issued before any product is returned to Extech. The sender is responsible for shipping charges, freight, insurance and proper packaging to prevent damage in transit. This warranty does not apply to defects resulting from action of the user such as misuse, improper wiring, operation outside of specification, improper maintenance or repair, or unauthorized modification. Extech specifically disclaims any implied warranties or merchantability or fitness for a specific purpose and will not be liable for any direct, indirect, incidental or consequential damages. Extech's total liability is limited to repair or replacement of the product. The warranty set forth above is inclusive and no other warranty, whether written or oral, is expressed or implied.



Support line (781) 890-7440

Technical Support: Extension 200; E-mail: support@extech.com

Repair & Returns: Extension 210; E-mail: repair@extech.com

Product specifications subject to change without notice

For the latest version of this User Guide, Software updates, and other up-to-the-minute product information, visit our website: www.extech.com
Extech Instruments Corporation, 285 Bear Hill Road, Waltham, MA 02451

Copyright © 2009 Extech Instruments Corporation (a FLIR company)

All rights reserved including the right of reproduction in whole or in part in any form.