

Bigfoot
Level-Velocity Transmitter

Manual Series A.1.4

Note: This page has been left blank intentionally.

INDEX

INTRODUCTION	4
FUNCTION TEST.....	4
CALIBRATION	4
CONNECTIONS	5
INSTALLATION – SENSOR LOCATION.....	6
INSTALLATION - MOUNTING	9
4-20mA OUTPUTS	11
SAMPLE FLOW RATE CALCULATIONS	12
FIELD TROUBLESHOOTING	17
FREQUENTLY ASKED QUESTIONS.....	18
APPLICATIONS HOTLINE.....	19
PRODUCT RETURN PROCEDURE	19
SPECIFICATIONS.....	21
DIMENSIONS.....	21

IMPORTANT NOTE: This instrument is manufactured and calibrated to meet product specifications. Please read this manual carefully before installation and operation. Any unauthorized repairs or modifications may result in a suspension of the warranty.

Available in Adobe Acrobat pdf format

INTRODUCTION:

The Greyline Bigfoot Level-Velocity Transmitter measures level and velocity in open pipes and channels for irrigation. It is a submersible ultrasonic instrument designed for area-velocity flow measurement.

FUNCTION TEST:

1. Place the Bigfoot on a workbench (not in water) and connect 10-26 VDC power input to Red (+) and Black (-) wire ends. Use a battery or regulated DC power supply.
2. With an ammeter set in mA DC mode, connect to Velocity 4-20mA output Blue (+) and Black (-). Velocity output will be 4mA.
3. Connect Level 4-20mA output White (+) and Black (-) leads to your ammeter. Level output will be 4mA.
4. Place the Bigfoot (flat to the bottom) in a tray of water about 6"/150mm deep. Connect your ammeter leads to the Level 4-20mA output to observe an output reading >4mA. Connect your ammeter leads to the Velocity 4-20mA output and stir water over the submerged Bigfoot to observe velocity output >4mA.

CALIBRATION:

Bigfoot does not require field calibration.

Each Bigfoot is factory-calibrated to measure level from the bottom of the pipe or channel to the water surface (20mA equals 144 in / 3.658 m), and velocity where 20mA equals 9.84 ft/sec (3.0 m/sec).

CONNECTIONS:

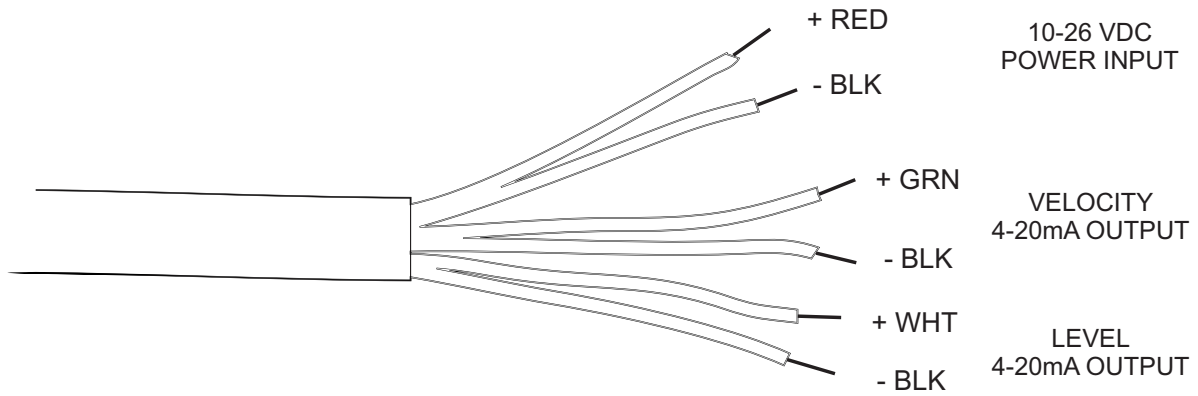

INSTALLATION – SENSOR LOCATION

For the most accurate flow measurement possible, careful consideration should be made to the placement of the sensor in relation to flow disturbances. In general, the best accuracy will occur where flow is evenly distributed across the channel/pipe and free of turbulence.

Specific installation considerations are listed and discussed in more detail below.

1. Open Discharges or Pipe/Channel Outfalls

When the Bigfoot sensor is to be mounted in front (upstream) of an open discharge or pipe/channel outfall, the sensor should be placed at least 5 times the maximum head level in front of the outfall:

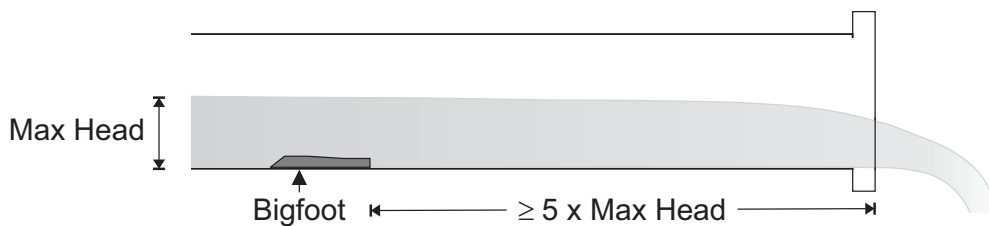

**Pipe / Channel
Side View**

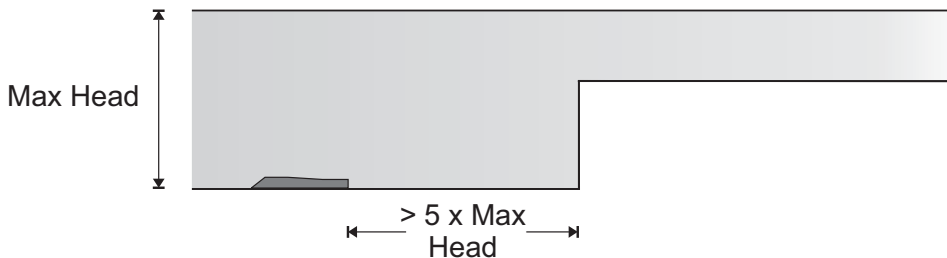
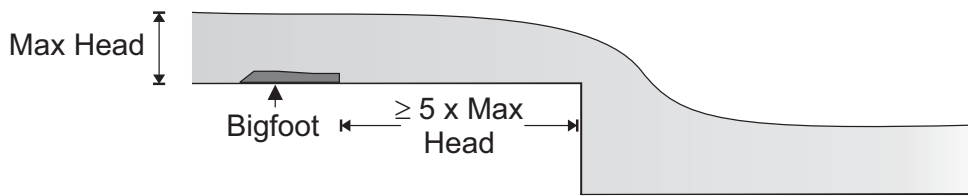

2. Hydraulic Dams

When the BIGFOOT sensor is to be mounted in front (upstream) of a hydraulic dam, or a Greyline VD pipe dam, the sensor should be placed at least 20 inches in front of the dam:

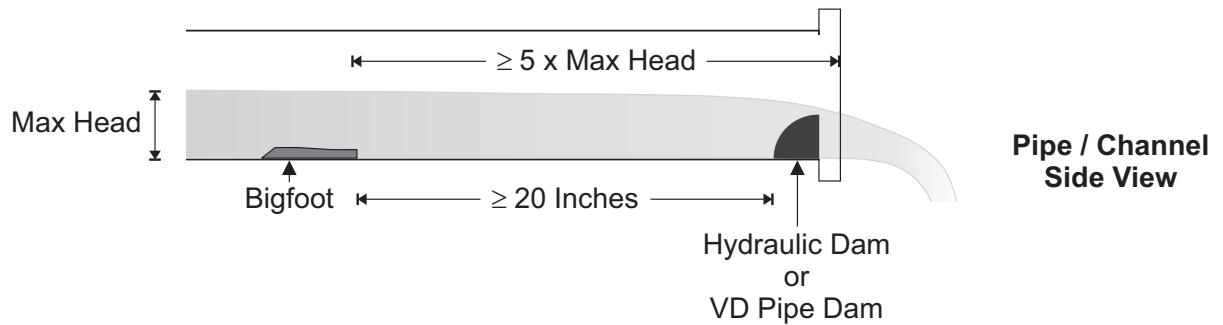

3. Pipe Grade

The pipe/channel in which the BIGFOOT sensor is mounted should not have a grade exceeding 3%:

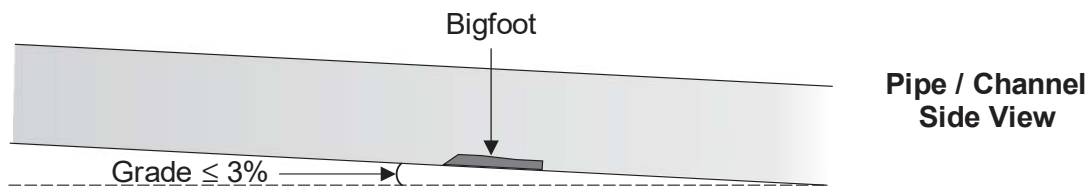

4. Flow Profile Distortion

The pipe/channel in which the BIGFOOT sensor is mounted should be free of bends, tees, sudden changes in slope, and there should not be objects in the pipe/channel which disturb the flow profile in front of the sensor.

In general, the BIGFOOT sensor should be mounted with at least 10 pipe diameters or channel widths of straight-run upstream, and 5 pipe diameters or channel widths downstream:

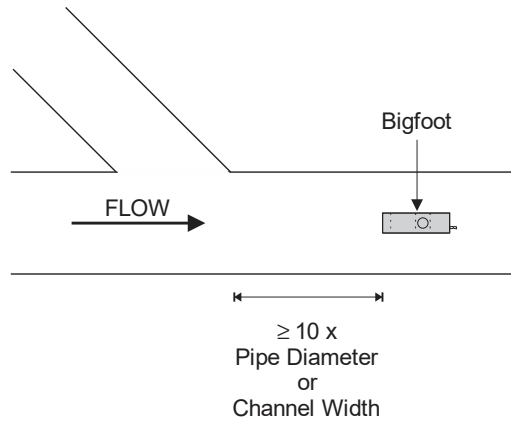

Top-Down View of Channel or Pipe

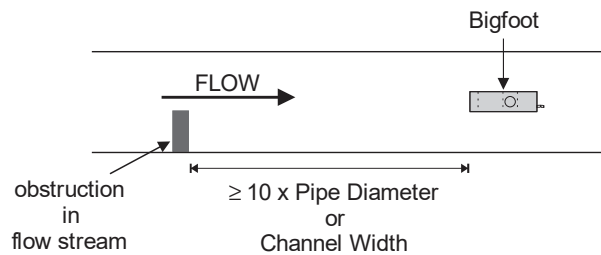
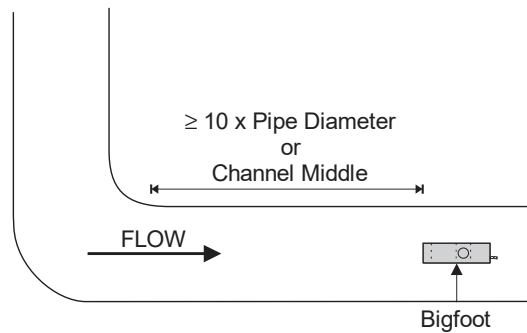

INSTALLATION - MOUNTING

Mount the Bigfoot using the MB-BF stainless steel bracket and hardware supplied. Ensure that the Bigfoot is parallel to the water surface (check with a level). Mount with the tapered end of the sensor pointing upstream and the cable pointing downstream.

Clip or tie wrap the Bigfoot cable securely to the pipe or channel wall.

Note: The Bigfoot requires a minimum water level of 1.8" (46 mm) above the bottom of the sensor.

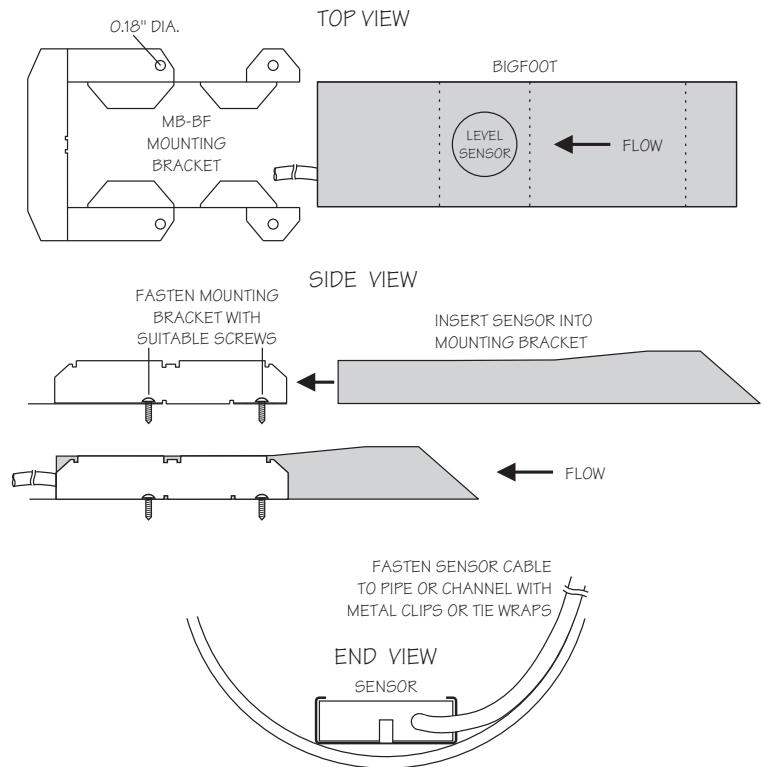

GOOD

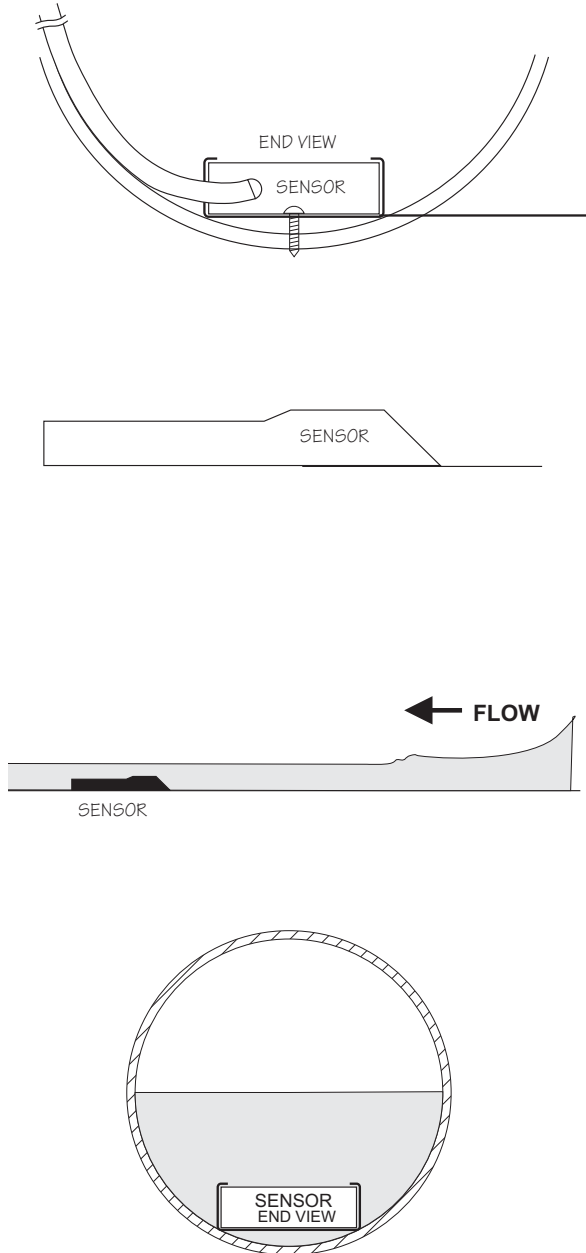

BAD

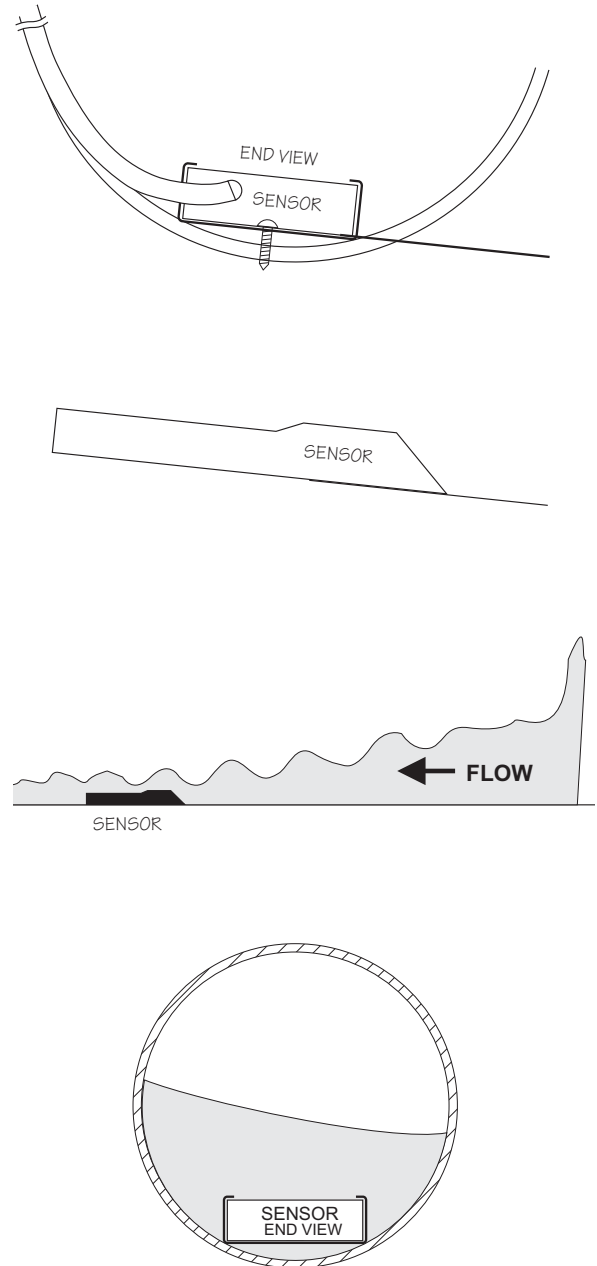

4-20mA OUTPUTS

Bigfoot level and velocity 4-20mA settings are factory-configured and cannot be changed.

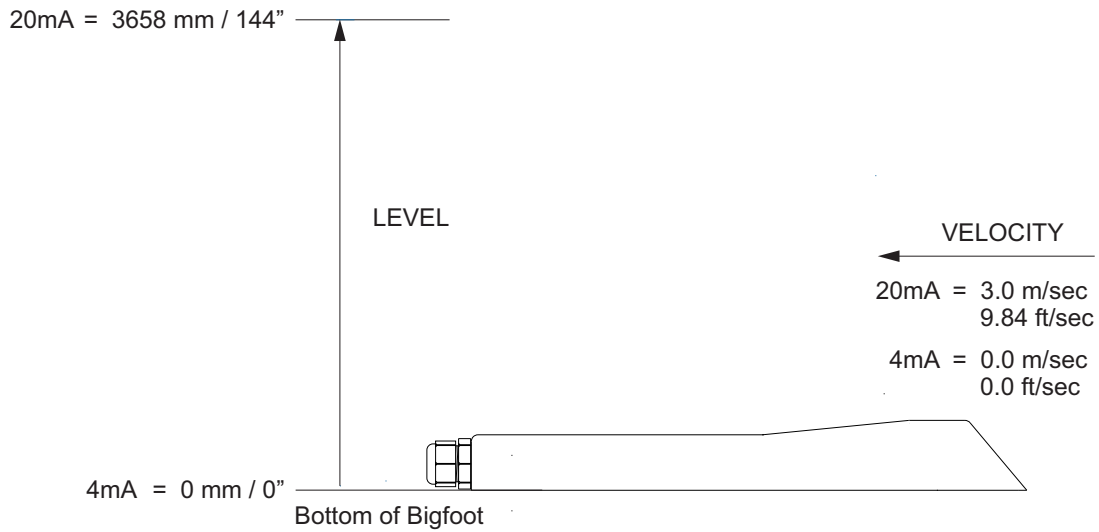

SAMPLE FLOW RATE CALCULATIONS

Calculating Level & Velocity from 4-20mA Outputs

Level is available as a 4-20mA output on the White (+) and Black (-) wire pair.

$$\text{Level in millimeters, } L_{mm} = \left[\left(\frac{\text{Measured mA} - 4 \text{ mA}}{16 \text{ mA}} \right) * 3657.6 \text{ mm} \right]$$

$$\text{Level in inches, } L_{in} = \left[\left(\frac{\text{Measured mA} - 4 \text{ mA}}{16 \text{ mA}} \right) * 144 \text{ in} \right]$$

Velocity is available as a 4-20mA output on the Blue (+) and Black (-) wire pair.

$$\text{Velocity in meters per second, } V_{m/s} = \left(\frac{\text{Measured mA} - 4 \text{ mA}}{16 \text{ mA}} \right) * 3.0 \text{ m/s}$$

$$\text{Velocity in feet per second, } V_{ft/s} = \left(\frac{\text{Measured mA} - 4 \text{ mA}}{16 \text{ mA}} \right) * 9.84 \text{ ft/s}$$

Rectangular Channel Flow Rate Calculation

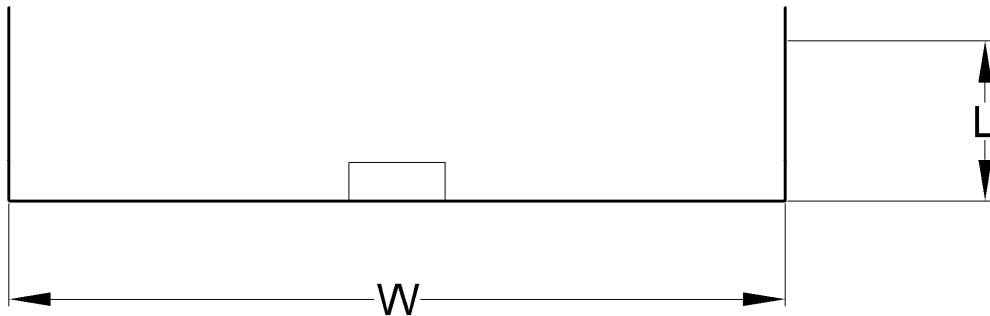

Required dimensions:

W = Width of channel. Customer provided.

W_m = Width of channel in meters.

W_{ft} = Width of channel in feet.

Calculate flow rate:

$$\text{Flow rate in cubic meters per hour, } \frac{m^3}{h} = W_m * L_{mm} * V_{m/s} * 3.6$$

$$\text{low rate in US gallons per minute, } \frac{gal}{m} = W_{ft} * L_{in} * V_{ft/s} * 37.4$$

Trapezoidal Channel Flow Rate Calculation

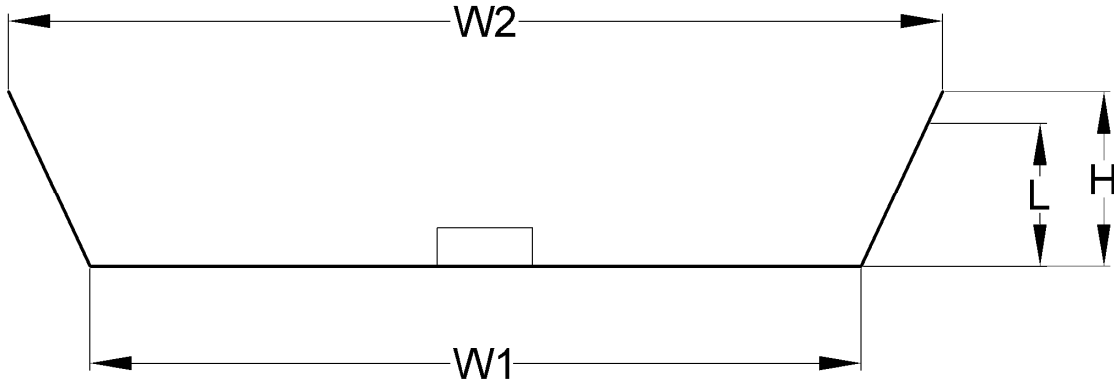

Required dimensions:

$W1$ = Width of bottom of channel. Customer provided.

$W2$ = Width of top of channel. Customer provided.

H = Height of channel at $W2$ dimension. Customer provided.

$W1_m$ & $W2_m$ = Width in meters.

$W1_{ft}$ & $W2_{ft}$ = Width in feet.

H_{mm} = Height of channel in millimeters.

H_{in} = Height of channel in inches.

Calculate flow rate:

$$\text{Flow rate in cubic meters per hour, } m^3/h = \left[W1_m + \frac{L_{mm} (W2_m - W1_m)}{H_{mm}} \right] * L_{mm} * V_{m/s} * 3.6$$

$$\text{Flow rate in US gallons per minute, } gal/m = \left[W1_{ft} + \frac{L_{in} (W2_{ft} - W1_{ft})}{H_{in}} \right] * L_{in} * V_{ft/s} * 37.4$$

Round Pipe Channel Flow Rate Calculation

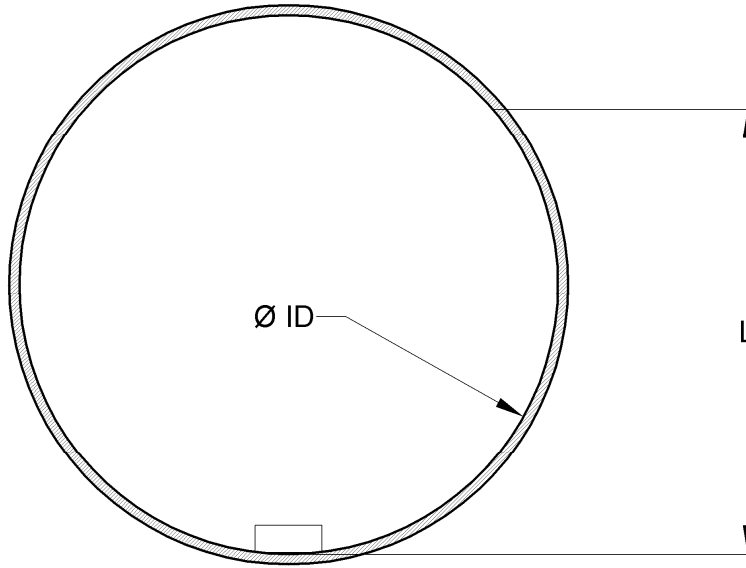

Required dimensions:

ID = Pipe internal diameter. Customer provided from either measurement or pipe chart.

ID_{mm} = ID in millimeters

ID_{in} = ID in inches

$$r_{mm} = \frac{ID_{mm}}{2}$$

$$r_{in} = \frac{ID_{in}}{2}$$

Fluid area can be acquired in two ways:

1. Lookup chart

To use the following lookup chart, first determine the % Level:

$$\% \text{ Level} = \frac{L_{mm}}{ID_{mm}}$$

or

$$\% \text{ Level} = \frac{L_{in}}{ID_{in}}$$

Find % Area from the lookup chart, based on the % Level:

ROUND PIPE LOOKUP CHART

% Level	% Area	% Level	% Area	% Level	% Area	% Level	% Area
0	0	25	19.5	50	50	75	80.4
0.5	0.1	25.5	20.1	50.5	50.6	75.5	81
1	0.2	26	20.7	51	51.3	76	81.5
1.5	0.3	26.5	21.2	51.5	51.9	76.5	82.1
2	0.5	27	21.8	52	52.5	77	82.6
2.5	0.7	27.5	22.4	52.5	53.2	77.5	83.2
3	0.9	28	22.9	53	53.8	78	83.7
3.5	1.1	28.5	23.5	53.5	54.5	78.5	84.2
4	1.3	29	24.1	54	55.1	79	84.7
4.5	1.6	29.5	24.6	54.5	55.7	79.5	85.2
5	1.9	30	25.2	55	56.4	80	85.8
5.5	2.2	30.5	25.8	55.5	57	80.5	86.3
6	2.5	31	26.4	56	57.6	81	86.8
6.5	2.8	31.5	27	56.5	58.3	81.5	87.3
7	3.1	32	27.6	57	58.9	82	87.8
7.5	3.4	32.5	28.2	57.5	59.5	82.5	88.2
8	3.7	33	28.8	58	60.1	83	88.7
8.5	4.1	33.5	29.4	58.5	60.8	83.5	89.2
9	4.5	34	30	59	61.4	84	89.7
9.5	4.8	34.5	30.6	59.5	62	84.5	90.1
10	5.2	35	31.2	60	62.6	85	90.6
10.5	5.6	35.5	31.8	60.5	63.3	85.5	91
11	6	36	32.4	61	63.9	86	91.5
11.5	6.4	36.5	33	61.5	64.5	86.5	91.9
12	6.8	37	33.6	62	65.1	87	92.4
12.5	7.2	37.5	34.3	62.5	65.7	87.5	92.8
13	7.6	38	34.9	63	66.4	88	93.2
13.5	8.1	38.5	35.5	63.5	67	88.5	93.6
14	8.5	39	36.1	64	67.6	89	94
14.5	9	39.5	36.7	64.5	68.2	89.5	94.4
15	9.4	40	37.4	65	68.8	90	94.8
15.5	9.9	40.5	38	65.5	69.4	90.5	95.2
16	10.3	41	38.6	66	70	91	95.5
16.5	10.8	41.5	39.2	66.5	70.6	91.5	95.9
17	11.3	42	39.9	67	71.2	92	96.2
17.5	11.8	42.5	40.5	67.5	71.8	92.5	96.6
18	12.2	43	41.1	68	72.4	93	96.9
18.5	12.7	43.5	41.7	68.5	73	93.5	97.2
19	13.2	44	42.4	69	73.6	94	97.5
19.5	13.7	44.5	43	69.5	74.2	94.5	97.8
20	14.2	45	43.6	70	74.8	95	98.1
20.5	14.7	45.5	44.3	70.5	75.3	95.5	98.4
21	15.3	46	44.9	71	75.9	96	98.7
21.5	15.8	46.5	45.5	71.5	76.5	96.5	98.9
22	16.3	47	46.2	72	77.1	97	99.1
22.5	16.8	47.5	46.8	72.5	77.6	97.5	99.3
23	17.4	48	47.5	73	78.2	98	99.5
23.5	17.9	48.5	48.1	73.5	78.8	98.5	99.7
24	18.5	49	48.7	74	79.3	99	99.8
24.5	19	49.5	49.4	74.5	79.9	99.5	99.9
25	19.5	50	50	75	80.4	100	100

Calculate actual area based on % area:

$$\text{Area in square millimeters, } A_{mm^2} = \% \text{ Area} * \pi * r_{mm}^2$$

$$\text{Area in square inches, } A_{in^2} = \% \text{ Area} * \pi * r_{in}^2$$

Calculate flow rate:

$$\text{Flow rate in cubic meters per hour, } m^3/h = A_{mm^2} * V_{m/s} * 0.0036$$

$$\text{Flow rate in US gallons per minute, } gal/m = A_{in^2} * V_{ft/s} * 3.117$$

2. Equation:

Calculate flow rate:

Flow rate in cubic meters per hour, m^3/h

$$= \left[r_{mm}^2 \cos^{-1} \left(\frac{r_{mm} - L_{mm}}{r_{mm}} \right) - (r_{mm} - L_{mm}) \sqrt{2r_{mm}L_{mm} - L_{mm}^2} \right] * V_{m/s} * 0.0036$$

Flow rate in US gallons per minute, Gal/m

$$= \left[r_{in}^2 \cos^{-1} \left(\frac{r_{in} - L_{in}}{r_{in}} \right) - (r_{in} - L_{in}) \sqrt{2r_{in}L_{in} - L_{in}^2} \right] * V_{ft/s} * 3.12$$

FIELD TROUBLESHOOTING

Loss of Level or Velocity 4-20mA signal

- Confirm 10-26VDC power input to the Bigfoot.
- Check electrical connections.
- Clean accumulated sediment or debris from the Bigfoot and mounting area of the pipe or channel.

Level readings high, low or erratic

- Confirm 10-26VDC power input to the Bigfoot.
- Confirm that Bigfoot is installed flat on the bottom of the channel or invert of the pipe.
- Bigfoot mounted too close to elbow or flow obstruction.
- Check electrical connections.
- Isolate output from controller input and measure directly with multimeter. Different behavior with wires disconnected could mean a problem with controller.

Velocity readings high, low or erratic

- Confirm 10-26VDC power input to the Bigfoot.
- Bigfoot mounted too close to elbow or flow obstruction.
- Check electrical connections.
- Isolate output from controller input and measure directly with multimeter. Different behavior with wires disconnected could mean a problem with controller.

FREQUENTLY ASKED QUESTIONS

What precautions should be taken for freezing water?

Swelling ice can damage the Bigfoot and floating ice can damage the cable. Bigfoot should be removed from the water before freezing season. It can be stored out of water in temperatures down to -15°C / 5°F.

Will Bigfoot function with sediment build-up?

Best results and performance will be obtained by selecting a mounting location where sediment build-up does not occur. Bigfoot will tolerate some accumulation of sediment but signal strength will eventually diminish or be lost entirely. Bigfoot can be elevated above the pipe or channel floor to prevent the accumulation of sediment or a regular cleaning program can be established.

How long can Bigfoot cable be extended?

10-26VDC power input wire length can be extended but a gauge of wire should be selected to ensure that voltage does not drop below 10VDC.

4-20mA signal outputs are rated for 1000 ohm resistive loads and can be extended long distances without significant loss of power. Consult Greyline Help Desk for specific advice for your application.

Extended cable should be connected through a watertight junction box with terminal connections.

Can multiple Bigfoot be installed in the same channel?

Yes, multiple unit installations are recommended for larger channels or pipes. Advanced Bigfoot electronics automatically ensure that there is no crosstalk between transmitters.

APPLICATIONS HOTLINE

For applications assistance, advice or information on any Greyline Instrument contact your Sales Representative, write to Greyline or phone the Applications Hotline below:

United States:	Tel: 315-788-9500	Fax: 315-764-0419
Canada:	Tel: 613-938-8956	Fax: 613-938-4857
Toll Free:	888-473-9546	
Email:	info@greyline.com	
Web Site:	www.greyline.com	

Greyline Instruments Inc.

USA:
11451 Belcher Road South
Largo, FL 33773

Canada:
16456 Sixsmith Drive
Long Sault, Ont. K0C 1P0

PRODUCT RETURN PROCEDURE

Instruments may be returned to Greyline for service or warranty repair.

1 Obtain an RMA Number from Greyline -

Before shipping a product to the factory please contact Greyline by telephone, fax or email to obtain an RMA number (Returned Merchandise Authorization). This ensures fast service and correct billing or credit.

When you contact Greyline please have the following information available:

1. Model number / Software Version
2. Serial number
3. Date of Purchase
4. Reason for return (description of fault or modification required)
5. Your name, company name, address and phone number

2 Clean the Sensor/Product -

Important: unclean products will not be serviced and will be returned to the sender at their expense.

1. Rinse sensor and cable to remove debris.
2. If the sensor has been exposed to sewage, immerse both sensor and cable in a solution of 1 part household bleach (Javex, Clorox etc.) to 20 parts water for 5 minutes. Important: do not immerse open end of sensor cable.
3. Dry with paper towels and pack sensor and cable in a sealed plastic bag.
4. Wipe the outside of the enclosure to remove dirt or deposits.
5. Return to Greyline for service.

LIMITED WARRANTY

Greyline Instruments warrants, to the original purchaser, its products to be free from defects in material and workmanship for a period of one year from date of invoice. Greyline will replace or repair, free of charge, any Greyline product if it has been proven to be defective within the warranty period. This warranty does not cover any expenses incurred in the removal and re-installation of the product.

If a product manufactured by Greyline should prove defective within the first year, return it freight prepaid to Greyline Instruments along with a copy of your invoice.

This warranty does not cover damages due to improper installation or handling, acts of nature, or unauthorized service. Modifications to or tampering with any part shall void this warranty. This warranty does not cover any equipment used in connection with the product or consequential damages due to a defect in the product.

All implied warranties are limited to the duration of this warranty. This is the complete warranty by Greyline and no other warranty is valid against Greyline. Some states do not allow limitations on how long an implied warranty lasts or limitation of incidental or consequential damages, so the above limitations or exclusions may not apply to you.

This warranty gives you specific legal rights, and you may also have other rights which vary from state to state.

Greyline Instruments Inc.

SPECIFICATIONS

- Level Measurement Range:** 1.8 to 144" (45.8 to 3658 mm) from bottom of sensor
- Velocity Measurement Range:** 0.1 to 9.84 ft/sec (0.03 to 3.0 m/sec)
- Outputs:** Internally powered, 4-20mA Velocity and 4-20mA Level, 1000 Ohm at 24VDC input power
- Power Input:** 10-26VDC, 150mA Max.
- Operating Temperature:** 32° to 150°F (0° to 65°C)
- Storage Temperature:** 5° to 150°F (-15° to 65°C)
- Accuracy:** Level: $\pm 0.25\%$ of actual Range or 0.04" (1 mm), whichever is greater.
Velocity: $\pm 2\%$ of Reading. 0 or ± 0.02 ft/s, whichever is greater
- Repeatability and Linearity:** $\pm 0.25\%$
- Temperature Compensation:** Automatic, continuous
- Sensor Cable:** 50 ft (15 m) submersible 6-conductor, 18 ga.
Optional: 100 ft (30 m) submersible 6-conductor, 18 ga.
- Sensor Mounting:** Includes MB-BF stainless steel mounting bracket
- Exposed Materials:** PVC, epoxy resin, ultem, polyurethane
- Approximate Shipping Weight:** 4.4 lbs (2 kg)

DIMENSIONS

