



**Sieger Apex**

# SAFETY

Ensure that you read and understand this handbook **BEFORE** installing/operating the equipment. Pay particular attention to the Safety Warnings.

## WARNINGS

1. This gas detection equipment is certified for and intended for use in potentially hazardous areas. Install and use the equipment in accordance with current local and national regulations.
2. Refer to the control drawings included in this document when installing the certified components.
3. Operators should be fully aware of the action to be taken if the gas concentration exceeds alarm level.
4. Do not modify or alter the construction of any of the units as essential safety and certification requirements may be invalidated.
5. The equipment is not suitable for use in oxygen enriched atmospheres (>21%V/V). Oxygen deficient atmospheres (<10% V/V) may suppress some sensor outputs.
6. The equipment is intended for use at atmospheric pressure only and should not be used in pressures exceeding 1.1 bar.

### Transmitter Unit only

1. **INPUT VOLTAGE MUST NOT EXCEED THE STATED MAXIMUM (32V DC) AS ESSENTIAL SAFETY REQUIREMENTS MAY BE INVALIDATED AND THE UNIT MAY BE PERMANENTLY DAMAGED.**
2. Alarms should not be reset until it is confirmed that gas is **not** present.
3. Hazardous voltages may exist at alarm contacts. Ensure power is disconnected at source prior to servicing contacts.
4. Gas events occurring while accessing the Transmitter Unit menus will not be reported locally.
5. Overrange flammable gas readings may indicate an explosive concentration of gas.

### Certified Sensor only

1. When installed to measure flammable gas it is essential that either the Transmitter unit or control network is configured to latch the overrange condition. If the Transmitter unit local relays are used this should be achieved by enabling the overrange latching function of the Transmitter unit. Depletion of oxygen as a consequence of displacement by flammable gas can result in the gas reading returning to zero.
2. Change gas cartridges using the procedure described in this handbook. Failure to correctly follow the procedure could result in the wrong cartridge being installed, and possibly non-detection of events. Alternatively, extraneous alarms could be triggered by chemicals detected but not of concern at a particular location.
3. Sensor cartridges may contain corrosive solutions. Dispose of in accordance with local and national regulations.
4. During usage, as some gases may be hazardous, outlets from accessories, etc., e.g. Flow Housing, should exhaust to a safe area.

---

# SAFETY

---

## CAUTIONS

1. Only the combustible gas detection portion of this instrument has been assessed for performance by CSA.
2. Refer to local or national regulations relative to installation and use at the site.
3. Installation should consider not only optimum siting for gas detection related to potential leak points, gas characteristics and ventilation but also placement where the potential for mechanical damage is minimised or avoided.
4. Observe precautions for handling electrostatic discharge sensitive devices when accessing the interior of the Transmitter Unit.
5. Calibration procedures should only be performed by qualified personnel.
6. Ensure that when forcing signals on the Transmitter Unit's output that the effects on the network and controller are understood.
7. Ensure that the Apex Transmitter Unit or Junction Box flamepath is not damaged during dismantling procedures. The flamepath is formed by the mating surfaces of the unit's top and base.
8. During installation/maintenance only use the supplied parts. Replacement with alternatives will invalidate certification.
9. Exposure to fluorinated hydrocarbons or silicones will poison the sensor beads on catalytic sensor cartridges. If a sensor is known to have been poisoned then it must be re-calibrated. If not sure then flow gas over the sensor and if the reading is incorrect re-calibrate within the cartridge's tolerance value.
10. Only cartridges with the following part numbers can be fitted to the Certified Sensor:  
2110B30x0, 31x0, 32x0, 33x0, 34x0 series  
2110B3700 - 2110B3999 range

*Note:* Certified to **CSA C22.2 No. 152** only when fitted with specific cartridges.  
See specifications for details.

*Performance assessed to EN50054/57 when fitted with cartridges  
Part No: 2110B3701& 2110B3704. See specifications for detail.*

11. When compliance with the ATEX EN50054 performance standard is required the warning and inhibit current shall not be configured to a value between than 3.1mA and 4.9mA
12. Do not use the unit where the temperature is lower than -40°C (-40°F) or higher than +65°C (149°F).
13. Exposures to gas above the recommended range may result in ambiguous readings and may require subsequent re-calibration of the sensor.
14. Review cartridge data sheets for operating temperatures and humidities, which are determined on a cartridge by cartridge basis.
15. Dispose of in accordance with local disposal regulations. Materials used:

### **Transmitter Unit**

Main Body: Stainless Steel  
User Interface: Zinc Alloy.

### **Certified Sensor**

Main Body: Stainless Steel

### **Certified Junction Box**

Main body: Stainless steel.

---

## HELP US TO HELP YOU

---

Every effort has been made to ensure the accuracy in the contents of our documents, however, Zellweger Analytics Limited can assume no responsibility for any errors or omissions in our documents or their consequences. Zellweger Analytics Limited would greatly appreciate being informed of any errors or omissions that may be found in our documents. To this end we include the following form for you to photocopy, complete and return to us so that we may take the appropriate action.

<p>To: Marketing Communications Zellweger Analytics Limited Hatch Pond House 4 Stinsford Road Nuffield Estate POOLE. Dorset BH17 0RZ United Kingdom</p> <p>Tel.: +44 (0) 1202 676161 Fax.: +44 (0) 1202 678011 E-mail: sales@zelana.co.uk</p>	<p>From: Address:</p> <p>Tel.: Fax.: E-mail:</p>
---	--

I suggest the following corrections/changes be made to: .....

Marked up copies attached (as appropriate): Yes / No

Please inform me of the outcome of this change: Yes / No

For Marketing Communications, Zellweger Analytics Limited:

Actioned By:  
Date:

Response:  
Date:

---

# CONTENTS

---

<b>SAFETY</b>	<b>2</b>
<b>HELP US TO HELP YOU</b>	<b>4</b>
<b>1. INTRODUCTION</b>	<b>8</b>
<b>2. OVERVIEW</b>	<b>10</b>
<b>2.1 Transmitter Unit</b>	<b>10</b>
<b>2.2 Certified Sensor</b>	<b>12</b>
<b>2.3 Accessories</b>	<b>14</b>
2.3.1 Certified Junction Box	14
2.3.2 Collecting Cone	16
2.3.3 Flow Housing	17
2.3.4 Weather Housing	18
2.3.5 Sunshade	18
2.3.6 Oxygen Transducer Adaptor	19
2.3.7 Filters	19
<b>3. INSTALLATION</b>	<b>20</b>
General Installation Guidelines	21
<b>3.1 Transmitter Unit and Certified Sensor</b>	<b>22</b>
3.1.1 Installing the Transmitter Unit	22
3.1.2 Fitting the Certified Sensor	25
3.1.3 Installing the Gas Sensing Cartridge	27
3.1.4 Transmitter Unit Configuration	29
<b>3.2 Certified Junction Box and Certified Sensor</b>	<b>31</b>
3.2.1 Installing the Certified Junction Box	32
3.2.2 Fitting the Certified Sensor	34
3.2.3 Installing the Gas Sensing Cartridge	36
3.2.4 Certified Junction Box Configuration	37
<b>3.3 LonWorks Communications Board</b>	<b>38</b>
3.3.1 Removing the Transmitter Unit top	39
3.3.2 Removing the Main PCB assembly from the top	40
3.3.3 Fitting the LonWorks Communication Board to the Main PCB	40
3.3.4 Refitting the Main PCB Assembly into the Top	41
3.3.5 Connecting the LonWorks Network Wiring	42
3.3.6 Refitting the Transmitter Unit Top	43
<b>3.4 Accessories</b>	<b>46</b>
3.4.1 Flow Housing, Weather Protection, Collecting Cone	46
3.4.2 Sunshade	47

---

# CONTENTS

---

<b>4. OPERATION</b>	<b>49</b>
<b>4.1 Display and Control Buttons</b>	<b>49</b>
4.1.1 LCD screen	50
4.1.2 Control buttons	50
<b>4.2 Start-up</b>	<b>51</b>
<b>4.3 Passwords</b>	<b>52</b>
4.3.1 Setting/changing passwords	53
4.3.2 Password reset	55
<b>4.4 Menus</b>	<b>56</b>
4.4.1 Calibration Menu	57
4.4.2 Configuration Menu	63
4.4.3 Display Menu	71
4.4.4 History Log Menu	74
4.4.5 Change Passwords Menu	75
4.4.6 Reset Passwords	76
<b>4.5 User Tasks</b>	<b>77</b>
<b>4.6 Fault Diagnosis</b>	<b>78</b>
4.6.1 Displayed Error Messages	78
4.6.2 General Faults	79
4.6.3 4-20mA output signal ranges and fault conditions	80
4.6.4 Clearing latched alarms	81
<b>4.7 System Calibration</b>	<b>82</b>
<b>4.8 Binding Communication Boards to Networks</b>	<b>87</b>
<b>5. MAINTENANCE</b>	<b>89</b>
<b>5.1 Routine maintenance schedule</b>	<b>89</b>
<b>5.2 Maintenance Procedures /Parts Replacement</b>	<b>90</b>
5.2.1 Changing the Certified Sensor Filter	90
5.2.2 Changing the Certified Sensor Cartridge	91
5.2.3 Changing the Certified Sensor	95
5.2.4 Changing the Transmitter Unit Front Panel Assembly	98
<b>APPENDIX A - SPECIFICATIONS</b>	<b>100</b>
<b>A.1 Transmitter Unit and Sensor</b>	<b>100</b>
A.1.1 Gases and Ranges	100
A.1.2 Input/Output	100
A.1.3 Monitoring functions	102
A.1.4 Performance	102

---

# CONTENTS

---

A.1.5	Environmental	102
A.1.6	Storage (excluding cartridge)	102
A.1.7	EMC	103
A.1.8	Enclosure	103
A.1.9	Configuration	103
A.1.10	Certification and Approvals	103
A.1.11	Calibration intervals	105
<b>A.2</b>	<b>Cartridges</b>	<b>105</b>
A.2.1	Cartridge tables	105
<b>A.3</b>	<b>Accessories</b>	<b>111</b>
A.3.1	Certified Junction Box	111
A.3.2	Sunshade	112
A.3.3	Flow Housing	113
A.3.4	Weather Protection	113
A.3.5	Collecting Cone	113
A.3.6	Oxygen Transducer Adaptor	113
<b>A.4</b>	<b>LonWorks Communications Board</b>	<b>113</b>
A.4.1	LonWorks Network Variables	114
A.4.2	Node Object	114
A.4.3	Sensor Object	116
A.4.4	Virtual Function Block	117
A.4.5	Implementation of nviRequest	118
A.4.6	Interpretation of nvoStatus	119
<b>APPENDIX B - CERTIFICATION</b>		<b>120</b>
<b>B.1</b>	<b>Transmitter Unit</b>	<b>120</b>
<b>B.2</b>	<b>Certified Sensor</b>	<b>121</b>
<b>B.3</b>	<b>Certified Junction Box</b>	<b>123</b>
<b>B.4</b>	<b>Accessories</b>	<b>124</b>
<b>B.5</b>	<b>Control Drawings</b>	<b>125</b>
<b>APPENDIX C - ACCESSORIES &amp; SPARE PARTS</b>		<b>127</b>
<b>C.1</b>	<b>Accessories</b>	<b>127</b>
<b>C.2</b>	<b>Digital Communications Board</b>	<b>127</b>
<b>C.3</b>	<b>Spares</b>	<b>127</b>
<b>APPENDIX D - GLOSSARY</b>		<b>128</b>

---

# 1. INTRODUCTION

---

Apex is a gas detection system that consists of a Transmitter Unit, a certified gas sensor and a set of accessories. The Transmitter Unit, Certified Sensor and Certified Junction Box accessory are all certified for use in potentially hazardous areas and are protected against water and dust ingress to IP67.

Typical working environments are oil and gas distribution, petroleum extraction and chemical manufacture.

System installation is straightforward. Components should be installed in accordance with the procedures described in this handbook and to local or national installation codes of practice.

The Transmitter Unit acts as the local system controller and features a large LCD screen and four control buttons that are used for operator interaction. Control of the system is implemented via a system of software-driven hierarchical menus that include such operations as cartridge change, system configuration, etc. Remote control of the system can be made via an optional digital interface.

The Transmitter Unit can have the Certified Sensor fitted to it locally or mounted remotely using a Certified Junction Box and additional cabling up to 100 metres long.

The Transmitter Unit provides a 4-20mA output, as well as an optional digital output. Relays for operating locally-wired devices, such as lights, horns, etc. are included. The range of accessories enhances operation of the system and includes a collecting cone, weather protection, etc.

The Certified Sensor is compatible with a range of more than 40 sensor cartridges that use catalytic bead, thick film and electrochemical cells.

The interchangeable sensor cartridge determines which gas is monitored. All gas cartridges are fully calibrated when supplied.

The Certified Sensor uses intrinsically safe circuits to drive the cartridges. Cartridges may therefore be exchanged without powering down even in the presence of an explosive gas atmosphere.

Field calibration of the sensor, if required, is also possible. The cartridges available are listed in **Appendix A**.

The output from the sensor provides a gas concentration reading that is displayed on the LCD screen on the front of the Transmitter Unit and is also transmitted on the 4-20mA output and the optional digital interface.



---

# 1. INTRODUCTION

---

This handbook consists of the following parts:

- **Chapter 1**      **Introduction**
- **Chapter 2**      **Overview**
- **Chapter 3**      **Installation**
- **Chapter 4**      **Operation**
- **Chapter 5**      **Maintenance**
- **Appendix A**    **Specifications**
- **Appendix B**    **Certification**
- **Appendix C**    **Accessories & Spare Parts**
- **Appendix D**    **Glossary**

## Information notices

The types of information notices used throughout this handbook are as follows:



### **WARNING**

Indicates hazardous or unsafe practice which could result in severe injury or death to personnel.

*Caution:* Indicates hazardous or unsafe practice which could result in minor injury to personnel, or product or property damage.

*Note:* Provides usefull/helpfull/additional information.

## Trademarks

The following trademarks are used in this handbook:

Teflon® and Freon® are registered trademarks of E.I. DuPont de Nemours and Co.

LonWorks®, Echelon®, Neuron®, and LonTalk® are registered trademarks of Echelon Corporation.

If more information outside the scope of this technical handbook is required please contact Zellweger Analytics.

---

## 2. OVERVIEW

---

This chapter provides an overview of the following system components, and provides their dimensions:

- **Transmitter Unit**
- **Certified Sensor**
- **Accessories**

For installation information see **Chapter 3**.

Also see drawing **2110C8049 Outline Dimensions of Certified Transmitter, Sensor & Accessories** (available on request from Zellweger Analytics).

### 2.1 TRANSMITTER UNIT

The Transmitter Unit provides a mounting point for a Certified Sensor and contains all the electronics associated with the gas detection system.

It features an LCD display screen that displays the controlling software menu system, and also a set of buttons that let an operator/user interact with the system by accessing the menus and responding to displayed messages.

The Transmitter Unit is shown with a Certified Sensor fitted.

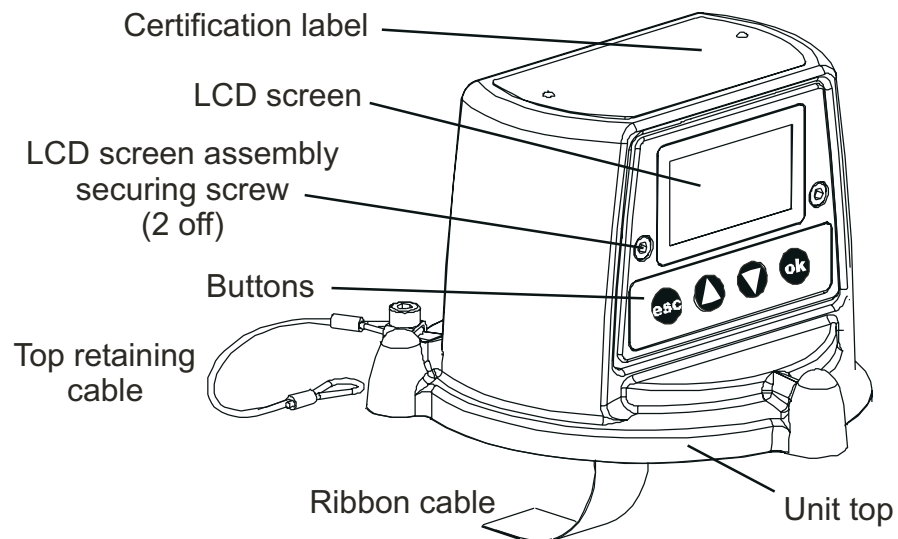

## 2. OVERVIEW

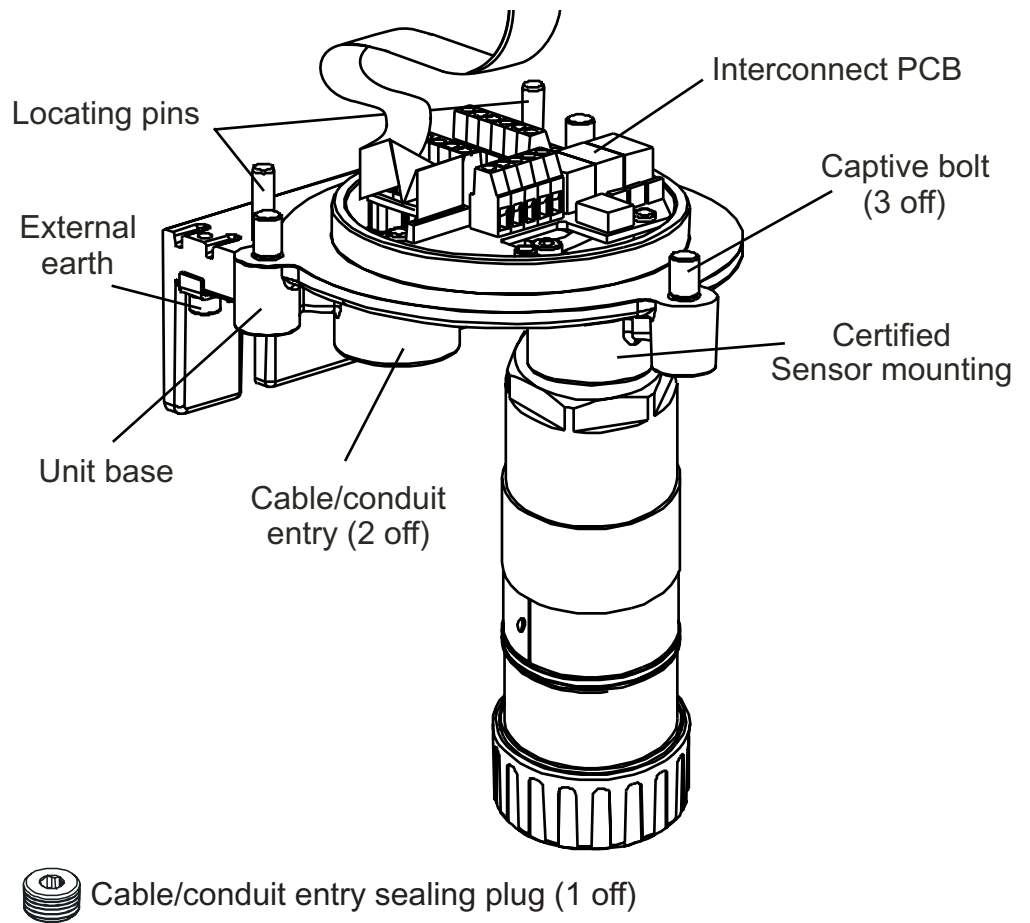

---

## 2. OVERVIEW

---

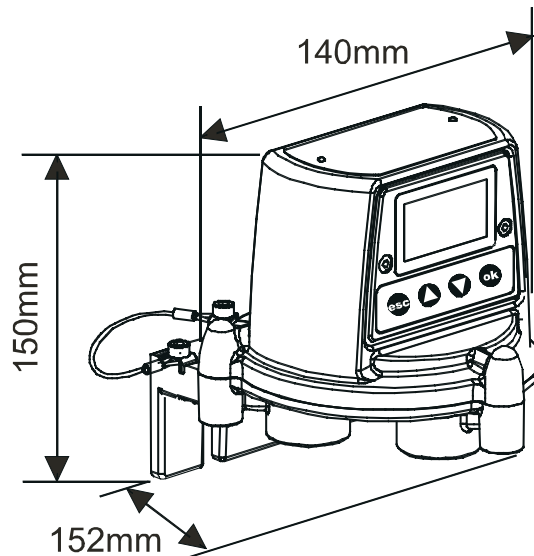

### 2.2 CERTIFIED SENSOR

The Certified Sensor consists of the sensor body and one of four types of replaceable gas cartridge and the electronics to output gas sensing data to the Apex Transmitter Unit. The Certified Sensor can be fitted with any one of a number of accessories, the majority of which fit in place of the sensor cap (see 2.3).

The four types of cartridge are:

- **electrochemical cell**
- **catalytic (SG16 type)**
- **oxygen**
- **thick film**

**Caution:** *Only cartridges with the following part numbers can be fitted to the Certified Sensor:*

**2110B30x0, 31x0, 32x0, 33x0, 34x0 series**

**2110B3700 - 2110B3999 range**

Certified Sensor approved to **CSA C22.2 No. 152** only when fitted with specific cartridges installed. See specifications for details.

The sensor should be mounted in the vertical orientation with the cartridge facing downwards.

## 2. OVERVIEW

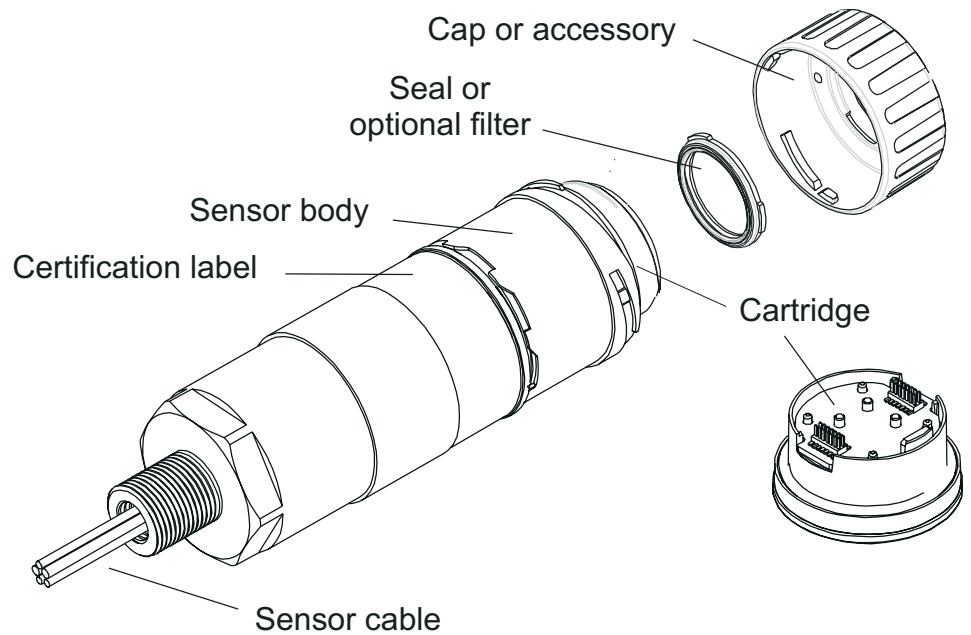

All the gas cartridges are the same size except for the Oxygen cartridge, which is larger than the rest. To allow for its extra length an Oxygen Transducer Adaptor, supplied with the cartridge, mounts on the sensor bayonet fixing. The Oxygen cartridge is then inserted and the cap or accessory fitted.

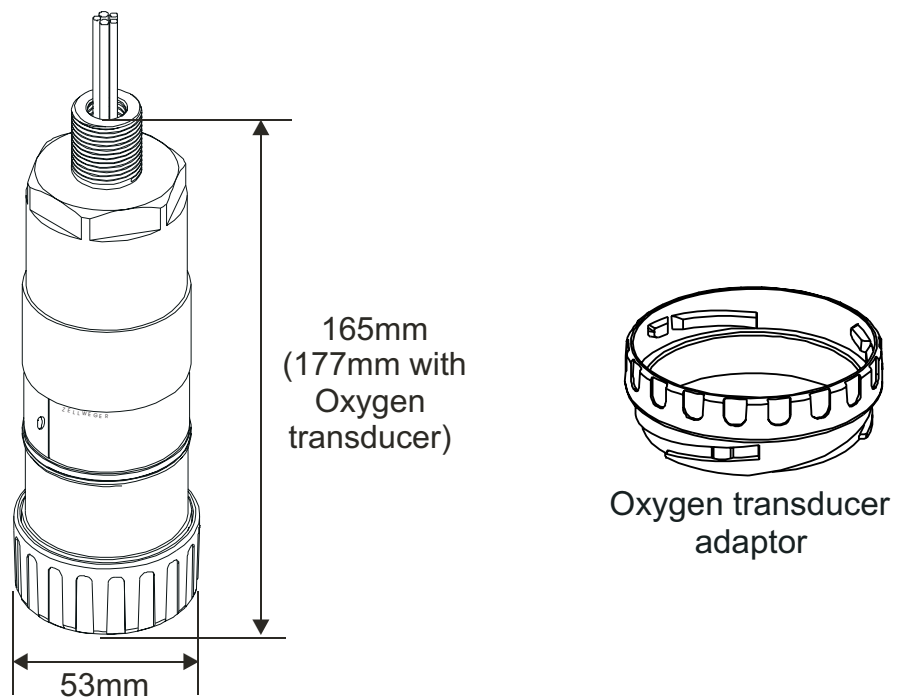

---

## 2. OVERVIEW

---

### 2.3 ACCESSORIES

The Apex accessories provide optional equipment that can, for example, protect the Certified Sensor in harsh external environments and assist gas monitoring. All of the sensor accessories are easily fitted.

The following accessories are available:

- **Certified Junction Box (Part Numbers: ATEX EEXd 2110B2100, UL/CSA [Explosion proof] 2110B2103)** - two types for remote mounting a Certified Sensor.
- **Collecting Cone** (Part No: 2110B2151) - for use when monitoring lighter-than-air gases.
- **Flow Housing** (Part No: 2110B2140) - to aid sensor calibration and gas sample monitoring.
- **Weather Housing** (Part No: 2110B2150) - to protect the sensor from harsh weather.
- **Sunshade** (Part No: 2110B2152) - to protect the sensor from direct sunlight.
- **Filters** - three different filters to provide protection for the gas sensing cartridge.
- **O<sub>2</sub> Transducer Adaptor** - supplied with Oxygen cartridges to allow for their longer length over standard cartridges.

#### 2.3.1 Certified Junction Box

**Part Numbers:**

<b>ATEX EEXd</b>	<b>2110B2100</b>
<b>UL/CSA (Explosion proof)</b>	<b>2110B2103</b>

The Certified Junction Box accessory is used to mount a Certified Sensor remotely from the Transmitter Unit, and provides a connection point for the sensor and field wiring.

## 2. OVERVIEW

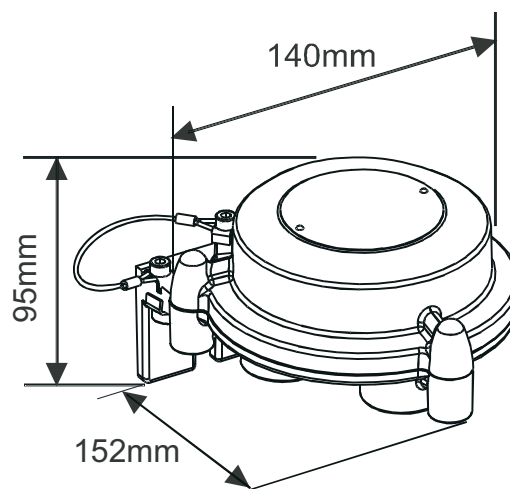
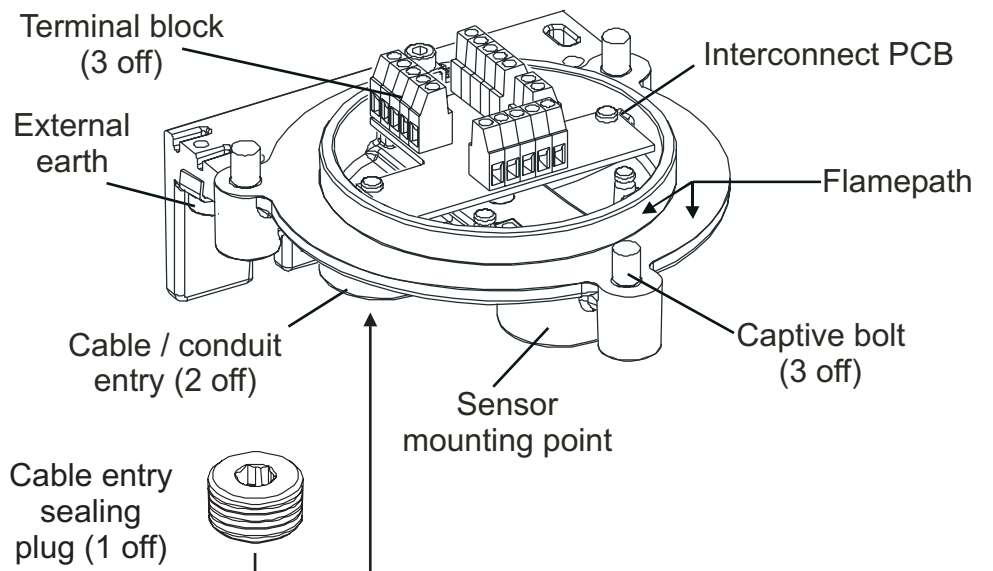
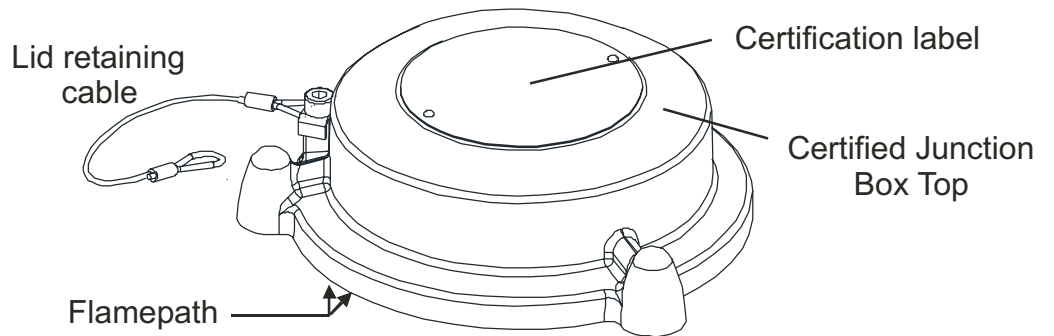

---

## 2. OVERVIEW

---

### 2.3.2 Collecting Cone

**Caution:** *This accessory should not be used for calibration purposes.*

**Part Number:** 2110B2151

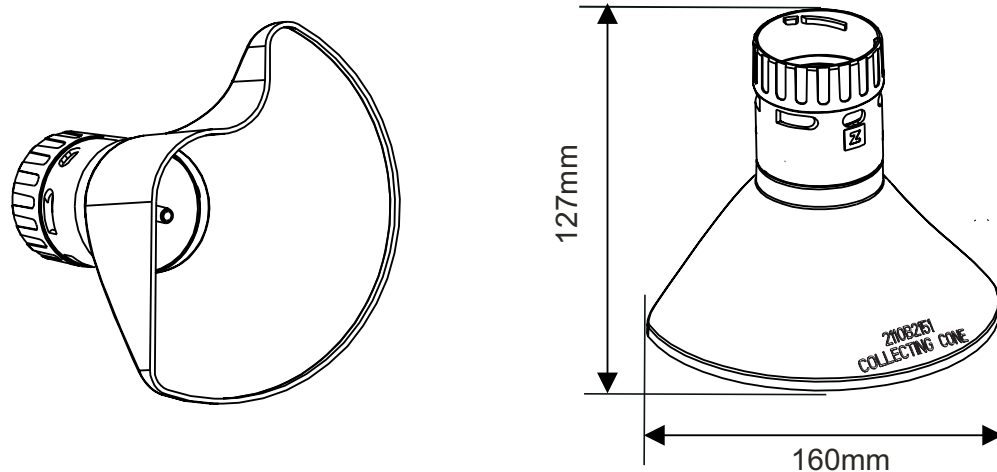

The Collecting Cone is **only** for use when monitoring lighter-than-air gases. Its shape is designed to:

- increase the collection area for lighter than air gases
- allow the gases to escape so that the time to clear an alarm is not excessively prolonged.
- fit against a wall or other flat surface

Conforms to **CSA C22.2 No. 152** when fitted to the Certified Sensor with specific cartridges installed. See specifications for details.

The performance of this accessory has not been evaluated to EN50054/57

The Collecting Cone is attached to the sensor by means of a bayonet fitting.

Inside the cone is a 1/4in. O/D nozzle that can accept a tube and which provides a means to directly inject gas to the front of the sensor for gas response checking. The recommended flow rate for response checks is 1 litre per minute.

Accuracy of reading is not guaranteed.

*Note: Do not carry out response checks at wind speeds greater than 10m/s (22mph).*



---

## 2. OVERVIEW

---

### 2.3.3 Flow Housing

**Part Number:**

**2110B2140**

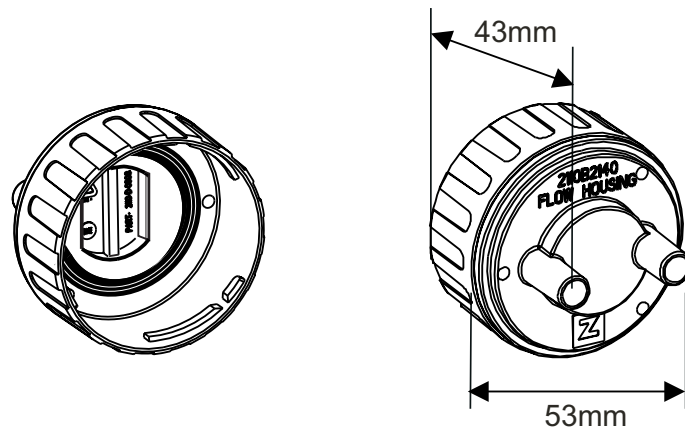

The Flow Housing accessory provides a means of applying gas to the sensor for calibration and test (for details see section 4.7). It can also be used in sampling systems where a sample of gas is drawn through a tube to the sensor. Conforms to **CSA C22.2 No. 152** when fitted to the Certified Sensor with specific cartridges installed. See specifications for details.

It provides:

- Two ports 8mm I/D to take 6mm tubing.
- A seal to stop gas dilution.

The housing works irrespective of which pipe the gas is applied to and flows gas across the face of the sensor rather than onto its face.

The difference in reading between a calibration made with the Flow Housing accessory and one made under diffusion conditions (in a tank of still gas) is less than 30%. The Flow Housing is suitable for flow rates in the range of 0.7 - 1 litre per minute flow across the cell.

A hydrophobic filter is supplied with the housing which **must** be used when calibrating sensors fitted with flammable gas cartridges.

When calibrating sensors fitted with other types of cartridge then the filter mounted in the sensor cap for normal gas sensing operation (if fitted) must be removed and used in the Flow Housing.

The Flow Housing accessory is attached to the sensor by means of a

---

## 2. OVERVIEW

---

bayonet fitting.

### 2.3.4 Weather Housing

**Caution:** *This accessory should not be used for calibration purposes.*

*This accessory is not recommended for use in still air conditions.*

**Part Number:**

**2110B2150**

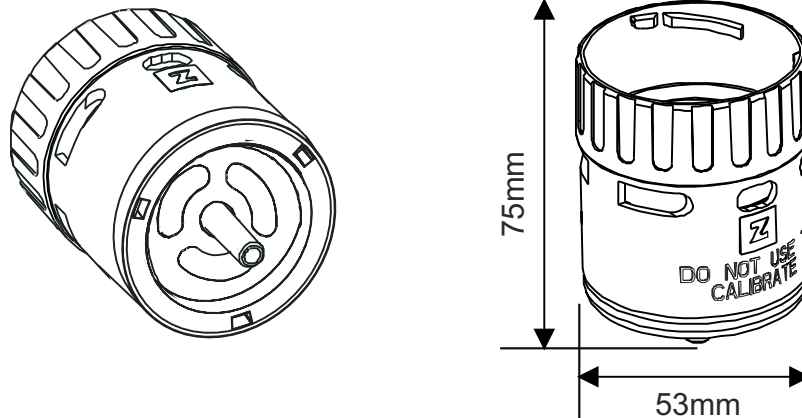

The Weather Housing accessory protects the sensor from hosing down/cleaning operations and from extreme weather conditions, (e.g. torrential rain, storms, gales etc.). Conforms to **CSA C22.2 No. 152** when fitted to the Certified Sensor with specific cartridges installed. See specifications for details.

The weather housing should not be fitted if the operating environment of the sensor does not require the additional protection afforded. In still air conditions the gas is transported to the face of the sinter is by diffusion only. Under such conditions the weather protection will slow the rate at which gas can reach the sensing element and consequently the speed of response of the sensor to gas will be reduced.

As well as providing weather protection the housing also provides a means to directly inject gas to the front of the sensor via a 1/4in. O/D nozzle for gas response checking. The recommended flow rate for response checks is 1 litre per minute. Accuracy of reading is not guaranteed. Do not carry out response checks at wind speeds greater than 10m/s (22mph).

The accessory is attached to the sensor by means of a bayonet fitting.

Note: The sensor will exhibit an increased reading(or indication) to gas with higher wind speeds. Fitting the weather housing with the supplied hydrophobic filter will eliminate this effect but increase the response time.

## 2. OVERVIEW

### 2.3.5 Sunshade

**Part Number:**

**2110B2152**

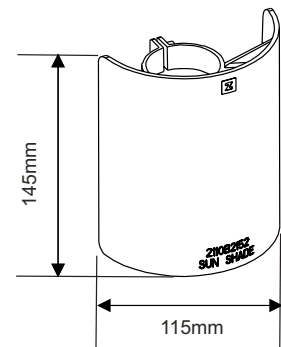
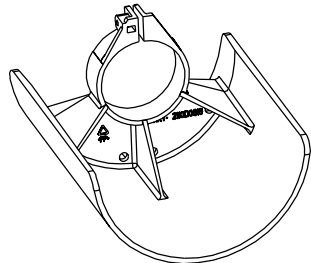

The Sunshade prevents excessive heating of the sensor by direct sunlight. Conforms to **CSA C22.2 No. 152** when fitted to the Certified Sensor with specific cartridges installed. See specifications for details.

The performance of this accessory has not been evaluated to EN50054/57.

The sunshade is fitted to the sensor body by means of a clamp.

### 2.3.6 Oxygen Transducer Adaptor

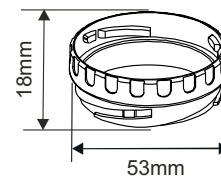

The Oxygen Transducer Adaptor is supplied with the Oxygen cartridge and is necessary because the depth of the Oxygen cartridge is more than that of the other gas cartridges.

The adaptor is attached to the Certified Sensor by means of a bayonet fitting. The Oxygen cartridge is fitted first and the sensor cap or accessory is then fitted to the adaptor by means of a bayonet fitting.

### 2.3.7 Filters

One of three different types of filter accessory can be fitted to the Certified Sensor in place of the rubber seal inside the sensor cap or accessory.

The three different types of filter available are:

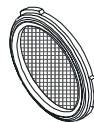

**Mesh filter - Part Number: 2110B2170** - for use in harsh environments. The filter prevents dirt from blocking the cartridge sinter.



**Hydrophobic filter - Part Number: 2110B2171** - for use in environments where the cartridge front is likely to become wet. The hydrophobic material allows gas to pass through but not water. A hydrophobic filter is supplied with the Flow Housing and **must** be used when calibrating sensors fitted with flammable gas cartridges.

**Caution: The sensitivity of some cartridges may be degraded by the hydrophobic filter.**

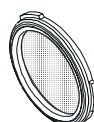

**Carbon filter - Part Number: 2110B2172** - for use in environments where significant volatile compounds are present. The filter prevents the cartridge from being critically affected.

The performance of this accessory has not been evaluated to EN500054/57

---

## 3. INSTALLATION

---

The Apex system components can be used together in a variety of ways for different installation requirements in a hazardous environment. For installations of certified components also refer to the Control Drawings in **Appendix B**.

The following types of system installation are *typical examples* of those that can be made:

- **Apex Transmitter unit with a Certified Sensor locally mounted at the Transmitter Unit and field wiring from the Transmitter Unit to the system controller.**
- **Transmitter unit with a Certified Sensor mounted remotely in a Certified Junction Box, with field wiring between the two components, and from the Transmitter Unit to the system controller.**

This chapter describes how to:

- **carry out the installation of a Transmitter Unit and Certified Sensor**
- **install an Certified Junction Box accessory with Certified Sensor, suitable for remote operation**
- **install a LonWorks Communications Board in a Transmitter Unit**

*This is to enable the unit to be controlled and communicate over a digital network, e.g. LonWorks.*

**Caution:** *Do not install a communications board into a UL or CSA certified Transmitter Unit as approval for fitment is pending.*

- **install the system accessories**

When fitting the system components consideration should be made regarding potential gas leak sources, density of the gas to be detected, probability of mechanical impacts and interference from other equipment and apparatus.

For optimum performance the Transmitter Unit and Certified Sensor should be installed in a location free from dust and direct sunlight. Sunshade and weather protection accessories for the sensor are available when operating in harsh external environments (see **3.4**).

Refer to the relevant control system manual for external network connection information (e.g. field wiring, etc.).

---

## 3. INSTALLATION

---

Also see drawing **2110C8049 Outline Dimensions of Certified Transmitter, Sensor & Accessories** (available on request from Zellweger Analytics).

### General Installation Guidelines

The following general points should be noted before any installation is carried out.

- **Read all the instructions before starting any of the installation procedures.**
- **Identify a suitable location with a flat surface where the Apex Transmitter Unit/Certified Junction Box can be mounted.**
- **Identify external cable requirements and the necessary cable/conduit entry ports to be used on the Apex Transmitter Unit/Certified Junction Box.**
- **The Certified Sensor must always point downwards to avoid collection of fluids and other materials on the face.**
- **When fitting components that are certified also refer to the Control Drawings (see *Appendix B*).**

The system components comply with the EMC requirements of EN50270. In order to maintain compliance with this standard it is essential that the components are installed correctly as detailed below. It is the responsibility of the installation design authority to ensure that the electrical installation meets appropriate standards.

1. The unit should not be electrically connected to electrically noisy (dirty) metalwork or conductors. The case should be connected to a low noise (clean) earth line via the screen on the field cabling.
2. The entire length of the field cabling connected to each unit should be fully screened with the screen connected to a low noise earth.
3. The low noise earth line should only be connected to safety earth at a single point. Star earthing arrangements minimise earth current crosstalk. Field cabling shields should not be connected such that earth loops are produced.
4. The earth bonding arrangement must ensure that the maximum peak voltage between the unit case earth and any field cable conductor is less than 350V. Voltages in excess of this can cause permanent damage to the unit's RFI protection filters.
5. The use of a single, screening cable for each gas detector ensures maximum screening and minimum crosstalk. Cabling arrangements which use a single cable for connecting field devices compromise screening, increase the

## 3. INSTALLATION

potential for crosstalk and prevent implementation of true star earthing.

6. Any electrical interference induced onto the 4-20mA loop conductors by the installation must be kept below the levels necessary to comply with the general requirements of EN50270. In practice, this means that peak noise currents induced on the current loop should be no greater than  $\pm 0.25\text{mA}$ .
7. The 0V rail of the control card/system is often directly connected to one side of the 4-20mA current sensing resistor. Electrical noise on such a rail is therefore directly connected to the 4-20mA input. In order to avoid additional noise being induced on the 0V rail, it should not be common with the safety earth/ground which frequently carries a high level of electrical noise.
8. The 24V supply should be free from large transients and fluctuations.

The type of cable used for field wiring between the Apex transmitter and control equipment, and between the Apex transmitter and Apex sensor if mounted remotely, should be selected to meet the environmental and hazardous area requirements. The cable internal construction should be a of the screened, multi-core, multi-stranded type. The terminals within the product will accept a maximum conductor size of  $2.5\text{mm}^2$  (14AWG). The recommended minimum conductor size is  $0.75\text{mm}^2$  (20AWG). The conductors should be sized to give a total power supply loop resistance of less than 30 Ohms (ECC cartridge) or 16 Ohms (Catalytic cartridge). If remote mounting the sensor from the transmitter a 4-core, screened cable with a minimum conductor size of  $0.75\text{mm}^2$  (20AWG) is required.

### 3.1 TRANSMITTER UNIT AND CERTIFIED SENSOR

This installation consists of a Transmitter Unit with Certified Sensor locally mounted at the Transmitter Unit together with field wiring.

Apex Transmitter Unit  
with Certified Sensor  
(North America-style  
installation)

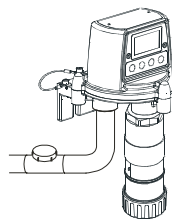

Apex Transmitter Unit  
with Certified Sensor  
(European-style  
installation)

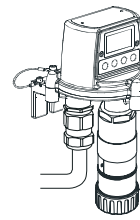

The system components can be installed by a single technician.

This procedure describes how to:

- **install a Transmitter Unit**
- **fit a Certified Sensor to the local Transmitter Unit**
- **connect up the Certified Sensor and field wiring**
- **configure the Transmitter Unit relay and alarm settings**
- **install a gas sensing cartridge into the Certified Sensor**

## 3. INSTALLATION

Refer to the **General Installation Guidelines** at the beginning of this chapter.

### 3.1.1 Installing the Transmitter Unit

Cautions:

1.  **Observe precautions for handling electrostatic discharge sensitive devices.**
  2. **Ensure that the Apex Transmitter Unit flamepath is not damaged during this procedure. The flamepath is formed by the mating surfaces of the Apex Transmitter Unit top and base (see diagram).**
- (1) Isolate all associated power supplies and ensure that they remain **OFF** during the installation procedure. Ensure a gas free atmosphere.
- (2) Attach the Apex Transmitter Unit to the supporting structure.  
*Drill two mounting holes (68mm apart) and use the unit's mounting slots in the base with either two M10 bolts or a single 10mm U-bolt.*

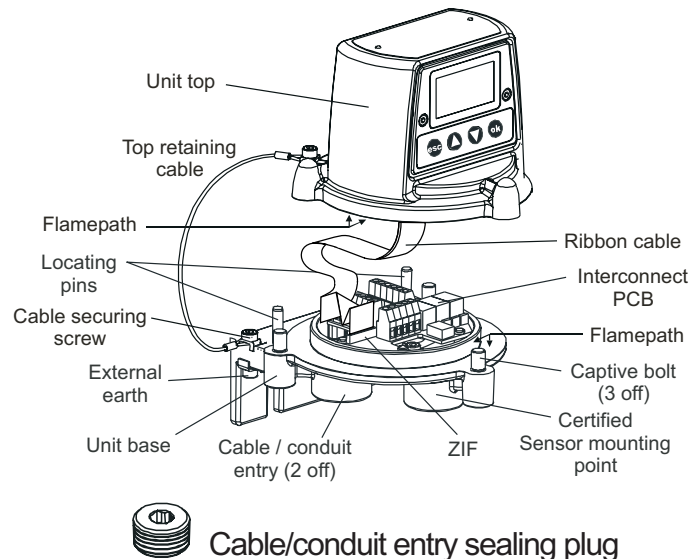

- (3) Detach the top of the Transmitter Unit.  
*Unscrew the three captive M8 bolts in the base. Support the top and let the metal retaining cable, attaching the top to the base, hold the top. Take care not to damage or strain the ribbon cable between the top and the base.*
- (4) Fit and connect the field wiring.  
*See the subsequent wiring table and diagram. Use either:*



## 3. INSTALLATION

**Conduit** - using one or both of the 3/4 NPT conduit entries. Ensure that a conduit sealing fitting is installed within 460mm of the enclosure on all conduit runs.

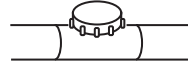

**Cable** - using any suitable flameproof cable entry device certified as Equipment to Directive 94/9/EC (ATEX).

*Note:* All unused cable/conduit entries must be sealed with a suitable certified sealing plug (one plug is supplied).

Typical wiring arrangements to the Transmitter Unit are (with all cables screened):

### Single cable/conduit entry

Power	4-20mA	Digital Comms	Relays	Cores used
2	1	-	-	3
2	2	-	-	4
2	2	-	6	10
2	2	2	-	6
2	-	2	-	4

### Twin cable/conduit entries

Power	4-20mA	Digital Comms	Relays
2	2 (4 cores)	-	6 (6 cores)
2	2	2 (6 cores)	6 (6 cores)
2 x power in	-	2 x comms in (4 cores)	-
2 x power out	-	2 x comms out (4 cores)	-

More complex wiring schemes may need to use external Certified Junction Boxes either because of cable/conduit entry capacity or because there are more than two cable/conduit destinations.

### 3.1.2 Fitting the Certified Sensor

- (1) Fit the Certified Sensor to the Transmitter Unit.



### 3. INSTALLATION

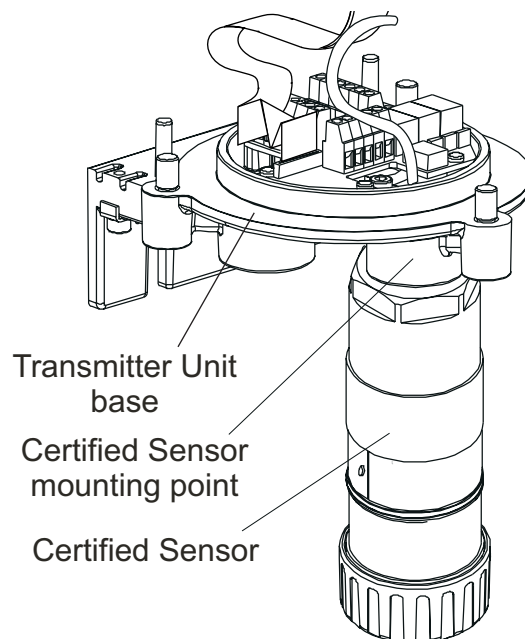

*Feed the sensor cable through the Certified Sensor mounting point at the front of the Transmitter Unit base. Screw the sensor firmly into the mounting point until it is fully home.*

- (2) Connect the sensor wiring.

*See the following wiring table and diagram.*

Terminal Number	Function	Colour	Recommended Wire Length	
<b>SK3</b> (Sensor)	1	CAN_L	White	40mm
	2	CAN_H	Green	40mm
	3	+V	Red	40mm
	4	0V	Black	40mm
	5	Screen		40mm
<b>SK4</b> (Comms and Power)	1	NET1		60mm
	2	NET2		60mm
	3	Ground		50mm
	4	4 - 20mA -		50mm
	5	4 - 20mA +		50mm
	6	0V		50mm
	7	+24Vdc (18-32Vdc)		50mm
<b>SK6</b> (Relays)	1	Fault		50mm
	2	Fault common		50mm
	3	Alarm 1		50mm
	4	Alarm 1 common		50mm
	5	Alarm 2		50mm
	6	Alarm 2 common		50mm
<b>G</b>	-	Earth	Green/Yellow	

## 3. INSTALLATION

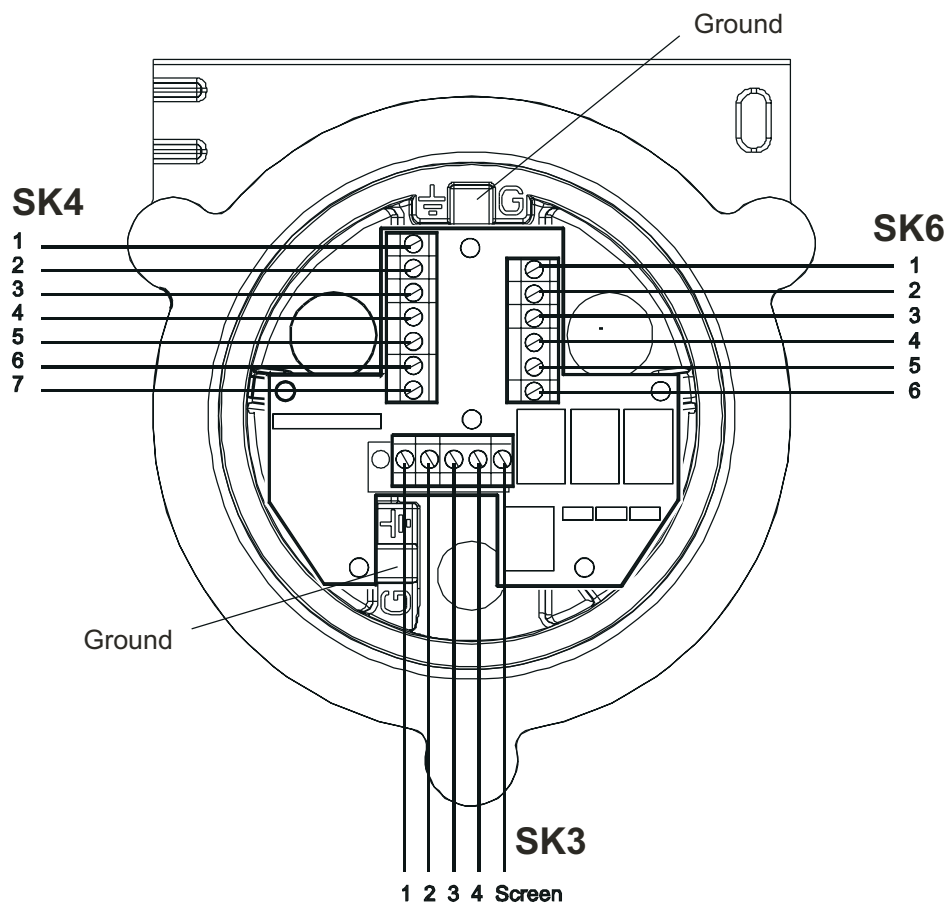

- (3) Configure the Transmitter Unit if required.

*Set the links on the Interconnect PCB for the required relay contact settings and for the 4-20mA topology. See 3.1.4.*

- (4) Refit the top to the base.

**Cautions:**

- 1. Ensure that there is no moisture inside the unit before fitting the top.**
- 2. Use only the captive bolts supplied, replacement with alternative bolts will invalidate certification.**

*Follow the reverse of the removal procedure supporting the top. The top should be positioned using the locating pins on the Apex Transmitter Unit base and then lowered onto the base.*

*Ensure that the lid retaining cable and wiring is not trapped and the O-ring in the top is correctly located.*

*Ensure that the ribbon cable is not twisted and is correctly positioned. Check that there is no discernible gap between the top and the base. Tighten the three captive M8 bolts to 5Nm (3.68 foot-pounds).*

## 3. INSTALLATION

### 3.1.3 Installing the Gas Sensing Cartridge

- (1) Remove the cap from the Certified Sensor body.

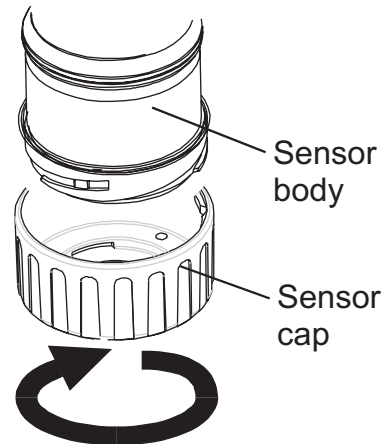

*Rotate the cap or accessory 1/4 turn in an anticlockwise direction to release the bayonet fitting.*

- (2) Fit the gas sensing cartridge into the sensor body.



#### **WARNING**

Sensor Cartridges may contain corrosive solutions. Dispose of according to local and national regulations.

*Each cartridge is provided with a certificate of calibration (printed on the reverse of the instruction sheet, Part No: 2110M8015, supplied with the cartridge) that guarantees that the cartridge is calibrated and ready for use. Before installing a cartridge check that the number on the cartridge label matches the gas type and range for the function required.*

**Caution: Only cartridges with the following part numbers can be fitted to the Certified Sensor:**

**2110B30x0, 31x0, 32x0, 33x0, 34x0 series**

**2110B3700 - 2110B3999 range**

**Note:** Conforms to **CSA C22.2 No. 152** only when fitted with specific cartridges. See specifications for details.

*Carefully plug the cartridge into the Certified Sensor body ensuring that the cartridge tab lines up with the recess in the sensor body and push the cartridge, without twisting, until it is fully home.*

*If the cartridge will not push fully home, re-check that the locating tab is correctly aligned with the recess in the sensor body. Position the tab so it is resting on the tab recess wall to the right or left of the tab recess and then turn the cartridge until the tab drops into the recess.*

## 3. INSTALLATION

**Caution:** *Do not force the cartridge as this may cause damage to the pins of the connecting plugs. Twisting and pushing can bend the pins and make the cartridge inoperative.*

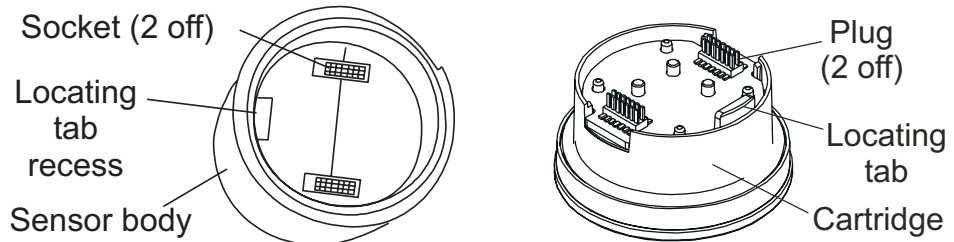

**Note:** *If fitting an Oxygen cartridge ensure that the Oxygen Transducer Adaptor supplied with the Oxygen cartridge is fitted to the Certified Sensor body. The adaptor is fitted to the sensor body via a bayonet fitting.*

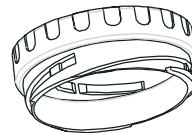

- (3) Refit the cap to the Certified Sensor.

*Reverse the removal procedure.*

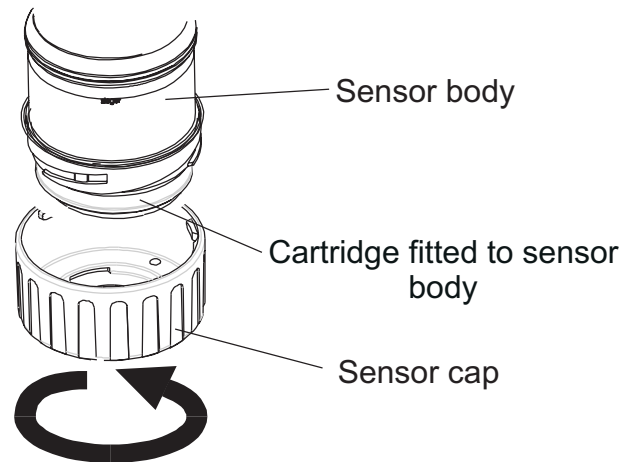

- (4) Check for correct operation of the system by carrying out the procedures described in **Chapter 4**.

# 3. INSTALLATION

## 3.1.4 Transmitter Unit Configuration

**Caution:** Do not change either Relay or 4-20mA link setting while unit is powered up.

The following information specifies the unit configuration options.

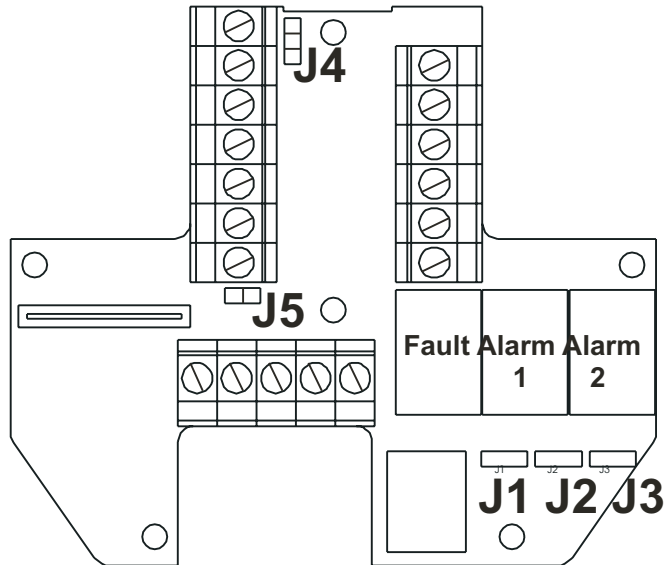

### Relays

Links J1, J2 and J3 set the contact operation for the **Fault**, **Alarm 1** and **Alarm 2** relays respectively.

#### J1 (Fault relay)

 Normally open.  
(default)

 Normally closed

#### J2 and J3 (Alarm 1 and 2 Relays)

 Normally open (default)

 Normally closed

**Note:** Relay contacts are rated at 100mA (min), 2A (max), 30Vdc non-inductive\*. **HIGHER VOLTAGES MUST NOT BE USED**  
(\* UL specification: 28Vdc, 1A)

# 3. INSTALLATION

## 4-20mA loop

The summary table and subsequent diagrams identify the link and terminal settings for 4-20mA loop options.

Link	SK4 Terminal	4 - 20mA loop topology		
		Isolated	Source	Sink
J4	-			
J5	-			
-	<b>4</b>	4 - 20mA -	4 - 20mA -	not used
-	<b>5</b>	4 - 20mA +	not used	4 - 20mA +

*Note: Total 4-20mA loop resistance should be less than 300 ohms.  
Total power supply loop resistance should be less than 30 ohms (ECC cartridge) or 16 ohms (catalytic cartridge).  
Typical power consumption with relays active is 3.6W (ECC cartridge) or 5.6W (catalytic cartridge).*

### Isolated Mode (4-wire)

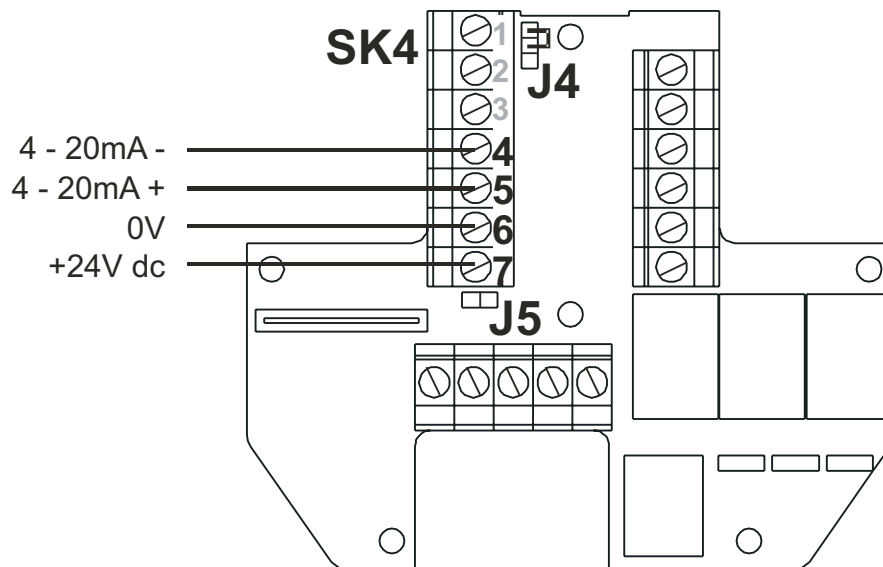

# 3. INSTALLATION

## *Current Sink Mode (3-wire)*

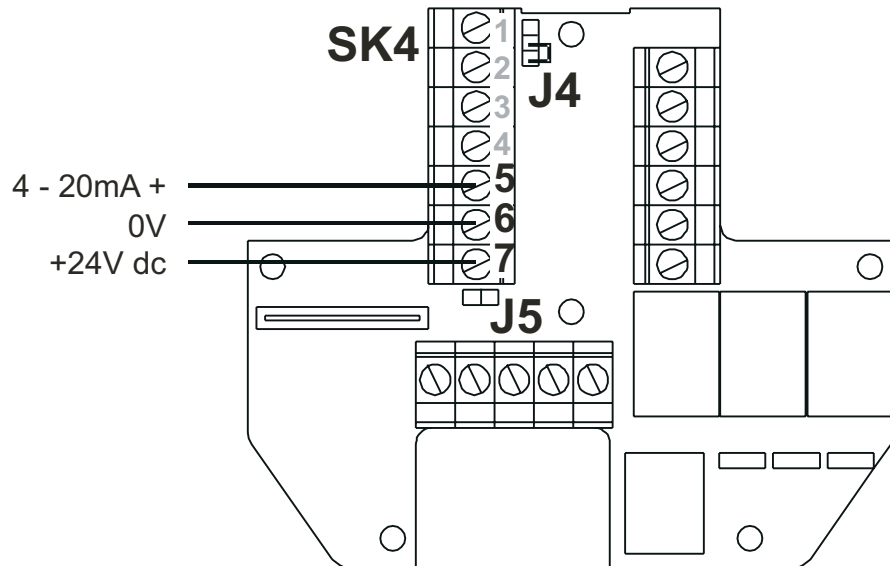

## *Current Source Mode (3-wire)*

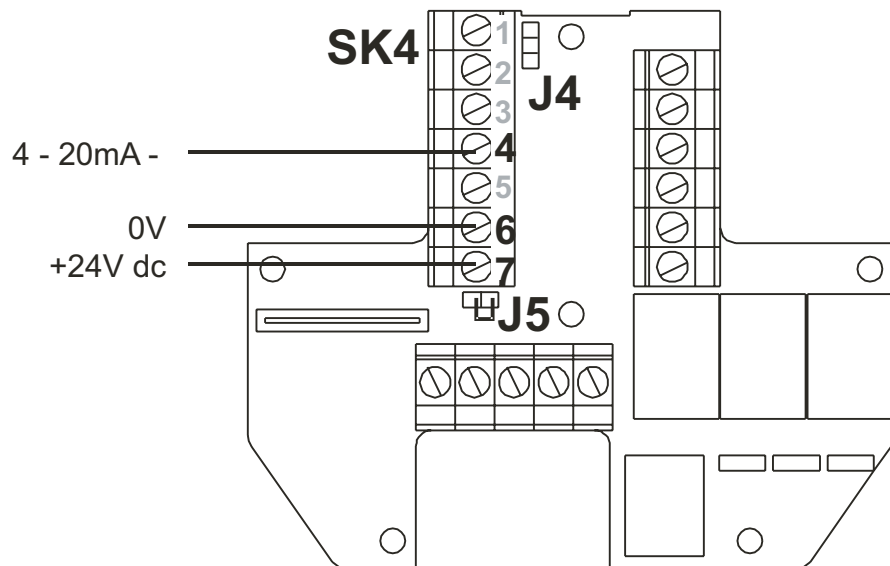

## 3.2 CERTIFIED JUNCTION BOX AND CERTIFIED SENSOR

This installation consists of a Certified Junction Box accessory with the Certified Sensor locally mounted at the box together with field wiring.

---

## 3. INSTALLATION

---

### Apex Transmitter Unit with Certified Sensor mounted in Certified Junction Box (North America-style installation)

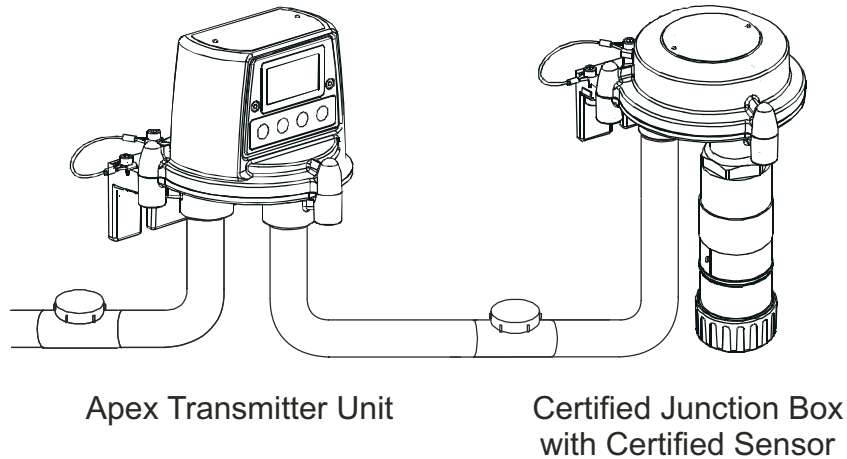

### Apex Transmitter Unit with Certified Sensor mounted in Certified Junction Box (European-style installation)

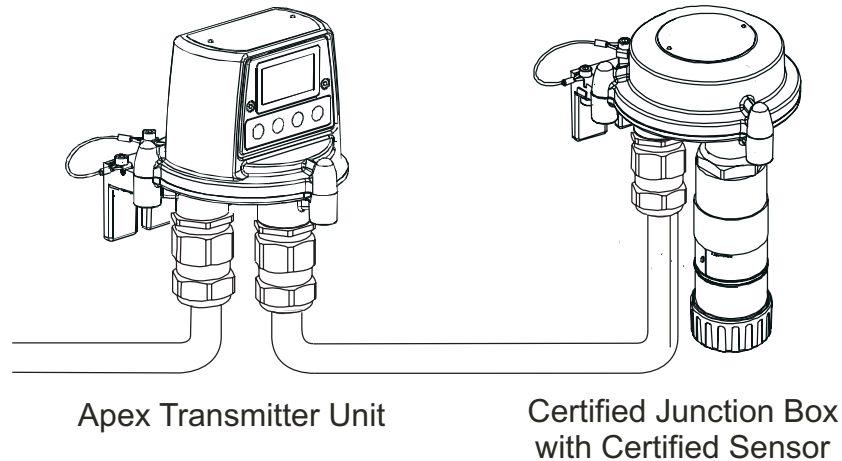

The system components can be installed by a single technician. This procedure describes how to:

- **install a Certified Junction Box**
- **fit the Certified Sensor to the Certified Junction Box**
- **connect up the Certified Sensor and field wiring**
- **configure the Certified Junction Box**
- **install a gas sensing cartridge into the Certified Sensor**

Refer to the **General Installation Guidelines** at the beginning of this chapter.



## 3. INSTALLATION

### 3.2.1 Installing the Certified Junction Box

**Caution:** *Ensure that the Certified Junction Box flamepath is not damaged during this procedure. The flamepath is formed by the mating surfaces of the Certified Junction Box top and base (see diagrams).*

- (1) Isolate all associated power supplies and ensure that they remain **OFF** during the installation procedure. Ensure a gas free atmosphere.

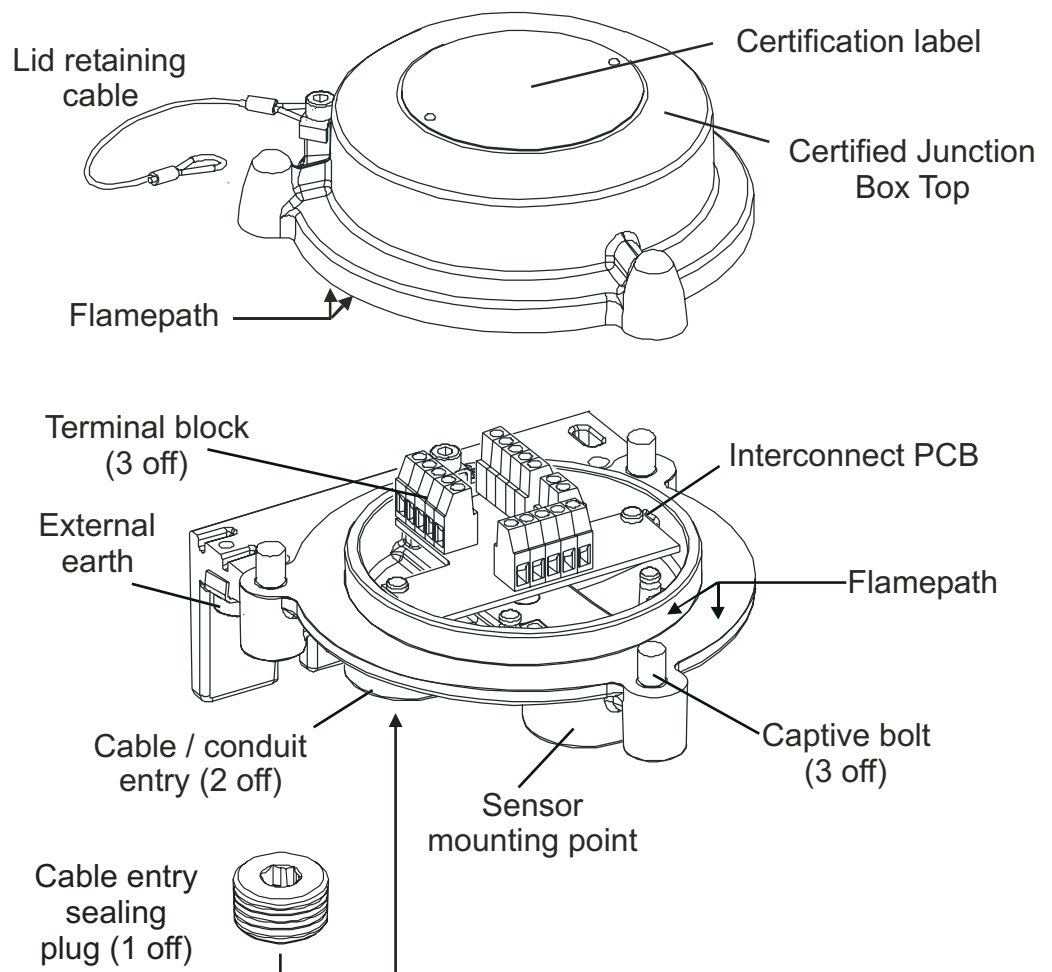

- (2) Attach the Certified Junction Box to the supporting structure.  
*Drill two mounting holes (68mm apart) and use the unit's mounting slots in the base with either two M10 bolts or a single 10mm U-bolt.*
- (3) Remove the Certified Junction Box lid.  
*Unscrew the three captive M8 bolts. The lid is retained by a metal retaining cable attached to the base.*
- (4) Fit and connect the field wiring.  
*See the subsequent tables and diagram for wiring details. Use either:*

## 3. INSTALLATION

**Conduit** - using one or both of the  $f$  NPT conduit entries. Ensure that a conduit sealing fitting is installed within 18" of the enclosure on all conduit runs.

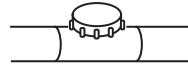

**Cable** - using any suitable flameproof cable entry device certified as Equipment to Directive 94/9/EC (ATEX).

Notes:

1. All unused cable/conduit entries must be sealed with a certified sealing plug (one plug is supplied fitted).
2. For a multi-sensor system using a network loop, both cable/conduit entries are used, one bringing the loop connections in and the other taking them out of the box. Remove the fitted certified sealing plug from the spare cable/conduit entry.

### 3.2.2 Fitting the Certified Sensor

- (1) Fit the Certified Sensor to the Certified Junction Box.

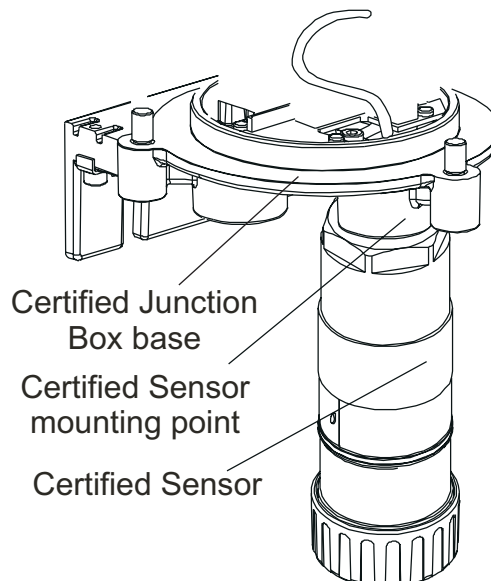

Pass the sensor connecting cable through the sensor mounting point and then screw the sensor firmly into the sensor mounting point until it is fully home.

- (2) Connect the sensor wiring.

See the following diagram and table for wiring details.

## 3. INSTALLATION

Terminal/Number	Function	Colour	
<b>SK1</b>	1	CAN_L	White
<b>SK2</b>	2	CAN_H	Green or Blue
<b>SK3</b>	3	+V	Red
	4	0V	Black
	5	Not used	-
<b>SK4</b>	1	Screen *	-
	2	Screen *	-
<b>G</b>	-	Earth	Green/Yellow

\* Only connect cable screens to these terminals if they are isolated at the remote end.

*Note: Three sensor wiring terminal blocks are provided (SK1, SK2 SK3), any two can be used.*

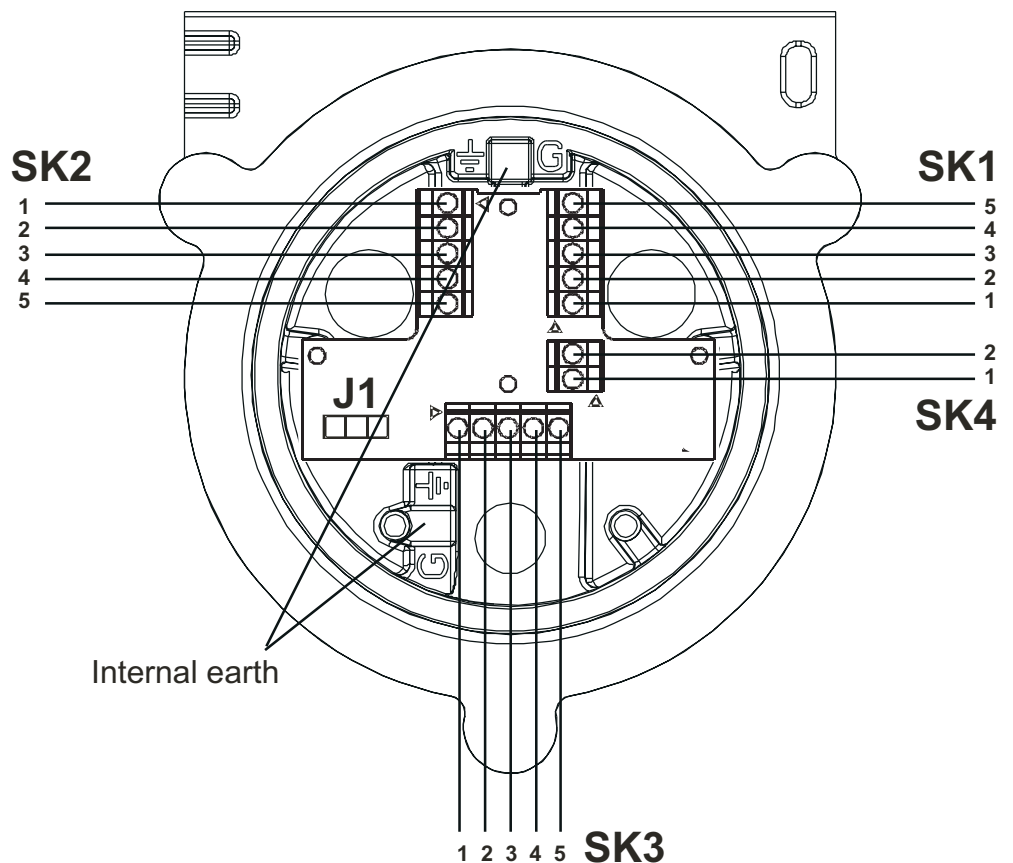

- (3) Configure the Certified Junction Box if required.  
*Set the link on the Interconnect PCB for the required Controller Area network (CAN) setting. See 3.2.4.*
- (4) Refit the top to the Certified Junction Box base.

## 3. INSTALLATION

### Cautions:

1. **Ensure that there is no moisture inside the Certified Junction Box before fitting the lid.**
2. **Use only the captive bolts supplied, replacement with alternative bolts will invalidate certification.**

*The top should be located using the locating pins on the Certified Junction Box base and then lowered onto the base. Ensure that the lid retaining cable and/or wiring are not trapped and the O-ring in the top is correctly located. Check that there is no discernible gap between the top and the base. Tighten the captive M8 bolts to 5Nm (3.68 foot-pounds).*

### 3.2.3 Installing the Gas Sensing Cartridge

- (1) Remove the cap from the Certified Sensor body.

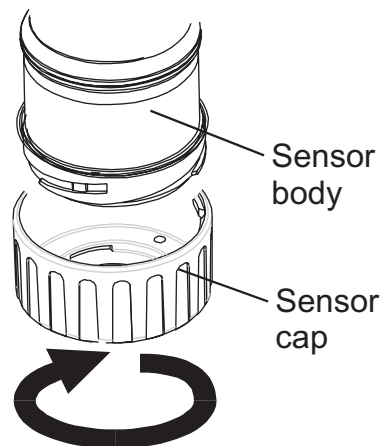

*Rotate the cap or accessory 1/4 turn in an anticlockwise direction to release the bayonet fitting.*

- (2) Fit the gas sensing cartridge into the sensor body.



### WARNING

Sensor Cartridges may contain corrosive solutions.  
Dispose of according to local and national regulations.

*Each cartridge is provided with a certificate of calibration (printed on the reverse of the instruction sheet, Part No: 2110M8015, supplied with the cartridge) that guarantees that the cartridge is calibrated and ready for use. Before installing a cartridge check that the number on the cartridge label matches the gas type and range for the function required.*

**Caution: Only cartridges with the following part numbers can be fitted to the Certified Sensor:**

**2110B30x0, 31x0, 32x0, 33x0, 34x0 series  
2110B3700 - 2110B3999 range**

### 3. INSTALLATION

**Note:** For remote CSA Certified Sensor installations combustible cartridges in the range of part numbers **2110B3700** to **2110B3799** **MUST NOT BE FITTED**.

Carefully plug the cartridge into the Certified Sensor body ensuring that the cartridge tab lines up with the recess in the sensor body and push the cartridge, without twisting, until it is fully home.

If the cartridge will not push fully home, re-check that the locating tab is correctly aligned with the recess in the sensor body. Position the tab so it is resting on the tab recess wall to the right or left of the tab recess and then turn the cartridge until the tab drops into the recess.

**Caution:** Do not force the cartridge as this may cause damage to the pins of the connecting plugs. Twisting and pushing can bend the pins and make the cartridge inoperative.

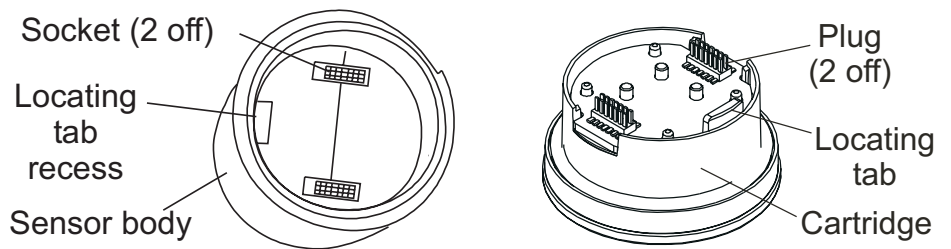

**Note:** If fitting an Oxygen cartridge ensure that the Oxygen Transducer Adaptor supplied with the Oxygen cartridge is fitted to the Certified Sensor body. The adaptor is fitted to the sensor body via a bayonet fitting.

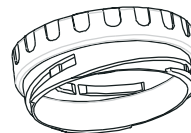

(3) Refit the cap to the Certified Sensor.

Reverse the removal procedure.

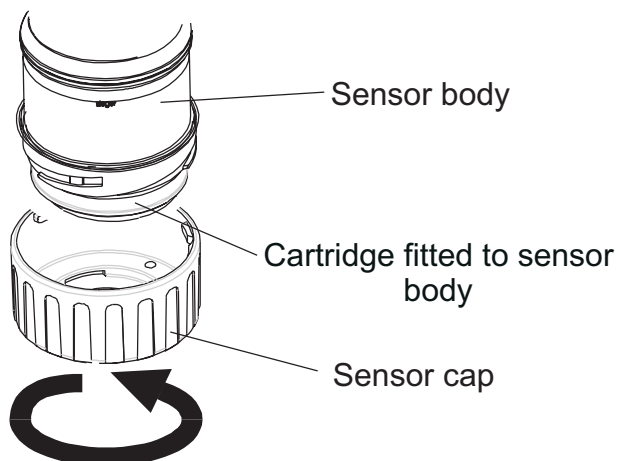

## 3. INSTALLATION

- (5) Check for correct operation of the system by carrying out the procedures described in **Chapter 4**.

### 3.2.4 Certified Junction Box Configuration

The following information specifies the Certified Junction Box configuration options.

#### Controller Area Network (CAN) Termination Link - J1

- Terminated
- Unterminated (default)

*Note:* Leave the link in the **Unterminated** position.

### 3.3 LONWORKS COMMUNICATIONS BOARD

The LonWorks Communications Board can be installed in the Transmitter Unit by a single person. It is fitted into the top of the unit to form part of the Main PCB assembly.

*Note:* Do not install a communications board into a UL or CSA certified Transmitter Unit as approval for fitment is pending.

Refer to the **General Installation Guidelines** at the beginning of this chapter.

Fitting the board should be carried out by a qualified technician.

Electrical interconnections for the communications board are made at the same time as mechanical installation by means of plugs attached to the communications board. These plugs mate with existing sockets on the main PCB fitted to the Apex Transmitter Unit lid.

Once the board is fitted any external LonWorks network wiring required is connected.

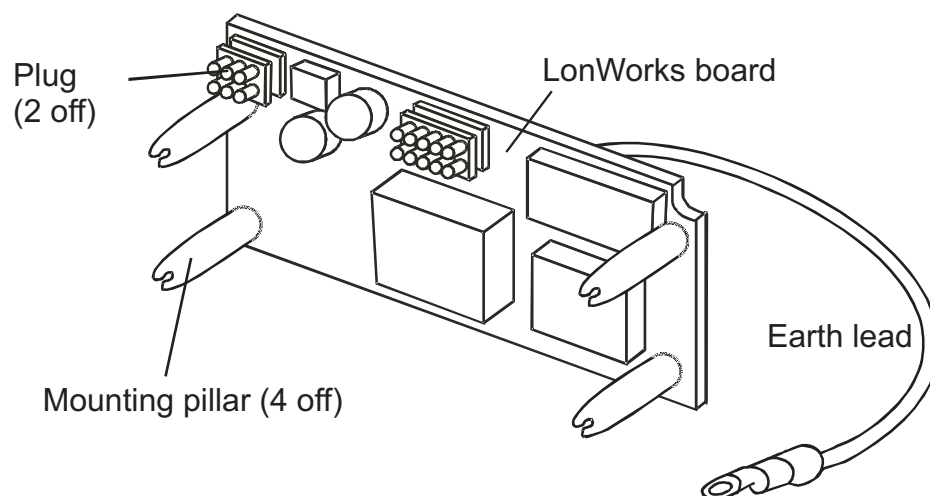

---

## 3. INSTALLATION

---

*Note: The board is supplied with the mounting pillars fitted to it.*

This procedure describes how to:

- **remove the Transmitter Unit top**
- **remove the Main PCB assembly from the top**
- **fit the LonWorks Communication Board to the Main PCB**
- **refit the Main PCB assembly into the top**
- **connect the LonWorks network wiring**
- **refit the Transmitter Unit top**
- **operational check and binding the LonWorks Communication Board to the network**

Refer to the **General Installation Guidelines** at the beginning of this chapter.

### 3.3.1 Removing the Transmitter Unit top

**Cautions:**

1.  **Observe precautions for handling electrostatic discharge sensitive devices.**
2. **Ensure that the Apex Transmitter Unit flamepath is not damaged during this procedure. The flamepath is formed by the mating surfaces of the Apex Transmitter Unit top and base (see diagram).**
  - (1) Isolate all associated power supplies and ensure that they remain **OFF** during this procedure. Ensure a gas free atmosphere.
  - (2) Disconnect from the Transmitter Unit base the wire retaining cable fitted between the top and the base.  
*Unscrew and remove the single M6 hexagon screw that secures the cable to the base.*

## 3. INSTALLATION

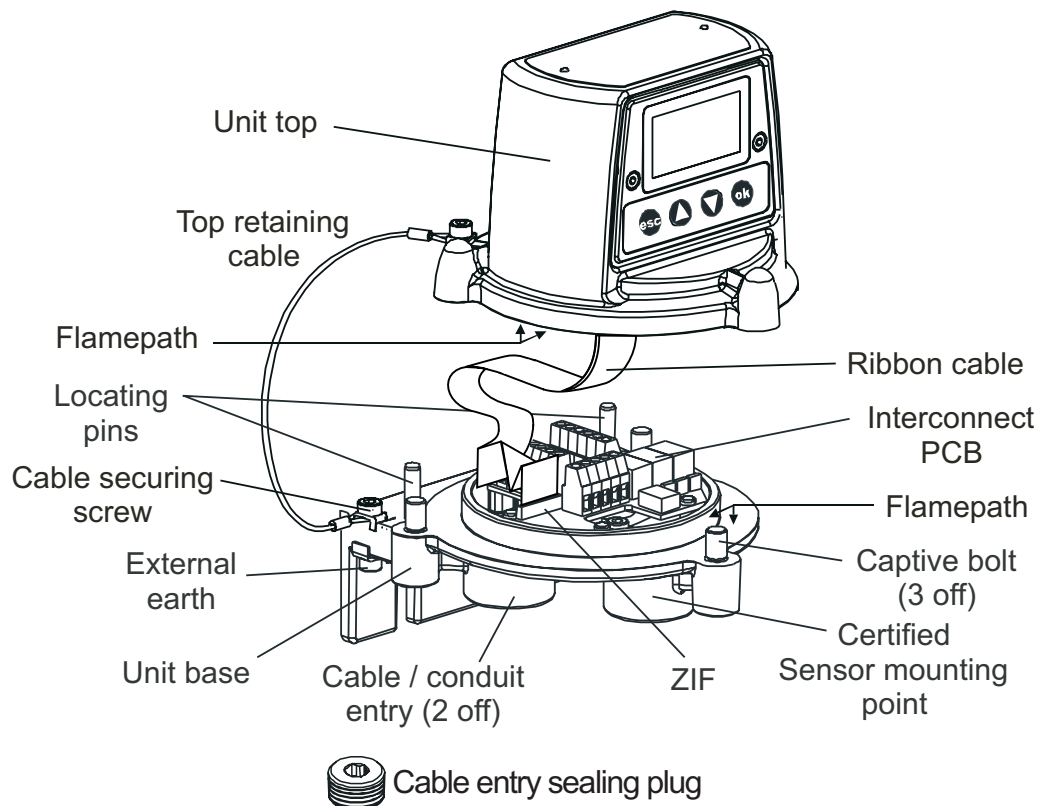

- (3) Detach the top of the Transmitter Unit.  
*Unscrew the three captive M8 bolts underneath the base. Lift the top clear of the locating pins. Take care not to damage or strain the ribbon cable connecting the top and the base. Support the top and ensure that it is supported whilst the next step is carried out.*
- (4) Unlatch the ribbon cable Zero Insertion Force (ZIF) connector on the Interconnect PCB.  
*Grip the ends of the ZIF and pull it vertically upwards until it is felt to stop and the ribbon cable is loose.*
- (5) Pull the ribbon cable clear.  
*Remove the top and take to a workshop area.*

### 3.3.2 Removing the Main PCB assembly from the top

- (1) Place the top with the certificate face down on a flat surface.  
*This provides access to the components inside the top.*



## 3. INSTALLATION

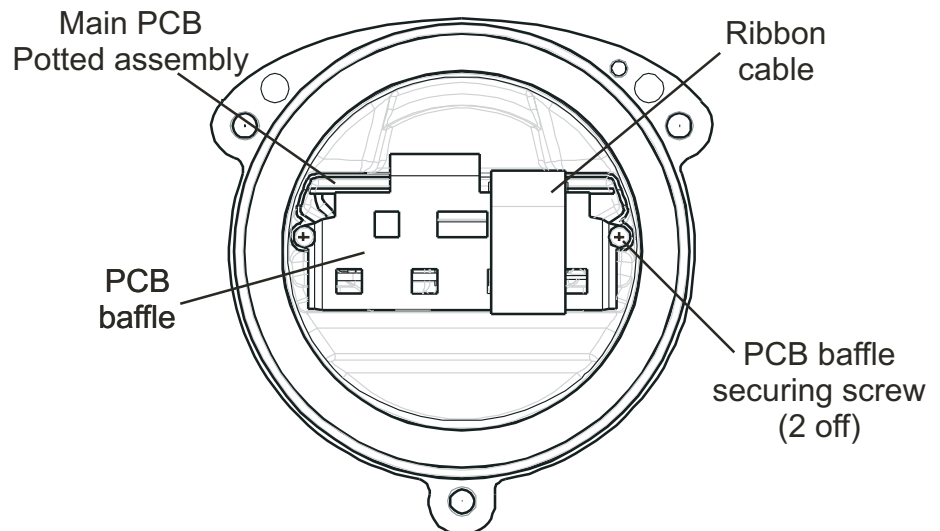

- (2) Remove the PCB Baffle from the Transmitter Unit top.  
*Unscrew and remove the two PCB Baffle securing screws.*
- (3) Disconnect the flying lead plug and socket connecting the Main PCB Potted assembly to the top.
- (4) Slide the Main PCB Potted assembly out of the Apex Transmitter Unit top.

### 3.3.3 Fitting the LonWorks Communication Board to the Main PCB

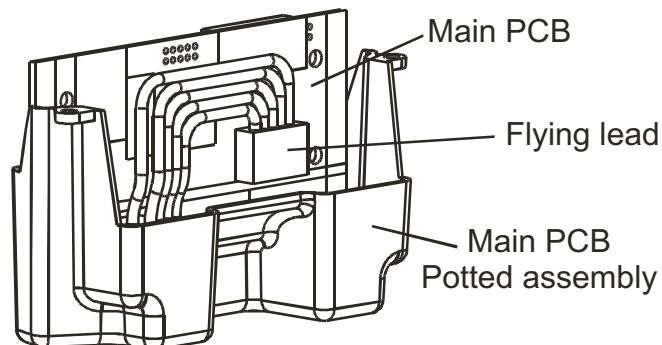

- (1) Place the Main PCB Potted assembly on a flat surface with the flying lead and plug on top.  
*Push the flying lead to one side so that there is clear access to the Main PCB.*
- (2) Remove the LonWorks Communication Board from its antistatic bag.
- (3) Position the Communication Board over the Main PCB.  
*Ensure the mounting pillars point downwards. Check that the two plugs on the Communication Board are correctly aligned with the sockets on the Main PCB and the mounting pillars are aligned with their mounting holes.*
- (4) Carefully press the Communication Board down evenly onto the Main PCB.

## 3. INSTALLATION

*Ensure that the pillars locate in their mounting holes and the electrical plugs are fully home.*

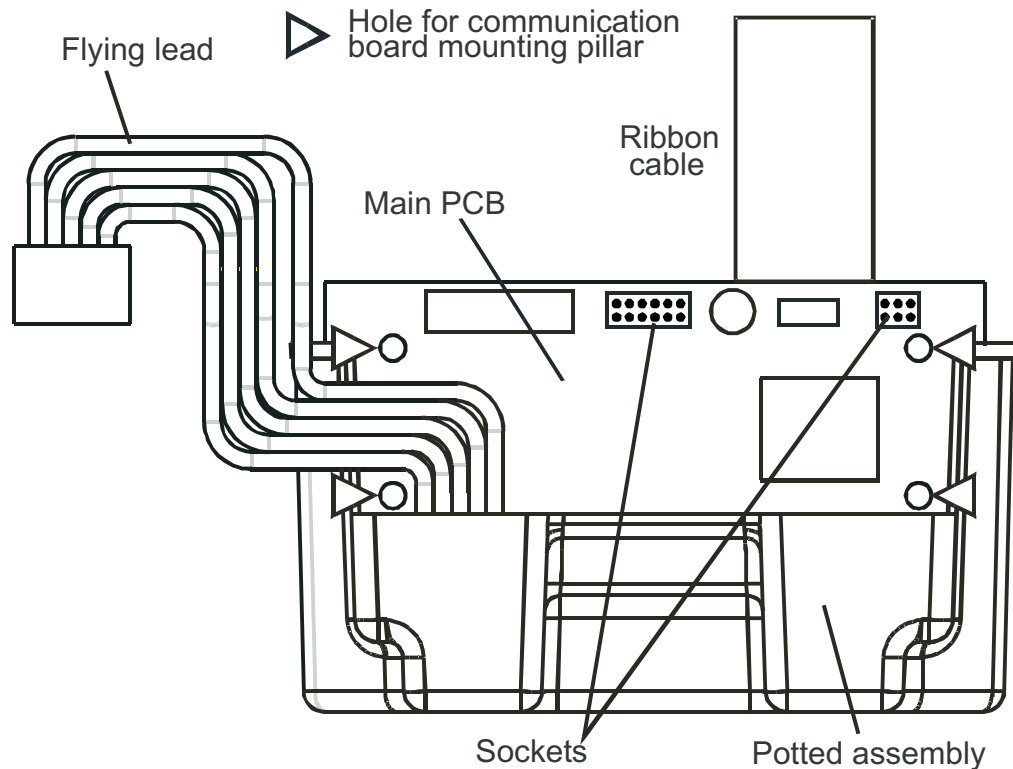

- (5) Reconnect the flying lead plug and socket connecting the Main PCB to the top.

### 3.3.4 Refitting the Main PCB Assembly into the Top

- (1) Refit the Main PCB Potted assembly with Communication Board into the top.

*Reverse the removal procedure. The assembly should be fitted so that the communications board is on the same side as the LCD display with the ribbon cable at the top.*

- (2) Refit the PCB Baffle.

**Caution:** *When refitting the parts into the top take care not to damage the flying lead plug assembly wires.*

*Ensure that the vertical part of the baffle goes between the Main PCB and the flying lead (see diagram).*

*Push the Communication Board earth lead through the top middle hole in the baffle.*

*Secure the earth lead under one of the two baffle securing screws. Tighten the screws to 1.0Nm (0.74 foot-pounds).*

## 3. INSTALLATION

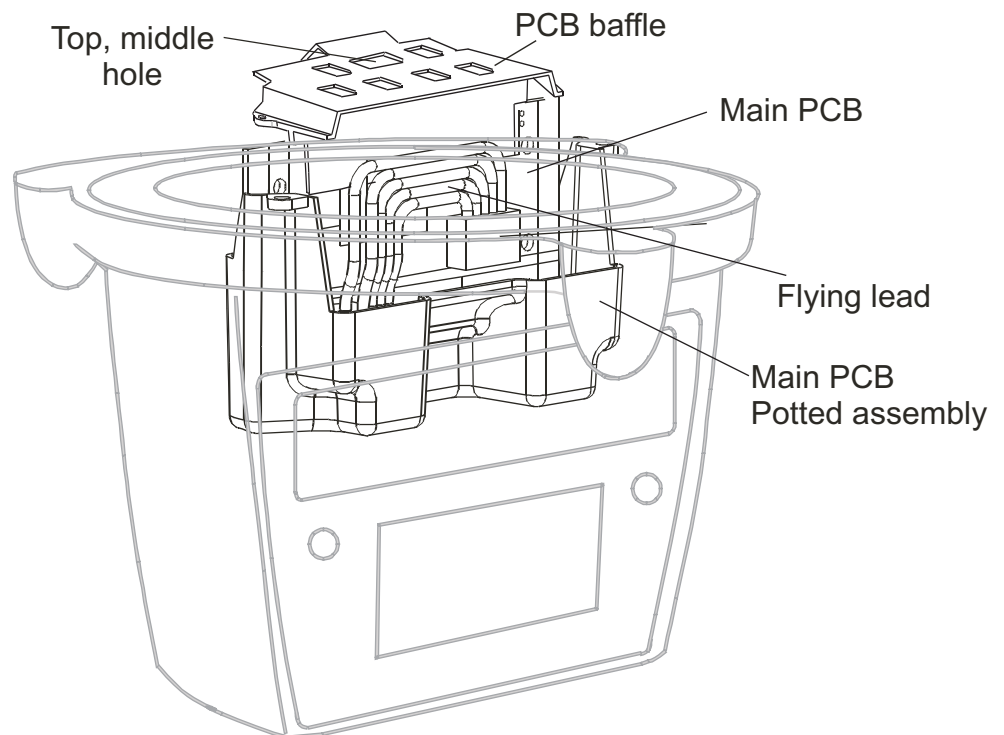

### 3.3.5 Connecting the LonWorks Network Wiring

- (1) Fit and connect the communication network field wiring to **SK4** in the base of the Transmitter Unit.

*Refer to the table and diagram for wiring details. Use either:*

**Conduit** - using one or both of the 3/4 NPT conduit entries. Ensure that a conduit sealing fitting is installed within 18" of the enclosure on all conduit runs.



**Cable** - using any suitable flameproof cable entry device certified as Equipment to Directive 94/9/EC (ATEX).

*Note: All unused cable/conduit entries must be sealed with a suitable certified sealing plug (one plug is supplied with the Apex Transmitter Unit).*

Terminal number	Function	Min. length of cable from entry point	
<b>SK4</b> (Comms & Power)	1	NET1	60mm
	2	NET2	60mm
	3	Ground	60mm

## 3. INSTALLATION

*Note: Three terminal blocks are provided, any two can be used.*

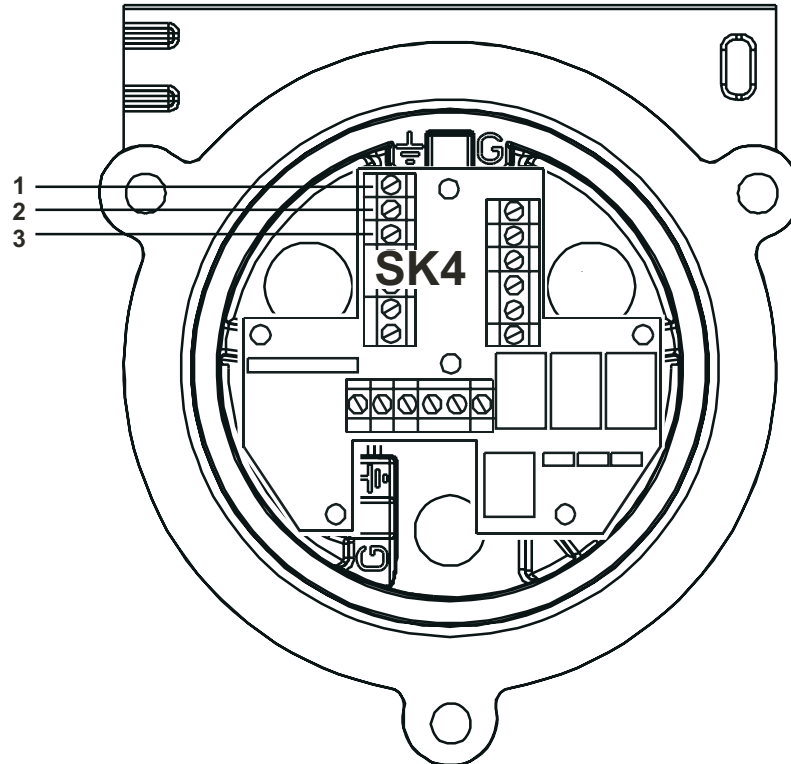

### 3.3.6 Refitting the Transmitter Unit Top

- (1) Support the top.

*Ensure that it is supported whilst the next step is carried out.*

- (2) Reconnect to the Transmitter Unit base the wire retaining cable fitted between the top and the base.

*Fit and tighten the single M6 hexagon screw that secures the cable to the base. Tighten the M6 screw to 3Nm (2.21 foot-pounds). Remove the support for the top and let the top down gently until it is supported by the retaining cable.*

- (3) Reconnect the ribbon cable into the ZIF connector on the Interconnect PCB in the base of the Transmitter Unit.

*Follow the reverse of the removal procedure ensuring that the ribbon is not twisted and is correctly centred relative to the ZIF connector before insertion. Make sure that the ribbon cable contacts face in the same direction as the arrow on the following diagram. Push the latch on the connector down evenly until it is fully engaged.*

---

## 3. INSTALLATION

---

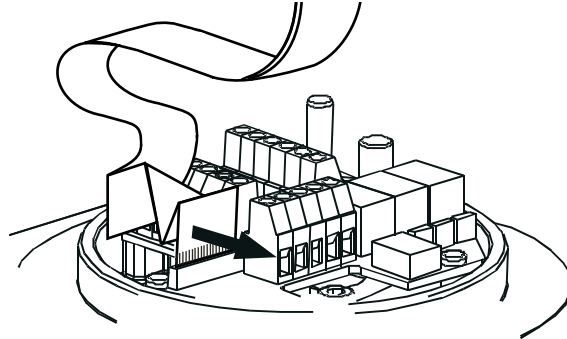

- (4) Refit the top to the Transmitter Unit base.

**Cautions:**

1. **Ensure that there is no moisture inside the unit before fitting the top.**
2. **Use only the captive bolts supplied, replacement with alternative bolts will invalidate certification.**

*The top should be located using the locating pins on the Apex base and then lowered onto the base. Ensure no wires are trapped and the O-ring in the top is correctly located. Check that there is no discernible gap between the top and the base.*

*Tighten the captive M8 bolts to 5Nm (3.68 foot-pounds).*

- (5) Check for correct operation of the system by carrying out the procedures described in the following section.

### 3.3.7 Operational Check

After installing the Communication Board and connecting the communication network wiring it is necessary to check that the Apex Transmitter Unit, Certified Sensor and Communication Board are working correctly together and also bind the equipment, which now acts together as a node, to the communication network.

- (1) Power-up the Transmitter Unit.
- (2) Check that the Transmitter Unit completes its start-up sequence successfully.

*The **Gas Reading** should be displayed. Refer to the Fault Diagnosis sub-section in **Chapter 4** if an error message is displayed.*

- (3) Press the **esc** button on the front panel.

---

## 3. INSTALLATION

---

The **Main Menu** is displayed.

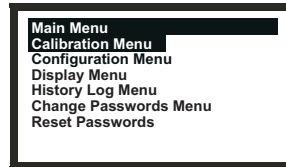

- (4) Select (highlight) the **Configuration Menu** option.  
Use the **up/down** keys.
- (5) Press the **ok** button.
- (6) Enter the current Level 2 password.

The **Configuration Menu** is displayed.

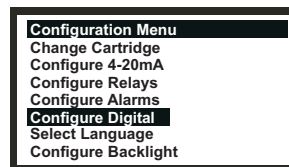

- (7) Select (highlight) the **Configure Digital** option.
- (8) Press the **ok** button.

Use the **up/down** keys.

The **Configure Digital** menu is shown displaying information similar to the following.

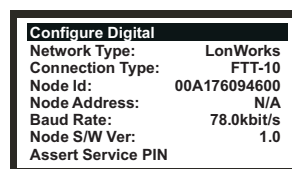

For a full explanation of the information see **Chapter 4**.

- (9) Select the **Assert Service PIN** option.
- (10) Press the **ok** button.

This binds the node to the network.

The display automatically returns to the **Configuration Menu**.

- (11) Press the **esc** button twice

This returns to the **Gas Reading** display via the **Main Menu**.

### 3.4 ACCESSORIES

All the accessories except for the Sunshade and filter are fitted to the Certified

---

## 3. INSTALLATION

---

Sensor in the same way.

To fit a filter see the filter replacement instructions given in **Chapter 5**.

For the dimensions of the accessories see **Chapter 2**.

### 3.4.1 Flow Housing, Weather Protection, Collecting Cone

To fit the Flow Housing, Weather Protection, Collecting Cone accessories carry out the following procedure.

- (1) Remove the Certified Sensor cap.

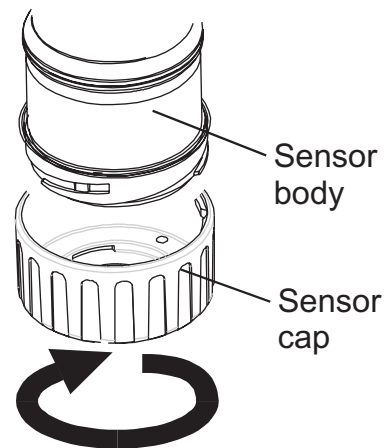

*Rotate the cap in an anticlockwise direction by 1/4 turn to release the bayonet fitting and pull off.*

- (2) Remove the rubber seal or filter from the sensor cap.

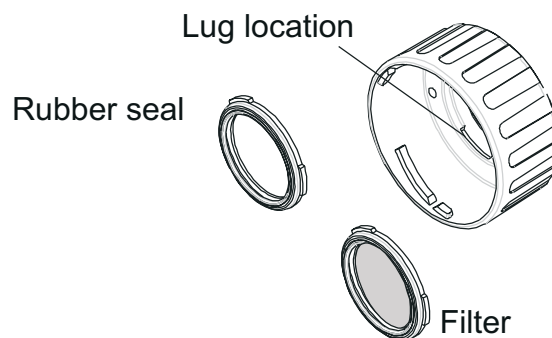

*The rubber seal or filter is held in place in the cap by its three lugs. Carefully prise the rubber seal or filter free from the lug location points in the cap or accessory.*

---

## 3. INSTALLATION

---

- (3) For the Collecting Cone only fit the cone onto the supplied housing.  
*The Collecting Cone is supplied as a kit of two parts that clip together.*
- (4) Fit the rubber seal/filter to the accessory.  
*Ensure that the rubber seal or filter is correctly installed in the accessory the correct way round with the three lugs closest to the front face of the accessory and correctly engaged in the locators.*
- (5) Fit the accessory onto the Certified Sensor body.  
*Reverse the cap removal procedure. The diagram shows the Flow Housing accessory fitted to the Certified Sensor.*

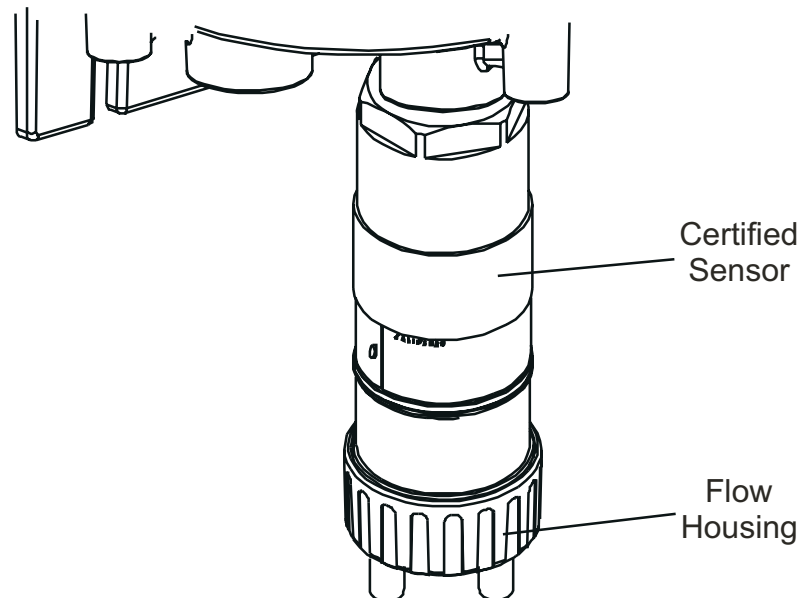

### 3.4.2 Sunshade

The sun shade can be used with other accessories in the range such as the Flow Housing, Weather Protection and Collecting Cone, but should be attached before any other accessories are fitted, or after their removal.

To fit the Sunshade accessory carry out the following procedure.

- (1) Remove the Certified Sensor cap or accessory.



---

## 4. OPERATION

---

The Apex gas measuring system is controlled from the Transmitter Unit via a menu system, displayed on an LCD screen, and a set of control buttons.

This chapter provides operational information about the following:

- **Display and control buttons**
- **Start-up**
- **Passwords**
- **Menus**
- **User Tasks**
- **Fault diagnosis**
- **System Calibration**
- **Binding the Communications Board to the Network**

If an optional digital communications board is fitted in the Transmitter Unit, e.g. LonWorks, then control can also be achieved from a remote location.

### 4.1 DISPLAY AND CONTROL BUTTONS

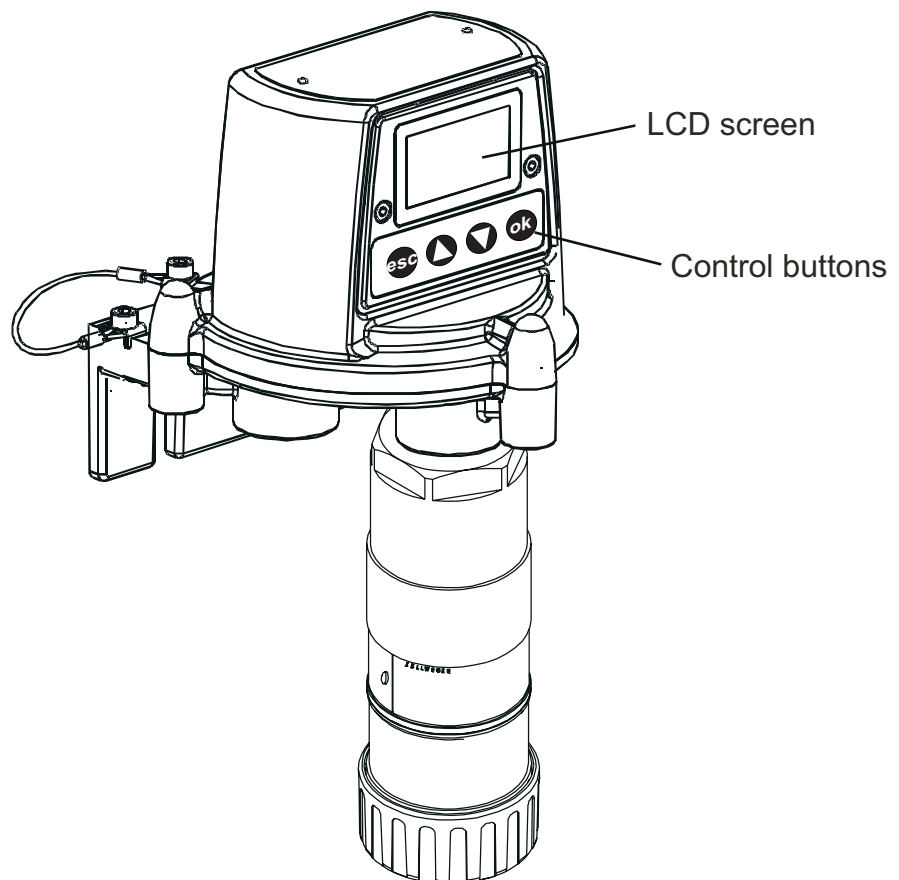

---

## 4. OPERATION

---





### 4.1.1 LCD screen

The screen provides a graphical user interface that, during normal operation, displays gas reading information. It also displays information about the system to the user, via a password protected hierarchical system of menus, together with system fault and information messages.

**Caution:** *Gas events occurring whilst in menus are not reported locally.*

### 4.1.2 Control buttons

The four buttons on the front panel below the LCD screen have the following functions:

-  (**esc**) is used to exit/cancel the current screen/option and return to the previous screen/option.
-  (**up**) is used to move upwards through the menu lists and to select (highlight) a required menu option. It is also used to increment displayed values.
-  (**down**) is used to move downwards through the menu lists and to select (highlight) a required menu option. It is also used to decrement displayed values.
-  (**ok**) is used to execute/acknowledge the chosen item.

The buttons are also used to enter the current password when required to access different menu levels (see **4.3** and **4.4**).

*Note: If a user response using the buttons is not made to a required menu action, e.g. change/accept a displayed setting value, then the system waits for approximately **10 minutes** before the process is aborted and the unit reverts to normal operation with the display showing the normal **Gas Reading** screen.*

*If a value had been displayed and not changed within the timeout period the system reverts to the status quo and uses the previously stored setting.*

---

## 4. OPERATION

---

### 4.2 START-UP

Switch on the power supply to the Apex Transmitter Unit.

With a correctly installed Certified Sensor the following information is shown sequentially on the LCD screen:

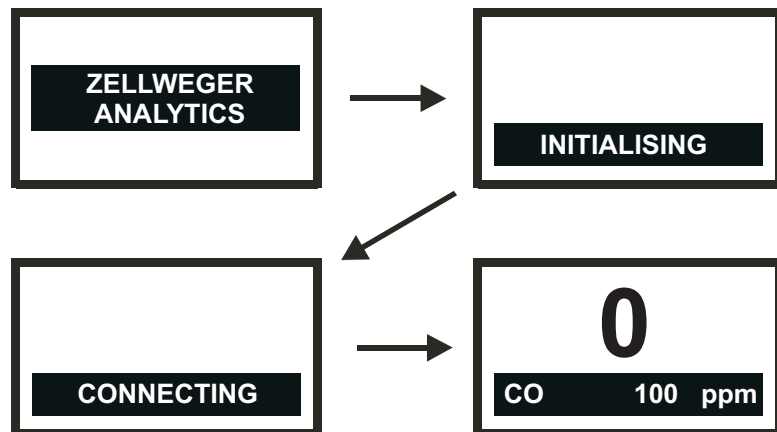

The Transmitter Unit initially waits for the Certified Sensor to stabilise, during which period the 4-20mA output is inhibited (2mA). Wait for **15 minutes** to ensure sensor stabilisation has occurred before continuing.

If the sensor does not stabilise during the initialisation period (**15 minutes**), one of the fault (**F**) or warning (**W**) alarm messages shown in Section 4.6 is displayed.

When the Certified Sensor stabilises, the LCD screen shows the current **Gas Reading** together with the gas identity, full scale, and the units of measurement.”

Note: If the current Gas Reading exceeds full scale the displayed reading will be replaced with ' >>>> '.”

This information is also transmitted on the 4-20mA output and optionally on the digital network if a communications board is fitted in the Transmitter Unit.

*Note: If the Transmitter Unit has a LonWorks Communications Board fitted then the unit will, at some stage, need to be bound to the LonWorks network. To do this carry out the LonWorks binding procedure described at the end of this chapter.*

### 4.3 PASSWORDS

**Caution: Always store passwords in a secure place. Do not let unauthorised users access to them.**

The different parts of the high-level menu structure are protected from different levels of user by assigning a set of three different passwords.

The three password levels correspond to the following types of system user:

---

## 4. OPERATION

---

- **Level 1**      **System operator**
- **Level 2**      **System technician**
- **Level 3**      **System administrator**

For example the **Level 1 Password** provides a system operator with access to day-to-day system operations, e.g. resetting alarms, checking the number of hours to the next Certified Sensor calibration, etc.

**Level 2 Password** could be assigned to a technician who needs to carry out more difficult operations such as calibrating the Certified Sensor.

**Level 3 Password** is for the system administrator to initially set and subsequently change passwords.





Once the three levels of password are specified then they are assigned to users by the system administrator depending on their access authority.

Each password consists of a sequence of control button presses.

When prompted during menu use, the user enters the current four-digit password required by pressing the four buttons in the correct sequence.

The entered password is represented on the LCD screen using asterisk characters (\*).

*Notes:*

1. *The last keystroke is not displayed on the screen. If the password is correct then the menu action previously selected is implemented immediately. If it is not correct the asterisks are cleared and the user must enter the correct password to proceed.*
2. *The default password supplied when the unit is first delivered is entered by pressing the     (ok, up, down and down) buttons in sequence. This provides initial access to all of the menus.*

The password level hierarchy allows the following:

- Functions available at **Level 1** can also be accessed by using the **Level 2** or **Level 3** passwords.
- Functions available at **Level 2** can also be accessed by using the **Level 3** password. They **cannot** be accessed by Level 1.
- Functions available at **Level 3** can only be accessed by using the **Level 3** password. They **cannot** be accessed by Level 1 or Level 2.

*Note: After changing, the three passwords can also be reset to the default value. Resetting all the passwords can only be carried out by the system administrator (see 4.3.2).*

### 4.3.1 Setting/changing passwords

This combined procedure describes how to initially set passwords and how to

---

## 4. OPERATION

---

subsequently change them.

- (1) Power-up the system.

*Wait for the **Gas Reading** display to stabilise.*

- (2) Press the **esc** button.

*The **Main Menu** is displayed.*

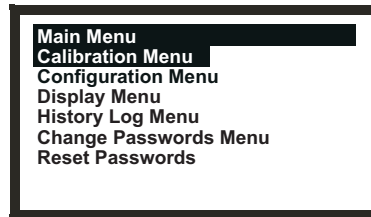





- (3) Navigate to the **Change Passwords Menu** option.

*Use the   (up/down) keys.*

- (4) Press **ok**.

- (5) Enter the current **Level 3** password.

*Use the buttons on the front panel. If setting passwords for the first time after unit delivery or password reset, enter the default password by pressing the     (ok, up, down and down) buttons in sequence. Passwords are shown using asterisks (\*) on the LCD.*

*The **Change Passwords Menu** is then displayed.*

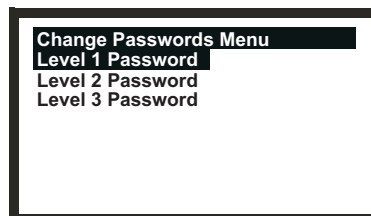

- (6) Navigate to the password level option to be changed.

*Use the   (up/down) keys.*

- (7) Press **ok**.

*The following screen is displayed:*

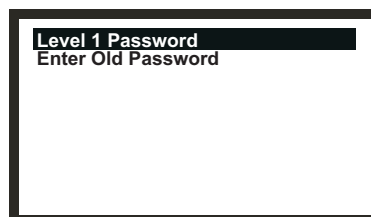

*This example shows the Level 1 Password screen. The screens for*

---

## 4. OPERATION

---

*Levels 2 and 3 are similar.*

- (8) Enter the current password for the chosen level.

*Use the buttons on the front panel. If setting the password for the first time after unit delivery or password reset, enter the default password by pressing the **ok** **▲** **▼** **▼** (**ok**, **up**, **down** and **down**) buttons in sequence. Passwords are shown using asterisks (\*) on the LCD.*

*The following screen is displayed:*

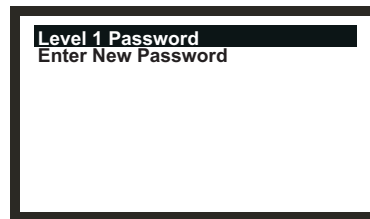

- (9) Enter the new password .

*The following screen is displayed:*

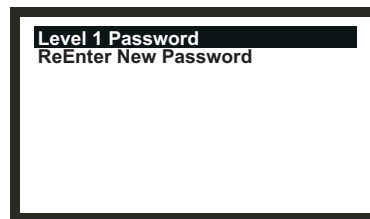

- (10) Enter the new password again .

*The following screen is displayed:*

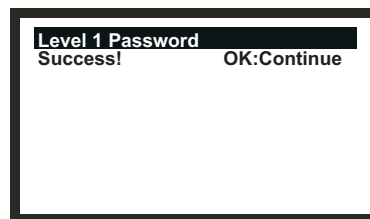

- (11) Press **ok**.

*The display returns to the **Change Passwords Menu**.*

*Follow the procedure to set/change another password or press **esc** to return to the **Main Menu**.*

*Note: If the wrong password is entered at the prompt during step 10 the following screen is displayed:*

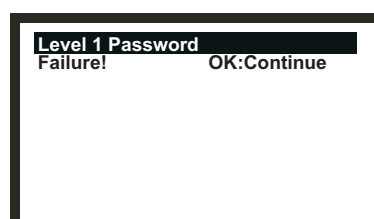

- (1) Press **ok**.

*The display returns to the **Change Passwords Menu**.*

- (2) Repeat the procedure re-entering the

---

## 4. OPERATION

---

*correct password.*

### 4.3.2 Password reset

The **Reset Passwords** option allows the system administrator to reset all the passwords back to the default password supplied when the unit is first delivered, i.e. **ok** **▲** **▼** **▼** (**ok, up, down and down**). This provides initial access to all of the menus.

To reset the access passwords to the default value carry out the following procedure:

- (1) Power-up the system.

*Wait for the **Gas Reading** display to stabilise.*

- (2) Press the **esc** button.

*The **Main Menu** is displayed.*

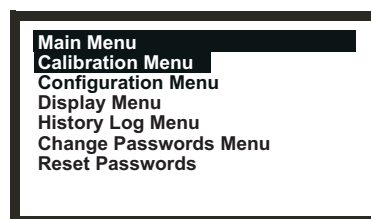

- (3) Navigate to the **Reset Passwords** option.

*Use the **up/down** keys.*

- (4) Press **ok**.

- (5) At the prompt enter the following sequence of **8** keystrokes:



**(up, down, ok, esc, esc, ok, down, up)**

*All the passwords are reset to their default value and the display returns to the **Main Menu**.*

### 4.4 MENUS

Menus are used to implement control of the Transmitter Unit.

The system **Main Menu** is accessed by pressing the **esc** button at the **Gas Reading** display.

## 4. OPERATION

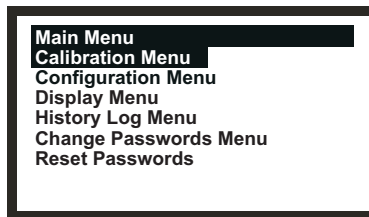

The **Main Menu** provides access to the primary tasks that are required when setting-up and controlling the Transmitter Unit and Certified Sensor. The following diagram summarises the menu hierarchy and options.

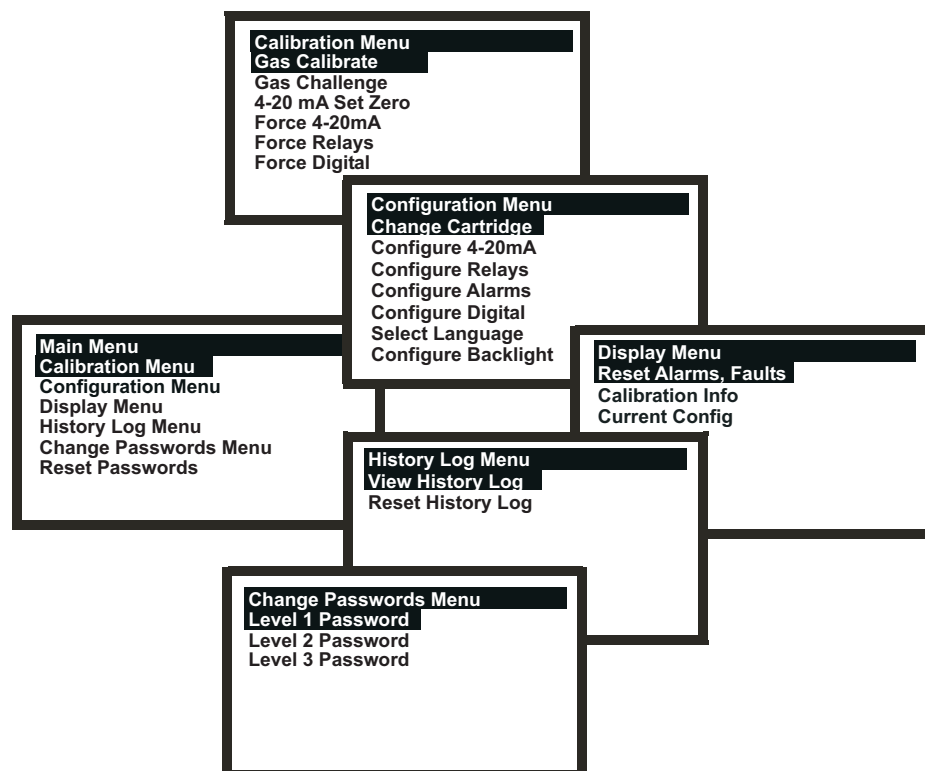

The subsequent subsections describe each of the main menu options in turn and show, using a flowchart format, how to access and implement their sub-options.



## 4. OPERATION

The following symbols are used on the flowchart diagrams:



Sub-menu option selected.

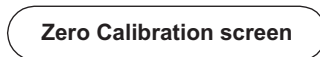

Sub-menu action.



User action.



System process.



Decision.



Comment/instruction.



Button press.

### 4.4.1 Calibration Menu

**Caution:** *The calibration procedure should only be performed by qualified personnel.*

**Caution:** *"If "Yes" is selected for the "Span Calibrate?" option, the span calibration must be completed successfully. Failure to do so will result in the unit signaling a "Calibration Needed" fault.*

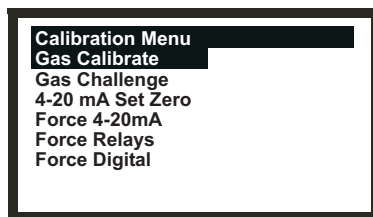

The **Calibration Menu** allows settings for the Transmitter Unit to be made, e.g. relay operation, and also settings for the Certified Sensor, e.g. gas calibrate.

This menu is protected by a **Level 2** password.

# 4. OPERATION

## Gas Calibrate

## Calibration Menu

This option calibrates the Certified Sensor zero gas point and the span setting point (see 4.7 for details of how to carry out this procedure).

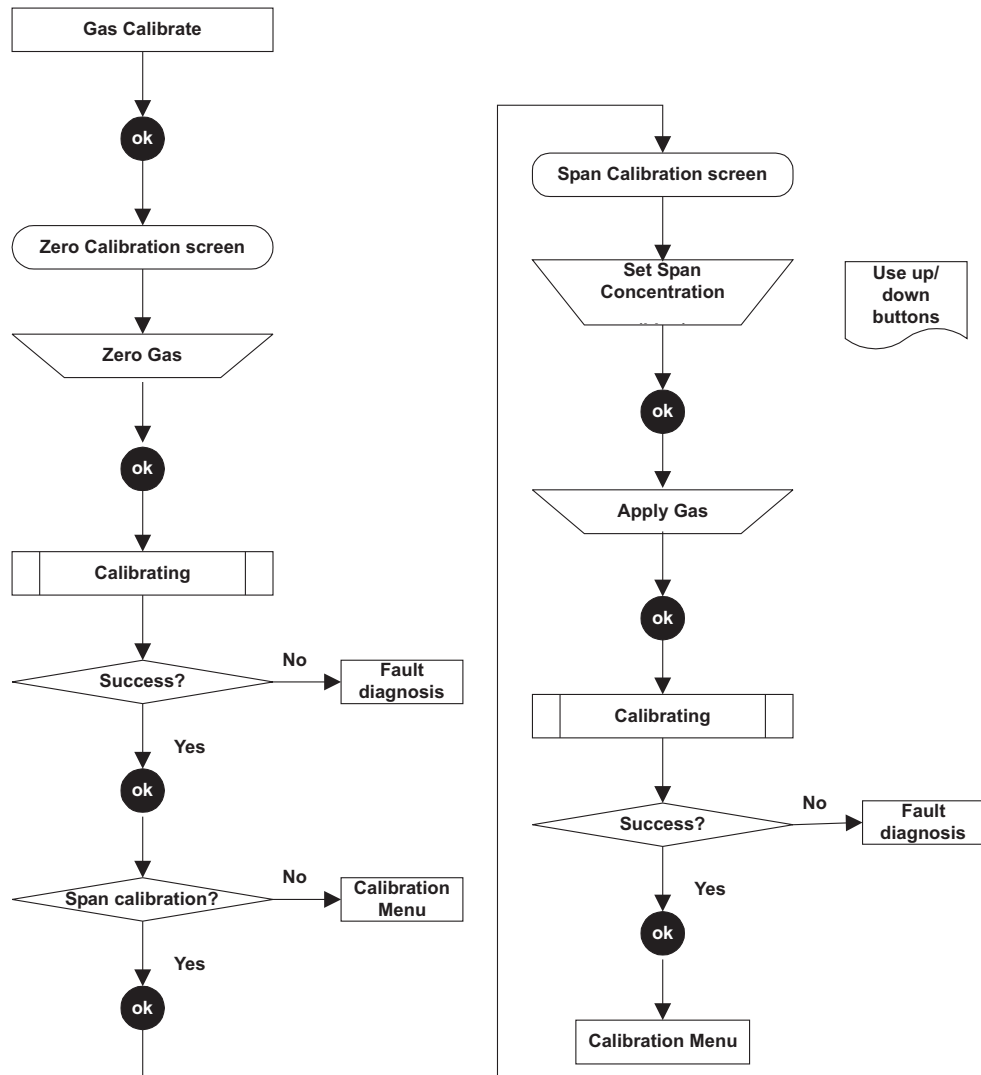

*Note: Depending on the type of gas cartridge fitted to the sensor, a choice of two calibration gases may be displayed during **Span Calibration**, e.g.  $C_7H_8$  has the options  $C_7H_8$  and  $CH_4$  as choices. If so choose the one that will be used for calibration and press **ok** to continue.*

## 4. OPERATION

### Gas Challenge

### Calibration Menu

#### **Cautions:**

- 1. Ensure that the area around the sensor is gas free before exiting the Gas Challenge mode.**
- 2. Upon leaving gas challenge mode, all outputs return to their active states (from inhibited). Ensure that values have returned to zero to avoid extraneous alarms.**

Provides the means to check correct operation of the unit in the presence of the gas being sensed without triggering alarms, etc.

Selecting this menu item puts the Transmitter Unit's 4-20mA output into Inhibit and prevents the relays from being energised. The Transmitter Unit does not signal Fault if one is induced.

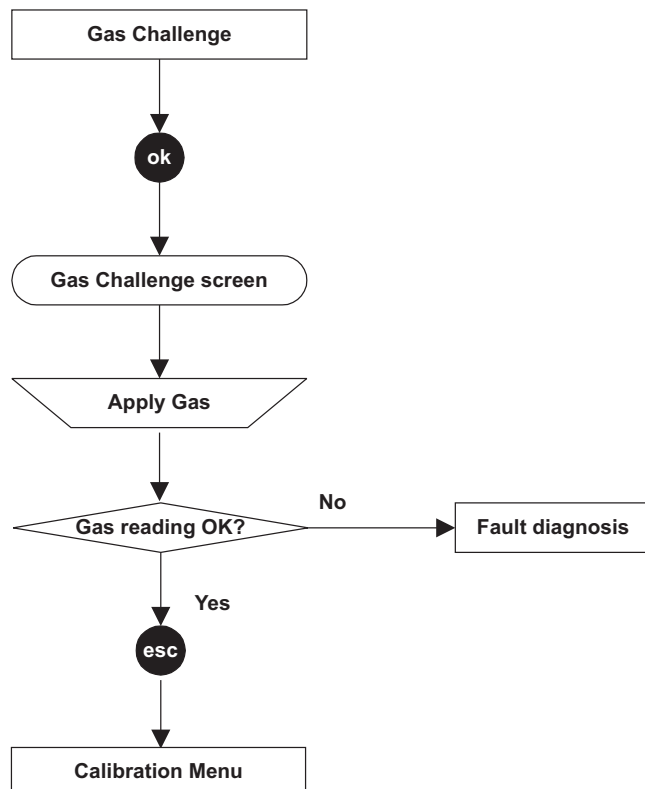

## 4. OPERATION

### 4-20mA Set Zero

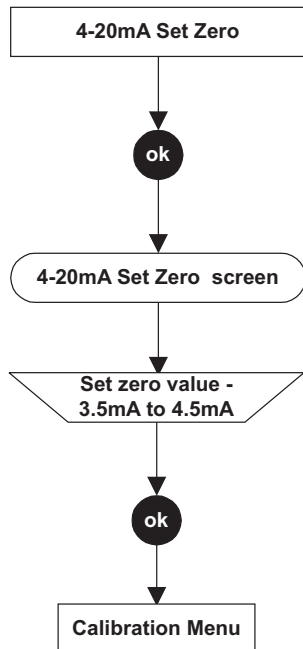

Use up/down buttons

### Calibration Menu

This option allows the zero point within the 4-20mA signal range to be adjusted between 3.5 and 4.5mA. The default setting is 4.0mA. The offset applies to all 4-20mA output states including Inhibit, Warning, Overrange and Alarms.

### Force 4-20mA

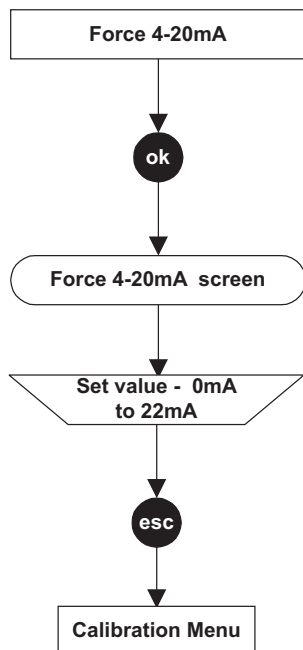

Use up/down buttons

### Calibration Menu

**Caution:** *Ensure that when forcing a signal on the 4-20mA output that the effects on the network and controller are understood.*

This option allows the 4-20mA output to be forced to a level selected between 0 and 22mA. The default is 1mA. The forced setting times out after approximately 5 minutes and the output returns to normal active operation.

# 4. OPERATION

## Force Relays

## Calibration Menu

**Caution:** *Ensure that when forcing a relay response that the effects on the network and controller are understood, e.g. alarm activation, etc.*

Provides the means to test the operation of the Transmitter Unit's relays by forcing them in turn to be energised/de-energised.

Relays return to normal set states when in **Main Menu** or after a timeout period of approximately **5 minutes**.

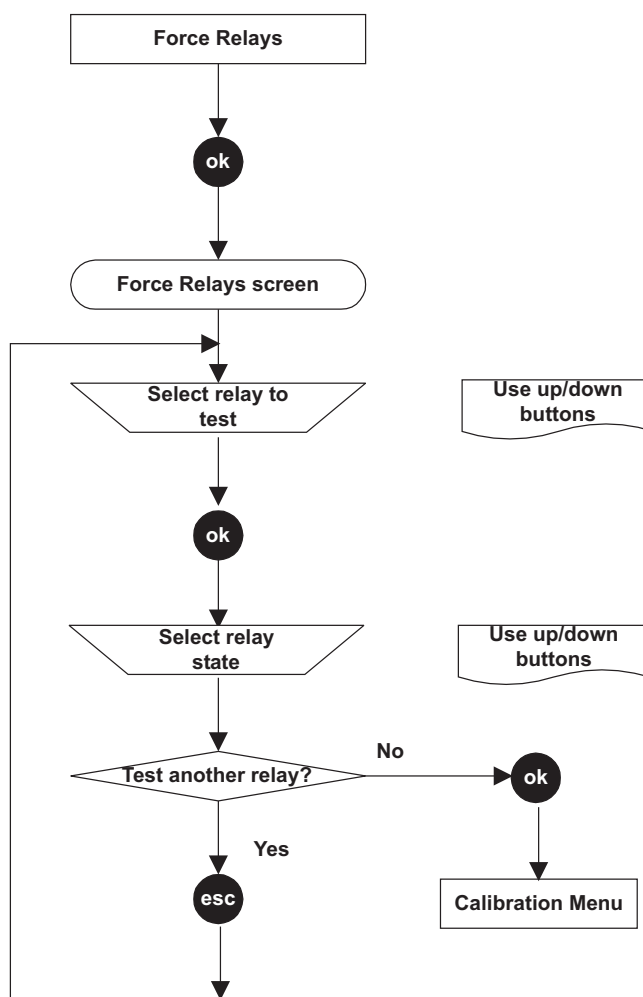

## 4. OPERATION

### Force Digital

### Calibration Menu

**Caution:** *Ensure that when forcing a signal on the digital output that the effects on the network and controller are understood, e.g. alarm activation, etc.*

This option allows the digital output (if a digital communications board is fitted to the Transmitter Unit, e.g. LonWorks) to be forced to output an alarm signal, from Alarm 1 or Alarm 2 or no alarm.

Times out after approximately 5 minutes. The 4-20mA output and relays are unaffected.

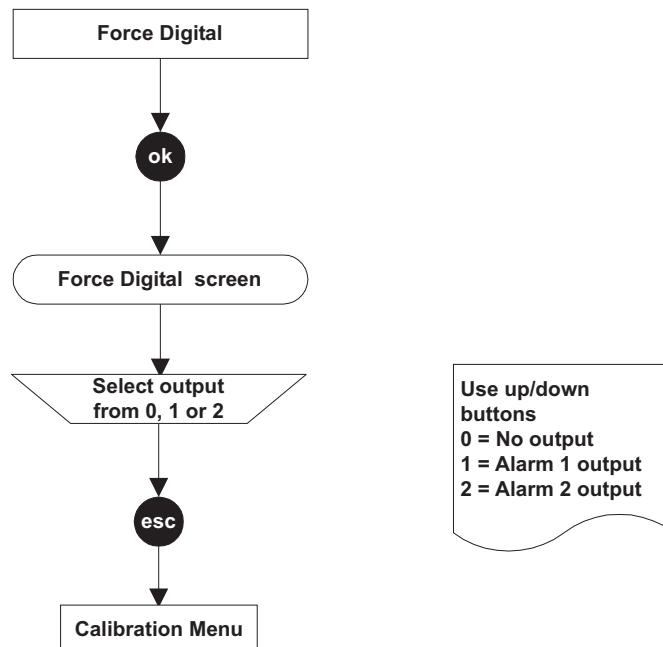

---

## 4. OPERATION

---

### 4.4.2 Configuration Menu

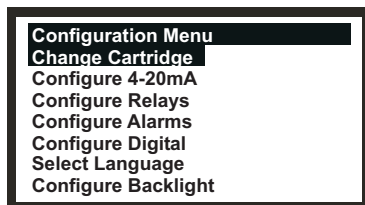

*Note: The **Configure Backlight** option is not available on CSA Certified Transmitter Units.*

The Configuration Menu changes settings for the Transmitter Unit, e.g. alarm operation, and also configures Certified Sensor operations, e.g. when changing the Certified Sensor gas cartridge.

This menu is protected by a **Level 2** password.

---

#### **Change Cartridge**

---

#### **Configuration Menu**



#### **WARNINGS**

Change cartridges using the procedure described below. Failure to correctly follow this procedure could result in the wrong cartridge being installed, and possibly non-detection of events. Alternatively, extraneous alarms could be triggered by chemicals detected but not of concern at a particular location.

Sensor Cartridges may contain corrosive solutions. Dispose of according to local and national regulations.

This menu item allows the Certified Sensor gas cartridge to be changed under controlled conditions without generating faults or alarms. The process detects the presence or absence of the cartridge.

If a new cartridge type is inserted, the default alarm thresholds are loaded into the Transmitter Unit.

*Note: If the new cartridge has different parameters to the previous cartridge, these are displayed for the operator to verify.*

If a new cartridge of the same type as previously used is inserted, the configured alarm thresholds of the Transmitter Unit are loaded into the new cartridge's actual parameters.

**Caution:** *This only works if the **Lowest Allowable Alarm Level (LAL)** of the new cartridge is lower than the transmitter's configured alarm threshold. If it is not, a Fatal Fault error occurs.*

This menu uses procedures from **Chapter 5** where details about how to physically change the cartridge are provided.

## 4. OPERATION

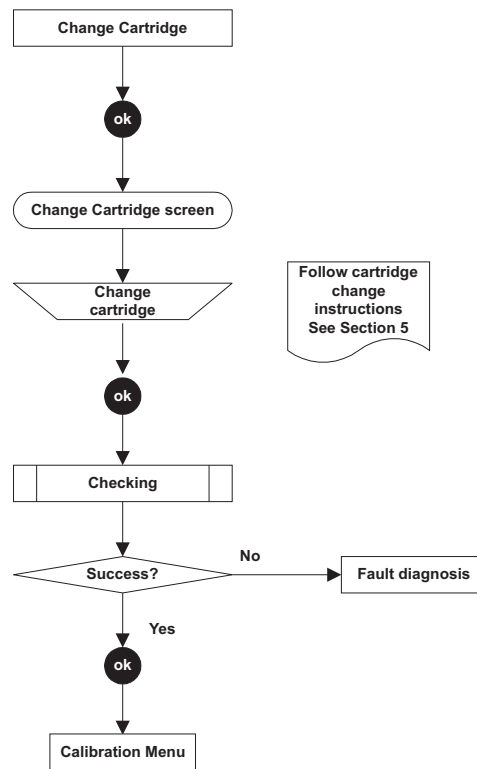



# 4. OPERATION

## Configure 4-20mA

## Configuration Menu

Provides the means to configure the values for the 4-20mA signal output settings. Three settings are available:

- Inhibit**                      Value 1mA to 4mA, default is 1mA.
- Warning**                     Value 1mA to 6mA, default is 3mA.
- Overrange**                  Value 20mA to 21.5mA, default is 21mA.

Caution: When compliance with the ATEX EN50054 performance standard is required the warning and inhibit current shall not be configured to a value between than 3.1mA and 4.9mA

Once configured to a new value, the new value is output when the corresponding states occur.

When the Warning current is configured to be greater than 4mA the output pulses to the configured Warning current for approximately 1 second every 10 seconds.

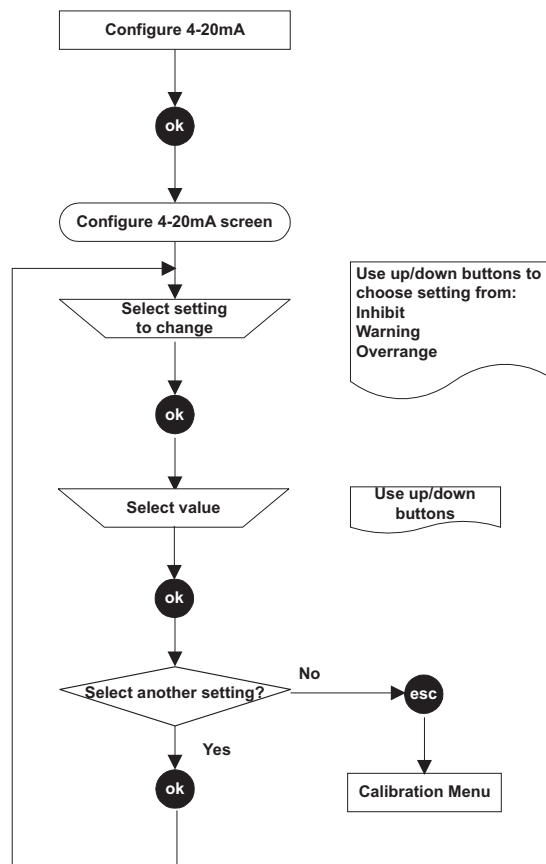

## 4. OPERATION

### Configure Relays

### Configuration Menu

This option allows the three Transmitter Unit relays to be configured for the current installation.

Latched relays are cleared by the **Display Menu => Reset Alarms, Faults** option or by switching the power off and on.

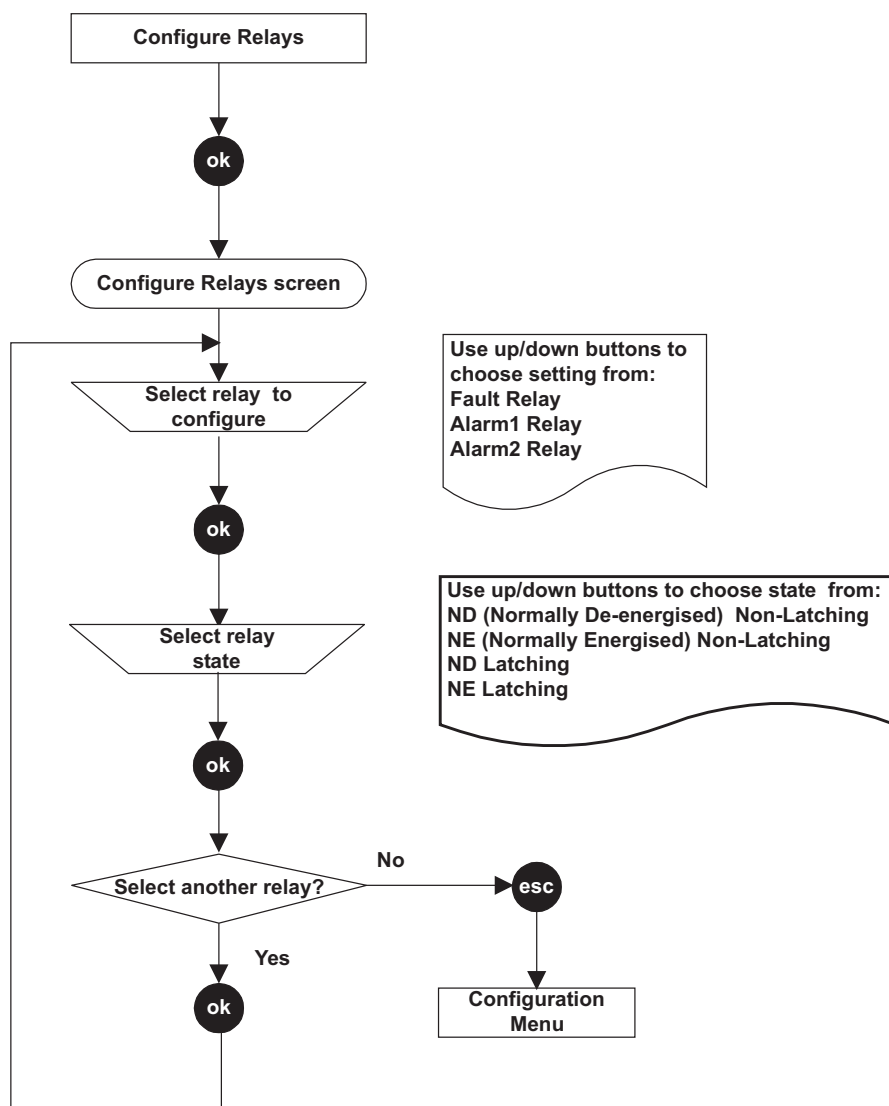

*Note: Alarm recovery is below alarm setpoint (25%).*

As well as the ability to set the default state of the relay operation (energised or de-energised and latching or non-latching) by this method it is possible to set whether the relay contacts are normally open or normally closed by means of the links on the Transmitter Unit's Interconnect PCB (also see **Chapter 3**).

## 4. OPERATION

### Fault relay configuration example

**Requirement:** Normally De-energised, Non-Latching with the contact Normally Closed.

**Implementation:** Use the **Configure Relays** menu option to set the **Fault** relay operation requirement. Place the jumper on the **J1** link to set the contact operation as follows:

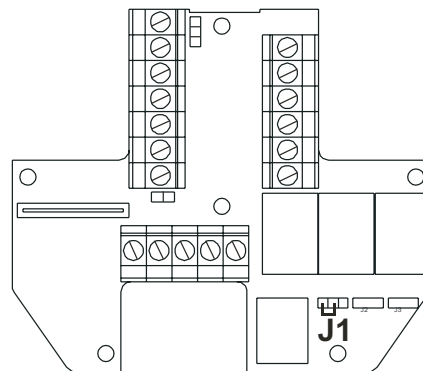

This circuit diagram shows this.

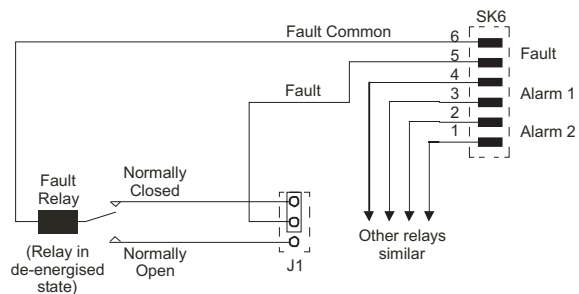

# 4. OPERATION

## Configure Alarms

## Configuration Menu

**Caution:** Alarm 2 value can be set below Alarm 1 value.



When installed to measure flammable gas it is essential that either the Transmitter unit or control network is configured to latch the overrange condition. If the Transmitter unit local relays are used this should be achieved by enabling the overrange latching function of the Transmitter unit. Depletion of oxygen as a consequence of displacement by flammable gas can result in the gas reading returning to zero.

Provides the means to configure the point at which the alarms activate and whether overrange latching is required. The range of settings depends on the type of gas cartridge fitted to the Certified Sensor.

When the Transmitter Unit's alarm thresholds are changed, the actual cartridge parameters are updated to reflect the Transmitter Unit's configured values.

The default state for Overrange latching is not latched.

When activated, overrange latching causes the Transmitter Unit to latch the A1 and A2 Alarm relays and the 4-20mA output if an overrange gas condition is detected. Overrange latching only effects alarm relay latching after an overrange condition, not at the A1 and A2 alarm thresholds. Overrange latching only operates in the normal Transmitter Unit active condition, not in Gas Challenge or Gas calibrate conditions.

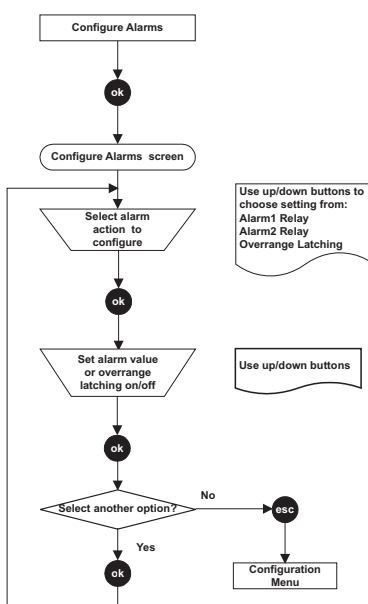

# 4. OPERATION

## Configure Digital

## Configuration Menu

This menu item displays a screen that reports information about digital communications if a digital communications board is fitted to the Transmitter Unit, e.g. LonWorks. An example of a typical screen is as follows:

<b>Configure Digital</b>	
<b>Network Type:</b>	LonWorks
<b>Connection Type:</b>	FTT-10
<b>Node Id:</b>	00A176094800
<b>Node Address:</b>	N/A
<b>Baud Rate:</b>	78.0kbit/s
<b>Node S/W Ver:</b>	1.0
<b>Assert Service Pin</b>	

- Network Type* Displays the type of digital network installed.
- Connection Type* Shows the type of transceiver used for digital output.
- Node Id* Displays the identifier for the Transmitter Unit.
- Node Address* Shows the address of the unit on the digital network, if applicable.
- Baud Rate* Displays the current network communications rate.
- Node S/W Ver* Shows the version of the board software.

The list also provides a choice, **Assert Service Pin**, to bind the Transmitter Unit to the host digital network (see 4.8).

**Caution:** *If a Transmitter Unit is replaced, including the LonWorks PCB, the replacement unit must be rebound to the LonWorks network. If the LonWorks PCB is removed from a faulty Transmitter Unit and fitted into a new Transmitter Unit, then the previous binding remains operational.*

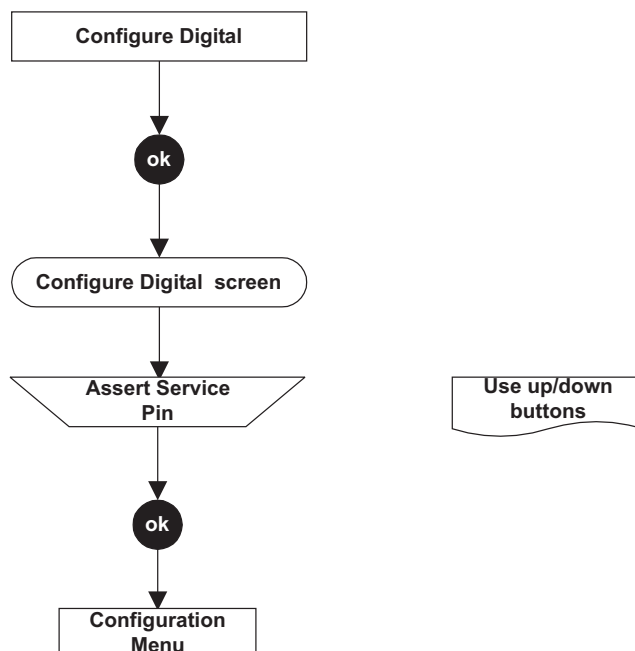

## 4. OPERATION

### Select Language

### Configuration Menu

Provides the means to change the language in which text on the LCD screen is displayed.

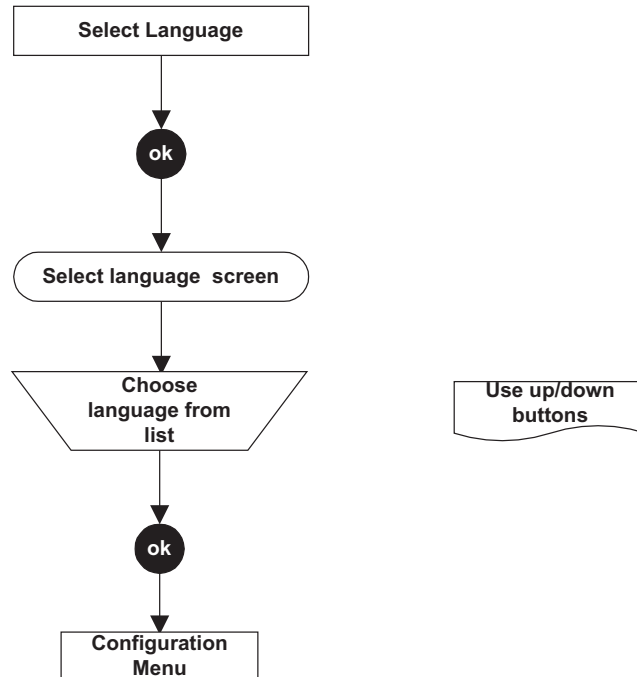

### Configure Backlight

### Configuration Menu

This option allows the LCD screen backlight to be switched on or off.

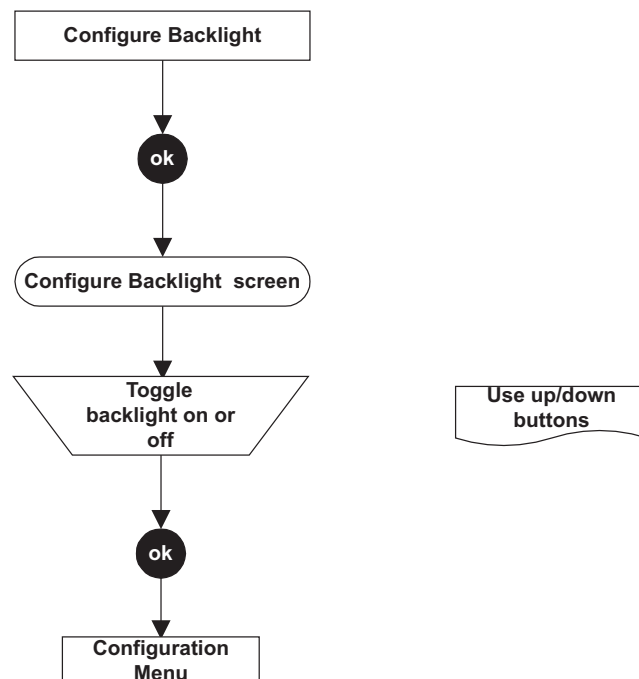

#### Notes:

1. The **Configure Backlight** control is not available on CSA Certified Transmitter Units.
2. The backlit screen is best viewed in a darkened location.

# 4. OPERATION

## 4.4.3 Display Menu

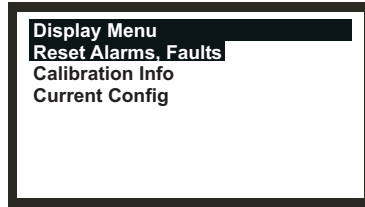

The **Display Menu** reports back the current settings for the Transmitter Unit and Certified Sensor, e.g. calibration and configuration setting information.

This menu is protected by a **Level 1** password.

### Reset Alarms, Faults

### Display Menu



### WARNING

Alarms should **not** be reset until it is confirmed that gas is not present.

This option displays a screen that reports the state of each of the Transmitter Unit alarms. These are *Fault Relay*, *Alarm1 Relay*, *Alarm2 Relay* and *Overrange*. Each of these can be *Active* or *Inactive*.

It also allows latched alarms and overrange to be reset provided that the conditions responsible for causing them are no longer present.

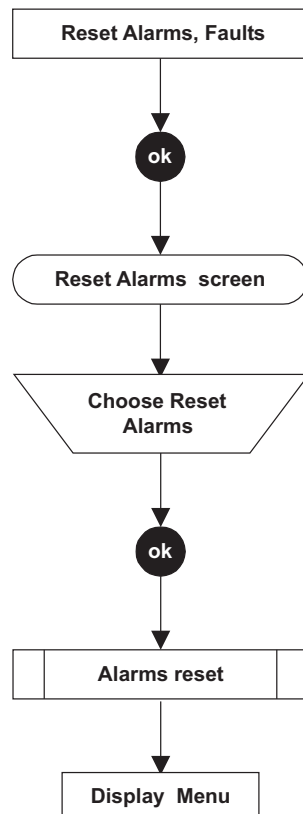

Use up/down buttons

*Note: Alarms are **not** reset until the **esc** button is pressed to leave the **Display Menu** and return to the **Main Menu**.*

## 4. OPERATION

### Calibration Info

### Display Menu

This option displays a screen that reports information about the calibration of the Transmitter Unit and Certified Sensor. An example of a typical screen is as follows:

Calibration Info	
Last Calib:	163
Next Calib:	4205
Gas:	PH3
FSD:	1.200 ppm
Calib Interval:	4368
Predicted Life:	8571

<i>Last Calib</i>	Displays the time in hours since the last calibration was carried out.
<i>Next Calib</i>	Displays the time in hours to the next calibration based on the <i>calibration interval (Calib Interval)</i> .
<i>Gas</i>	Displays the type of gas cartridge fitted to the Certified Sensor.
<i>FSD</i>	Displays the maximum range of measurement.
<i>Calib Interval</i>	Displays the calibration interval in hours.
<i>Predicted Life</i>	Displays the typical life of the cartridge in hours.

### Current Config

### Display Menu

This option displays **2 screens** sequentially that report the current Transmitter Unit and Certified Sensor configuration settings, e.g. alarm settings, relay configurations, etc.

#### Initial Screen

An example of a typical initial screen is as follows:

Current Config	
Gas:	PH3
FSD:	1.200 ppm
Alarm1:	0.150 ppm
Alarm2:	0.300 ppm
Inhibit:	1.2 mA
Warning:	3.0 mA
Overrange	21.0 mA

<i>Gas</i>	Reports the type of gas cartridge fitted to the Certified Sensor.
<i>FSD</i>	Displays the maximum range of gas measurement.
<i>Alarm1</i>	Reports the alarm value set for Alarm1.
<i>Alarm2</i>	Displays the alarm value set for Alarm2.
<i>Inhibit</i>	Reports the value at which the 4-20mA Inhibit alarm is set to activate.



## 4. OPERATION

<i>Warning</i>	Displays the value at which the 4-20mA Warning alarm is set to activate.
<i>Overrange</i>	Reports the value at which the 4-20mA Overrange alarm is set to activate.

### Second Screen

The second screen is displayed after navigating past the last entry on the initial screen by using the **down** button. A typical example is as follows:

Current Config	
Fault Relay:	NE/L
Alarm1 Relay:	NE/NL
Alarm2 Relay:	NE/NL
Tx Version:	1.02
Sensor Version:	1.2

<i>Fault Relay</i>	Reports the contact configuration (see Note) for the Fault Relay.
<i>Alarm1 Relay</i>	Displays the contact configuration (see Note) for the Alarm1 Relay.
<i>Alarm2 Relay</i>	Reports the contact configuration (see Note) for the Alarm2 Relay.
<i>Tx Version</i>	Displays the current version of the transmitter software.
<i>Sensor Version</i>	Reports the current version of the Certified Sensor software.

#### Note:

*The abbreviations used on the screen for the contact settings mean the following:*

<b>ND</b>	<i>Normally De-energised</i>
<b>NE</b>	<i>Normally Energised</i>
<b>L</b>	<i>Latching</i>
<b>NL</b>	<i>Non-Latching</i>

---

## 4. OPERATION

---

### 4.4.4 History Log Menu

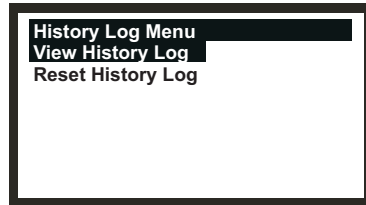

The **History Log Menu** enables the recorded log for the unit to be viewed by the operator and also reset, or cleared. The log contains information about events that happen during the life of the Transmitter Unit, e.g. time of last Certified Sensor calibration, time of last alarm, etc.

This menu is protected by a **Level 2** password.

---

#### **View History Log**

---

#### **History Log Menu**

This sub-menu item displays screens that consist of one or more pages of information, each displaying a message, recording the history of the unit since the log was last reset. The most recent event is viewed first.

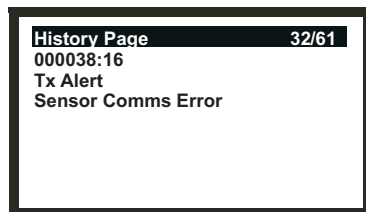

To navigate through the unit's history use the **up/down** buttons to view different pages.

*Note: Keep the button pressed continuously to quickly scroll through the pages of a large log record.*

The top line of the message indicates the current page number and then the total number of pages in the log. An example is **22/45**, i.e. **22nd** page of **45** pages.

The next line contains the history clock time in hours and minutes since the event occurred. Each time you subsequently view this time therefore it will be different.

To calculate the date/time of a recorded event take the displayed time on screen away from the current date/time.

The next lines contain the text of the log recording the event.

After viewing the page(s) use the **esc** button to return to the **History Log Menu**.

*Notes:*

1. *There is a maximum of 64 history entries. The first and subsequent recorded entries are overwritten as the log exceeds this figure.*
2. *The log time is **not** incremented when the unit is powered down.*

## 4. OPERATION

### Reset History Log

### History Log Menu

**Caution:** *Resetting the log removes all recorded data and resets the history clock to zero.*

This option is used to clear the current message content of the history log.

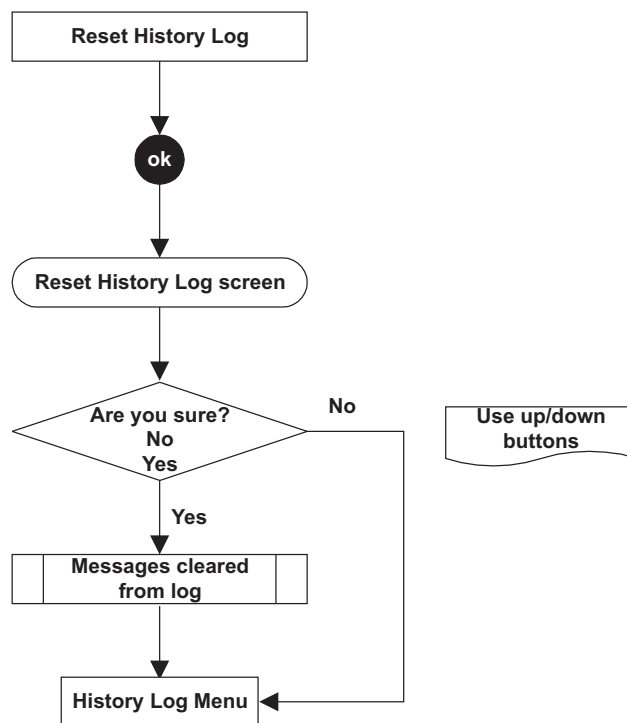

### 4.4.5 Change Passwords Menu

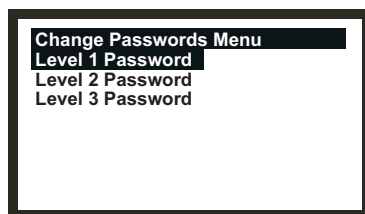

The **Change Passwords Menu** allows the system administrator to change the passwords for each of the three levels of access.

This menu is protected by a **Level 3** password.

### Level 1 Password

### Change Passwords Menu

This sub-menu item allows the **Level 1 Password** to be changed.

## 4. OPERATION

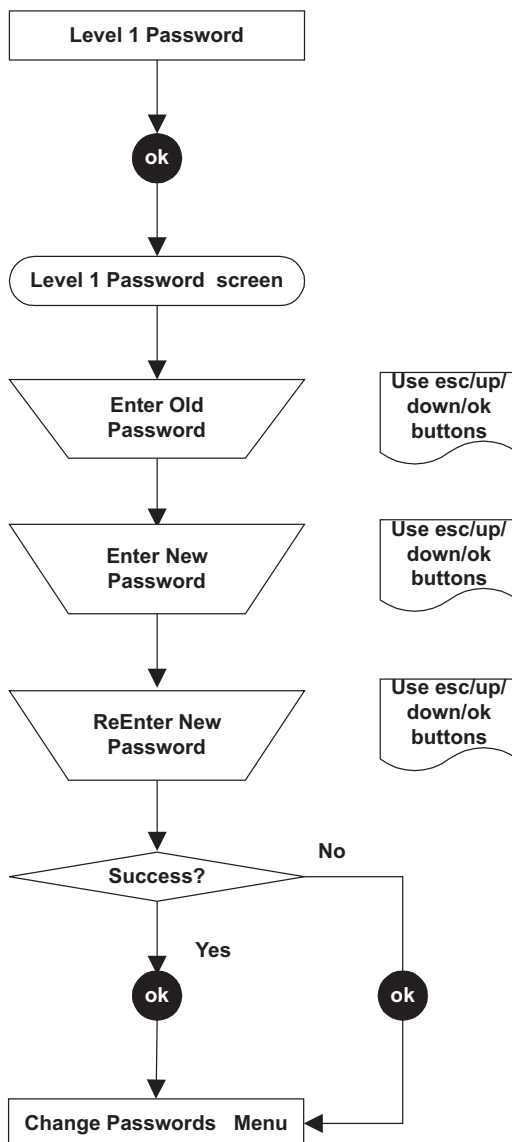

### Level 2 & Level 3 Password

### Change Passwords Menu

Both these sub-options allow the password to be changed in the same way as for the **Level 1 Password**.

#### 4.4.6 Reset Passwords

The **Reset Passwords** option allows the system administrator to reset all the passwords back to the default password supplied when the unit is first delivered, i.e. **ok** **▲** **▼** **▼** (ok, up, down and down). This provides initial access to all of the menus. Access to the **Reset Passwords** option requires a special password that consists of the following sequence of 8 (not 4) control button presses:

**▲** **▼** **ok** **esc** **esc** **ok** **▼** **▲**  
 (up, down, ok, esc, esc, ok, down, up)

## 4. OPERATION

### 4.5 USER TASKS

The following table provides a quick reference list of typical tasks and how to carry them out via the menu system.

Tasks related to:	Sub-Menu	Sub-Menu Option	User Level
<b>4-20mA loop</b>			
Set Inhibit, Warning and Overrange levels	Configuration	Configure 4-20mA	2
Zero setting	Calibration	4-20mA Set Zero	2
Test operation	Calibration	Force 4-20mA	2
<b>Alarms</b>			
Set overrange latching on or off	Configuration	Configure Alarms	2
Set gas alarm levels	Configuration	Configure Alarms	2
Reset alarms	Display	Reset Alarms	1
<b>Checking the unit's settings</b>			
Calibration settings	Display	Calibration Information	1
Configuration settings	Display	Current Configuration	1
<b>Checking the unit's operational history</b>			
View the unit's log	History Log	View History Log	2
Clearing the history log	History Log	Reset History Log	2
<b>Digital communications</b>			
View settings	Configuration	Configure Digital	2
Register the communications board	Configuration	Configure Digital	2
Test operation	Calibration	Force Digital	2
<b>Display Screen</b>			
Turn backlight on/off *	Configuration	Configure Backlight	2
Change the on-screen display language	Configuration	Select Language	2
<b>Gas</b>			
Test unit with gas	Calibration	Gas Challenge	2
Change a gas sensor cartridge	Configuration	Change Cartridge	2
Calibrate gas	Calibration	Gas Calibrate	2
<b>Passwords</b>			
Change a password	Change Passwords	Level 1 Password	3
	Change Passwords	Level 2 Password	3
	Change Passwords	Level 3 Password	3
Reset all passwords to default	Reset passwords		3
<b>Relays</b>			
Set-up relay contacts	Configuration	Configure Relays	2
Test relays	Calibration	Force Relays	2

\* The **Configure Backlight** control is not available on CSA Certified Transmitter Units.

## 4. OPERATION

### 4.6 FAULT DIAGNOSIS

Apex system faults can be those displayed on the Transmitter Unit screen or be of a general type. This section describes:

- **Error messages displayed on the Transmitter Unit LCD screen.**

*These are either fault or warning types. They can normally be corrected at the Transmitter Unit or Certified Sensor.*

- **Errors that are not diagnosed by the system itself but need some action.**

*For example the Certified Sensor reads low when gas is applied. To rectify this fault the control system span needs to be adjusted.*

- **Signal ranges and fault conditions on the 4-20mA output.**
- **How to clear latched alarms**

#### 4.6.1 Displayed Error Messages

The error messages on the LCD screen are similar to the following:

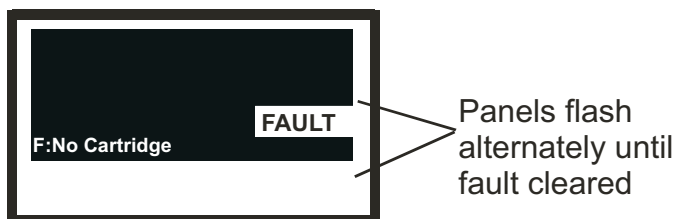

The following table lists all the displayed Fault (F) and Warning (W) messages.

Message	Cause/Remedy
<b>F: Sensor Failed</b>	A Certified Sensor fault has developed. Check the connections between transmitter and Certified Sensor. If fault remains replace the complete Certified Sensor assembly.
<b>F: No Cartridge</b>	The Certified Sensor reports there is no cartridge fitted. Check that the cartridge is fitted correctly. If no cartridge present, fit required cartridge.
<b>F: Wrong Cartridge</b>	The wrong type of cartridge has been fitted in the Certified Sensor. Replace the cartridge with correct type for the target gas.
<b>F: Cartridge Failed</b>	The cartridge has failed. Replace the cartridge.

## 4. OPERATION

<b>W: Temperature Error</b> <b>F: Temperature Error</b>	The cartridge is being operated at temperatures outside its specified temperature range. Identify the cause of temperature problem. Fit suitable accessories or relocate the Certified Sensor as appropriate. If fault persists replace the Certified Sensor.
<b>W: End of Cell Life</b> <b>F: End of Cell Life</b>	The cartridge is reaching, or has reached, the end of its useful service life. <b>Warning</b> - replace the cartridge within the next 3 months. <b>Fault</b> - replace the cartridge <b>immediately</b> .
<b>W: Calibration Needed</b> <b>F: Calibration Needed</b>	The cartridge requires calibration. Perform zero and span calibration procedures.
<b>FATAL FAULT</b>	A fatal error has occurred. Note the displayed fault code and conditions, and contact the manufacturer for advice.
<b>NO SENSOR</b>	The transmitter can not detect the presence of the sensor.
<b>Sensor Comms Fail</b>	Sensor incorrectly connected or faulty. Check connections between Certified Sensor and transmitter unit. If connections correct but message remains, replace Certified Sensor.

### 4.6.2 General Faults

The following table lists symptoms and causes for general fault diagnosis.

<b>Gas Reading Symptom</b>	<b>Cause/Remedy</b>
<b>Non-zero all the time</b>	Gas could be present, ensure that there is no target gas in the atmosphere. Background or other volatile organic gases that may be present, e.g. solvents, can interfere with the operation of the Certified Sensor.
<b>Non-zero when no gas is present</b>	Adjust the system zero. <b>(Calibration Menu =&gt; Gas Calibrate).</b>
<b>Low when gas is applied</b>	Adjust the system span concentration setting. <b>(Calibration Menu =&gt; Gas Calibrate).</b>
<b>High when gas is applied</b>	Adjust the system span concentration setting. <b>(Calibration Menu =&gt; Gas Calibrate).</b>
<b>Zero when gas is applied</b>	Check that the Certified Sensor gas entry is not obstructed. Check that the sinter and any filter, if fitted, is not blocked. Replace the cartridge. <b>(Configuration Menu =&gt; Change Cartridge).</b>

## 4. OPERATION

### 4.6.3 4-20mA output signal ranges and fault conditions

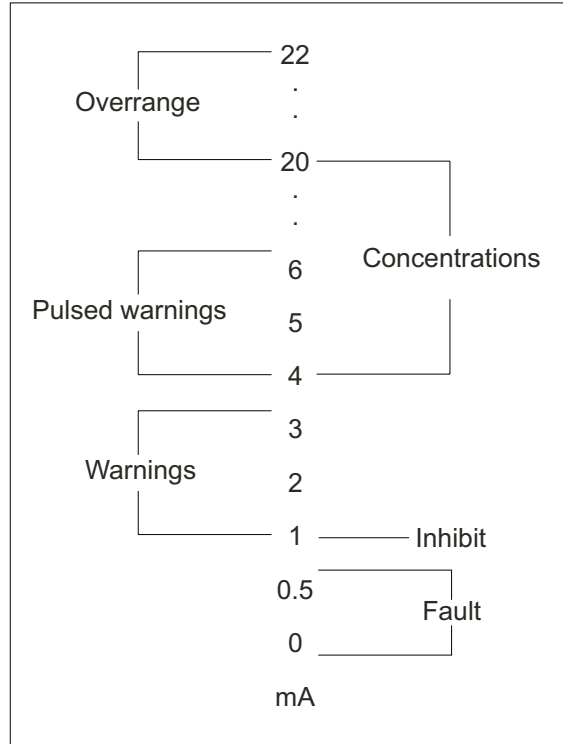

General Fault Type	Output Signal Level	Fault Conditions
<b>Faults</b>	<b>0 - 0.5mA</b> (default is 0.5mA)	Sensor Failed No Cartridge Wrong Cartridge Cartridge Failed Temperature Error End of Cell Life Calibration Needed No Sensor, Sensor Comms Fail Fatal Fault
<b>Warnings</b>	<b>1.0 - 3.5mA - constant</b> <b>4.0 - 6.0mA - pulsed 1/sec</b> (default is 3mA)	Temperature Error End of Cell Life Calibration Needed
<b>Over range Warnings</b>	<b>20 - 21.5mA</b> (default is 21mA)	Gas Reading exceeded full scale
<b>Inhibit</b>	-	Locks relays and outputs



---

## 4. OPERATION

---

### 4.6.4 Clearing latched alarms



#### WARNING

Alarms should **not** be reset until it is confirmed that gas is not present.

The fault and alarm relays may be set to be latched (see **Configuration Menu**). So when an alarm message is displayed on the LCD screen it may continue to be displayed even when the fault causing the problem is corrected.

*Note: Alarms may not be set to be latched, but because alarm recovery is set 25% below alarm setpoint it could appear that they are for a short while.*

To reset a latched alarm carry out the following procedure:

- (1) Press **esc** at the **Gas Reading** display.

*The Main Menu is displayed.*

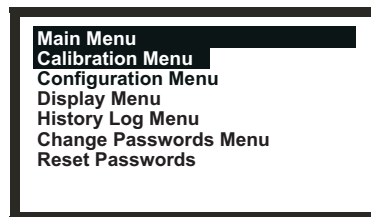

- (2) Select (highlight) **Display Menu** from the list.
- (3) Press **ok**.
- (4) When prompted enter the current Level 1 password.

*Obtain the password from the system administrator.*

*The Display Menu is shown.*

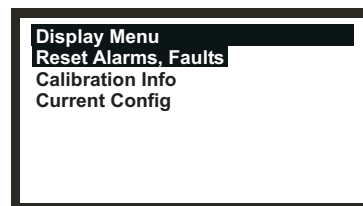

- (5) Select the **Reset Alarms, Faults** option.
- (6) Press **ok**.

*The Reset Alarms, Faults menu is displayed.*

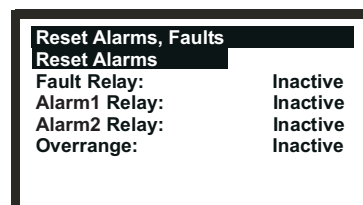

---

## 4. OPERATION

---

*The menu displays the state of the fault and alarm relays and the overrange.*

- (7) Select **Reset Alarms** from the list.
- (8) Press **ok**.

*The display returns to the **Display Menu**.*

*Note: Alarms are not reset until the **esc** button is pressed to leave the **Display Menu** and return to the **Main Menu**.*

### 4.7 SYSTEM CALIBRATION

**Caution:** *The calibration procedure should only be performed by qualified personnel.*

This section describes how to calibrate the gas cartridge fitted to an Apex Certified Sensor. The Transmitter Unit and other system components do not require calibration. This procedure is sometimes referred to as system or sensor calibration.

Cartridge are supplied from the factory fully calibrated for the target gas, re-calibration at commissioning/start-up should not normally be required, However, if operating this product in accordance with EN50073:1999, or if local / national regulations require the cartridge to be calibrated this procedure should be followed. This procedure is also applicable if a cartridge requires re-calibration following a warning or fault message, or as part of routine maintenance

The calibration adjustments are carried out at the Transmitter Unit and gassing is performed at the Certified Sensor (this may be locally or remotely located).

The following equipment is required:

- **Flow Housing accessory (Part No: 2110B2140)** - fitted with rubber seal and supplied with loose hydrophobic filter
- **Test gas**
- **Regulator**

*Note: Zero gas and Span gas should be at roughly the same humidity levels to avoid erroneous cell responses.*

A hydrophobic filter is supplied loose with the Flow Housing which **must** be fitted when calibrating sensors with **flammable gas cartridges**.

When calibrating sensors fitted with **other cartridge types** then the filter mounted in the sensor cap for normal gas sensing operation (if one was used) should be fitted to the Flow Housing.

- (1) At the Certified Sensor remove the cap or accessory.

## 4. OPERATION

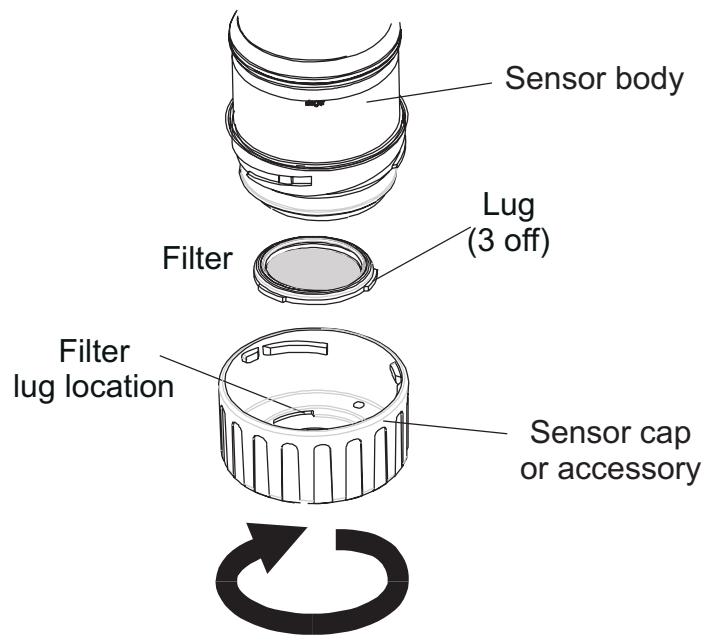

Rotate the cap/accessory in an anticlockwise direction by 1/4 turn to release the bayonet fitting and pull off.

- (2) If calibrating a sensor with a **non-flammable gas cartridge** remove the filter, if fitted, from the sensor cap/accessory and fit it to the Flow Housing. If fitted, the filter is held in place in the cap/accessory by its three lugs. Carefully prise the filter free from the lug location points in the cap or accessory.

If calibrating a sensor with a **flammable gas cartridge** fit the hydrophobic filter **supplied with the Flow Housing** into the housing.

In either case, to fit a filter into the Flow Housing, first remove the factory-fitted seal from the Flow Housing. The seal is held in place in the housing by its three lugs. Carefully prise the seal free from the lug location points in the housing.

The filter then locates in the Flow Housing in the same way as the removed seal. Ensure that the filter is placed in the Flow Housing the correct way round with the three lugs closest to the front face of the housing (where the gas pipes exit) and correctly engaged in the location points.

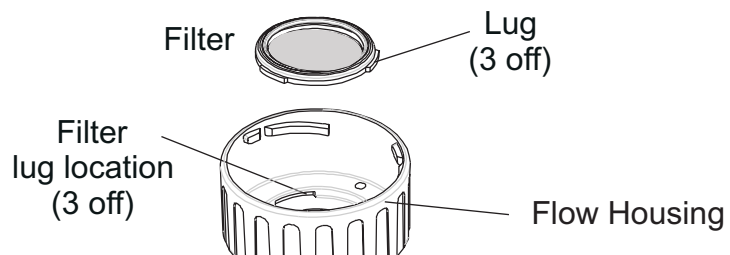

- (3) Fit the Flow Housing onto the Certified Sensor body.

## 4. OPERATION

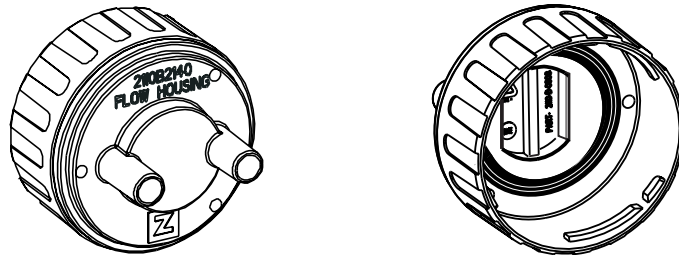

Reverse the cap removal procedure. The following diagram shows the Flow Housing accessory fitted to the Certified Sensor.

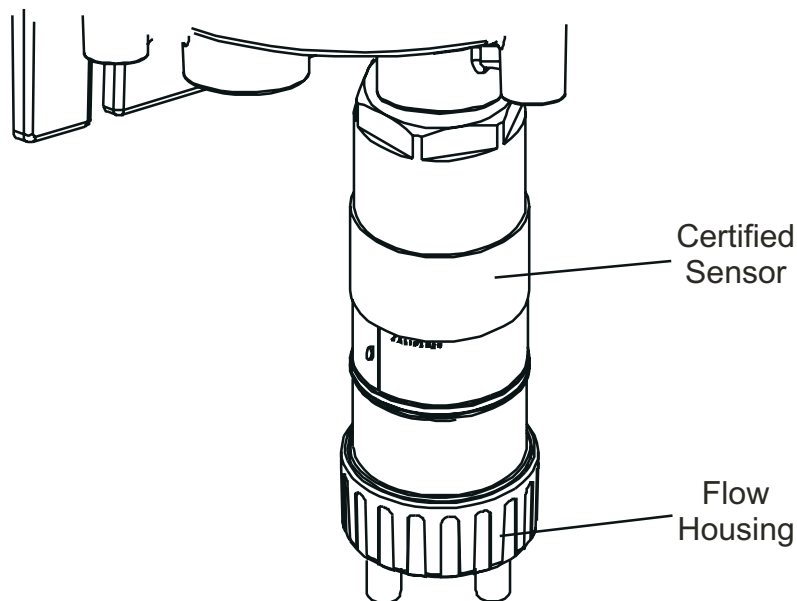

- (4) Press the **esc** button at the Transmitter Unit.  
*The Main Menu is displayed.*

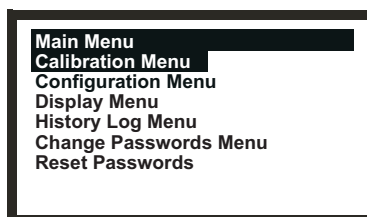

- (5) Navigate to the **Calibration Menu** option.  
*Use the up/down keys.*
- (6) Press **ok**.
- (7) Enter the current **Level 2** password.  
*The Calibration Menu is displayed.*

---

## 4. OPERATION

---

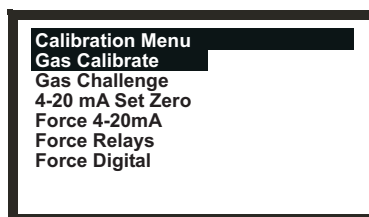

- (8) Navigate to the **Gas Calibrate** option.

*Use the up/down keys.*

- (9) Press **ok**.

*The **Zero Calibration** screen is displayed with the message:*

**Zero Gas then <OK>**

- (10) Ensure there is no gas present on the Certified Sensor.

*If gas is suspected to be in the vicinity of the sensor either check the area using a calibrated portable gas sensing device, e.g. Zellweger Analytic's Impact, or flow clean air over the Certified Sensor using the Flow Housing accessory .*

- (11) Press **ok**.

*The Transmitter Unit zeros the sensor. The LCD screen displays the message:*

**Calibrating - Wait**

*When successfully completed the LCD screen shows the message:*

**Success! OK:Continue**

- (12) Press **ok**.

*The **Span Calibration** screen is displayed with the message:*

**Calibrate? OK/ESC**

*This gives the choice to stop the calibration procedure at this point (after zero calibration) or continue to include the span and full gas calibration.*

- (13) Press **ok** to continue with **Span Calibration**.

*To skip the span calibration process, press the **esc** key.*

*Note: At this point, depending on the type of gas cartridge fitted to the sensor, a choice of two calibration gases may be displayed, e.g. C<sub>7</sub>H<sub>8</sub> has the options C<sub>7</sub>H<sub>8</sub> and CH<sub>4</sub> as choices. If so choose the one that will be used for calibration and press **ok**. Otherwise the process continues at the following step.*

- (14) Set the required test gas **Span Conc.** value.

*Use the up/down keys.*

---

## 4. OPERATION

---

- (15) Press **ok**.

*The LCD screen displays the message:*

**Apply Gas then <OK>**

- (16) Connect the Flow Housing (using either gas pipe) to the regulated cylinder containing a known concentration of the target gas at approximately the sensor alarm point, e.g. 50% LEL Methane in air.

*It is recommended for most sticky gases the tubing should be PTFE with short pieces of rubber tube to make the final connection due to the inflexibility of PTFE. This minimises adhesion of the gas to the tube surface and allows for more accurate measurement.*



### WARNING

As some test gases may be hazardous, the Flow Housing outlet should exhaust to a safe area.

- (17) Apply the target gas to the Certified Sensor.

*Pass the gas through the flow housing at a rate of between 0.7l/m and 1.0l/m. Wait for the gas reading to stabilise before continuing*

*Note: Certified Sensors should be calibrated at concentrations representative of those to be measured. It is always recommended that the Certified Sensor is calibrated with the target gas it is to detect.*

**Caution: Where the user calibrates any Certified Sensor using a different gas, responsibility for identifying and recording calibration rests with the user. Refer to the local regulations where appropriate.**

- (18) Press **ok**.

*The LCD screen displays the message:*

**Calibrating - Wait**

- (19) When calibration is successfully completed the message is displayed:

**Success! OK:Continue**

*Ensure that the sensor and the vicinity around it is clear all traces of the calibration gas before continuing. This is to avoid triggering spurious alarms.*

*If calibration fails at any point discard the cartridge and replace with a new one (see **Chapter 5**).*

- (20) Press **ok**.

*The **Calibration Menu** is displayed.*

---

## 4. OPERATION

---

- (21) Press the **esc** button twice.

*The **Main Menu** and then the **Gas Reading** screen is displayed.*

- (22) Remove the test equipment, refit the sensor cap to the sensor (with reinstalled filter if previously removed for the test) and return the system to normal operation (see 4.2).

### 4.8 BINDING COMMUNICATION BOARDS TO NETWORKS

This section describes how to carry out the configuration procedure necessary to bind a LonWorks Communications Board to the digital network. As the board forms part of the Transmitter Unit the component becomes a node on the network.

The procedure is necessary after fitting a LonWorks Communications Board to an Apex Transmitter Unit and connecting the digital network wiring (also see **Chapter 3**).

- (1) Power-up the Transmitter Unit.  
(2) Check that the Transmitter Unit completes its start-up sequence successfully.

*The **Gas Reading** should be displayed. Refer to 4.6 if an error message is displayed.*

- (3) Press the **esc** button on the front panel.

*The **Main Menu** is displayed.*

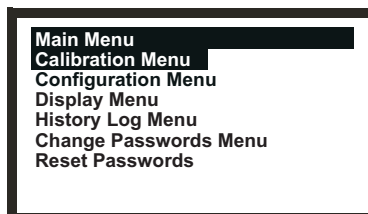

- (4) Select the **Configuration Menu** option.

*Use the **up/down** keys.*

- (5) Press the **enter** button.

- (6) Enter the current **Level 2** password.

*The **Configuration Menu** is displayed.*

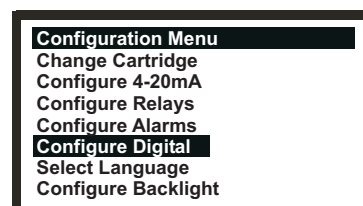

---

## 4. OPERATION

---

- (7) Select the **Configure Digital** option.
- (8) Press the **enter** button.

*The **Configure Digital** menu is shown displaying information similar to the following.*

<b>Configure Digital</b>	
<b>Network Type:</b>	<b>LonWorks</b>
<b>Connection Type:</b>	<b>FTT-10</b>
<b>Node Id:</b>	<b>00A176094800</b>
<b>Node Address:</b>	<b>N/A</b>
<b>Baud Rate:</b>	<b>78.0kbit/s</b>
<b>Node S/W Ver:</b>	<b>1.0</b>
<b>Assert Service Pin</b>	

*For a full explanation of the information see the **Configure Digital** menu option described earlier in this chapter.*

- (9) Select the **Assert Service PIN** option.

*Use the **up/down** keys.*

- (10) Press the **enter** button.

*This binds the node to the network controller.*

*The display automatically returns to the **Configuration Menu**.*

- (11) Press the **esc** button twice

*This returns to the **Gas Reading** display via the **Main Menu**.*



## 5. MAINTENANCE

The Apex system requires some routine maintenance.

This section provides information about the following:

- **Schedule for routine maintenance**
- **Procedures for routine maintenance/parts replacement**

### 5.1 ROUTINE MAINTENANCE SCHEDULE

The following table lists the recommended Apex system maintenance tasks and their frequency.

Sensor Type	Frequency	Maintenance Action	Equipment Required
<b>All models</b>	On overrange gas alarm	Calibrate the system (see Chapter 4). Replace the sensor cartridge if necessary.	Test gas, regulator, flow housing.
<b>All models</b>	On suspected exposure to contaminating gases	Calibrate the system (see Chapter 4). Replace the sensor cartridge if necessary.	Test gas, regulator, flow housing.
<b>All models</b>	3 monthly	Check the filters/cartridge face for cleanliness. Replace if required.	
<b>All models</b>	6 monthly	Calibrate the system (see Chapter 4).	Test gas, regulator, flow housing.
<b>Cl<sub>2</sub>, O<sub>2</sub>, and NH<sub>3</sub></b>	Annually	Replace the sensor cartridge if required.	
<b>H<sub>2</sub>S, CO</b>	2 yearly	Replace the sensor cartridge if required.	

*Note: No routine calibration is required for the Transmitter Unit or Certified Sensor electronics. Only the cartridge can be re-calibrated. This procedure is also sometimes referred to as system or sensor calibration.*

## 5. MAINTENANCE

### 5.2 MAINTENANCE PROCEDURES /PARTS REPLACEMENT

The following sections describe how to carry out the tasks listed in the maintenance schedule and how to replace parts suggested by **Fault Diagnosis** in **Chapter 4**. It tells how to change the following items:

- **Certified Sensor Filter**
- **Certified Sensor Cartridge**
- **Certified Sensor**
- **Transmitter Unit Front Panel Assembly**
- **CSA Transmitter Unit User Interface Cover Assembly**

#### 5.2.1 Changing the Certified Sensor Filter

The Certified Sensor filter is located in the sensor cap or accessory attached to the end of the sensor body. This procedure allows the filter to be safely changed with the unit powered-up.

*Note: Before starting the procedure check that the new filter is the correct type for the application. Three filter types are available: Mesh, Hydrophobic and Carbon (see **Chapter 2** and **Appendix C**).*

To replace the filter carry out the following procedure:

- (1) Remove the Certified Sensor cap or accessory from the sensor body.

*Rotate the cap or accessory in an anticlockwise direction by 1/4 turn to release the bayonet fitting and pull off.*

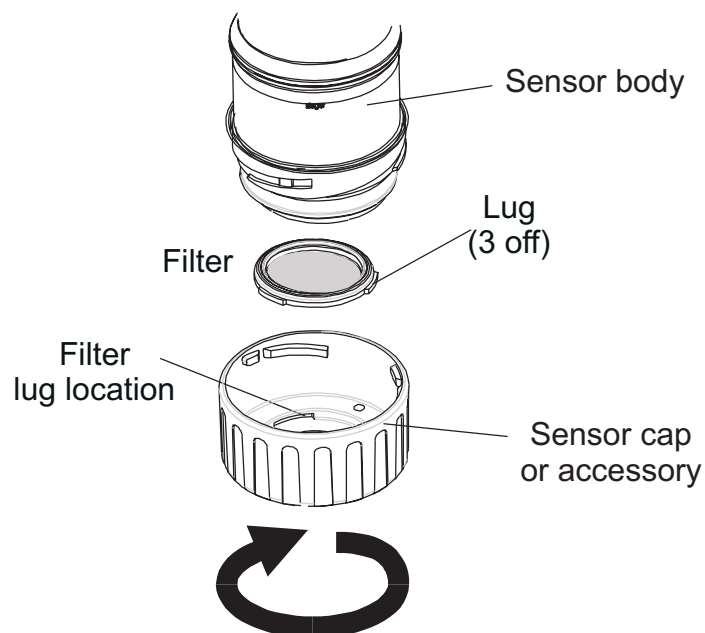

---

## 5. MAINTENANCE

---

- (2) Remove the existing filter.

*The filter is held in place in the cap by its three lugs. Carefully prise the filter free from the lug location points in the cap or accessory.*

- (3) Insert a new filter.

*Ensure that the filter is correctly placed in the cap the correct way round with the three lugs closest to the front face of the cap or accessory and correctly engaged in the location points.*

- (4) Refit the cap or accessory.

*Reverse the removal procedure.*

### 5.2.2 Changing the Certified Sensor Cartridge



#### WARNINGS

Change cartridges using the procedure described below. Failure to correctly follow this procedure could result in the wrong cartridge being installed, and possibly non-detection of events. Alternatively, extraneous alarms could be triggered by chemicals detected but not of concern at a particular location.

Sensor Cartridges may contain corrosive solutions. Dispose of according to local and national regulations.

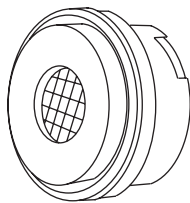

The Certified Sensor cartridge is located in the sensor body and protected by the cap or accessory. This procedure allows the cartridge to be safely changed with the unit powered-up.

Each cartridge is provided with a certificate of calibration (printed on the reverse of the instruction sheet, Part No: 2110M8015, supplied with the cartridge) that guarantees that the cartridge is calibrated and ready for use.

Before installing a cartridge check that the number on the cartridge label matches the gas type and range for the function required. A list of cartridges is given in **Appendix A**.

To replace a cartridge carry out the following procedure:

- (1) Press **esc** at the **Gas Reading** display.

*The Main Menu is displayed.*

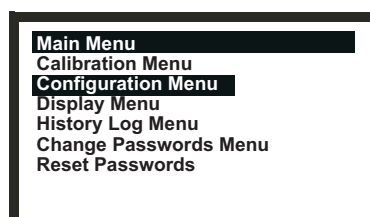

## 5. MAINTENANCE

- (2) Select **Configuration Menu** from the list.
- (3) Press **ok**.
- (4) Enter the current **Level 2** password.

*For information about passwords see Chapter 4.*

*The Configuration Menu is displayed.*

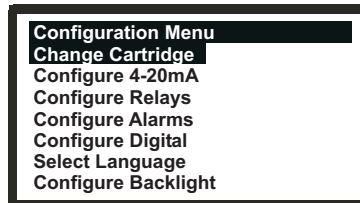

- (5) Select **Change Cartridge** from the menu list.
- (6) Press **ok**.

*The Change Cartridge screen is displayed.*

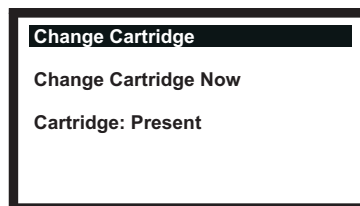

*Whilst this screen is showing, the cartridge can be safely replaced with the unit powered-up as follows.*

- (7) Remove the Certified Sensor cap or accessory from the sensor body.

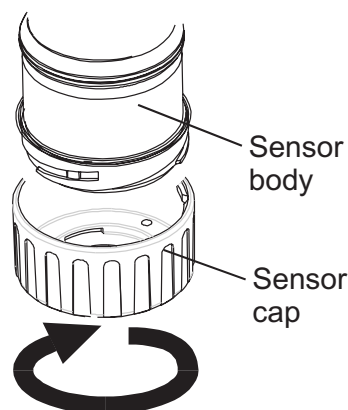

*Rotate the cap or accessory 1/4 turn in an anticlockwise direction to release the bayonet fitting.*

- (8) Remove the existing cartridge.

*The cartridge plugs into two sockets in the Certified Sensor body and is located by means of a tab.*

---

## 5. MAINTENANCE

---

To remove the cartridge without damaging it, grasp the visible part of the cartridge and pull it firmly straight out of the sensor body without twisting. Slight resistance is initially felt as the cartridge is pulled out of the electrical sockets.

Notes:

1. If replacing an Oxygen cartridge with another Oxygen cartridge ensure that the Oxygen Transducer Adaptor is left in place on the Certified Sensor body.

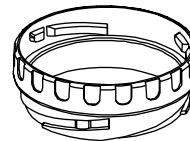

2. If replacing an Oxygen cartridge with a different type of cartridge ensure that the Oxygen Transducer Adaptor is removed from the sensor body.
3. If replacing a standard cartridge with an Oxygen cartridge ensure that the Oxygen Transducer Adaptor supplied with the Oxygen cartridge is fitted to the Certified Sensor body. The adaptor is fitted to the sensor body via a bayonet fitting.

The **Change Cartridge** screen now displays the following message.

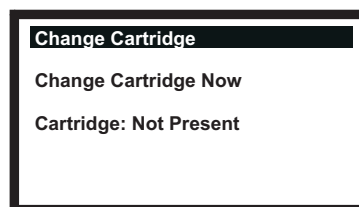

- (9) Fit the replacement cartridge.

**Caution:** Only cartridges with the following part numbers can be fitted to the Certified Sensor:

**2110B30x0, 31x0, 32x0, 33x0, 34x0 series**

**2110B3700 - 2110B3999 range**

Notes:

1. Certified to **CSA 22.2 No. 152** only when fitted with specific cartridges. See Specifications for details.

Carefully plug the cartridge into the Certified Sensor body ensuring that the cartridge tab lines up with the recess in the sensor body and push the cartridge, without twisting, until it is fully home.

## 5. MAINTENANCE

If the cartridge will not push fully home, re-check that the locating tab is correctly aligned with the recess in the sensor body. Position the tab so it is resting on the tab recess wall to the right or left of the tab recess and then turn the cartridge until the tab drops into the recess.

**Caution:** Do not force the cartridge as this may cause damage to the pins of the connecting plugs. Twisting and pushing can bend the pins and make the cartridge inoperative.

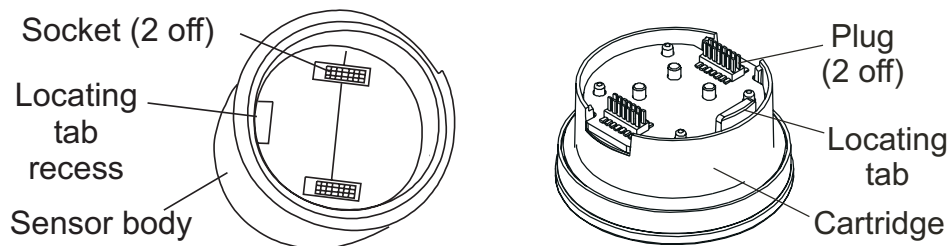

(10) Press **ok**.

The **Change Cartridge** screen now displays the following message.

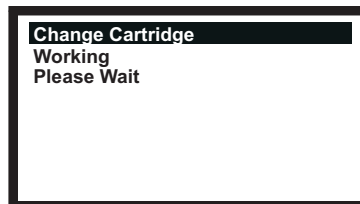

This screen is displayed while the cartridge is checked by the Transmitter Unit.

When the checks are completed successfully the following type of information about the new cartridge is displayed on the screen.

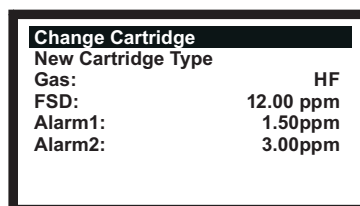

Check that the information displayed corresponds to the type of replacement cartridge fitted.

(11) Press **ok**.

The **Change Cartridge** screen now displays the following message.

---

## 5. MAINTENANCE

---

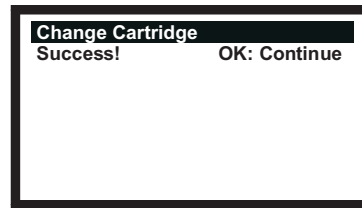

- (12) Press **ok**.

*The screen display returns to the **Configuration Menu**.*

- (13) Press **esc** twice.

*The screen returns to the **Gas Reading display**.*

- (14) Refit the cap or accessory to the Certified Sensor.

*Reverse the removal procedure.*

- (15) Check that the system is working correctly.

*Use the **Calibration Menu => Gas Challenge** menu option to check correct operation of the unit in the presence of the gas being sensed without triggering alarms, etc. (see **Chapter 4**).*

*Apply gas using a gas test module.*

- (16) Return the system to normal operation.

### 5.2.3 Changing the Certified Sensor

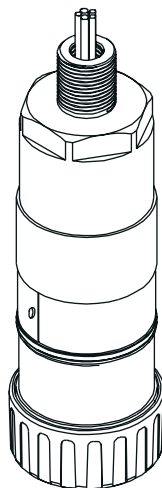

The Certified Sensor may be mounted in a Transmitter Unit or remotely in a Certified Junction Box. When replacing certified components also refer to the Control Drawings (see **Appendix B**).

To replace a Certified Sensor fitted to a Transmitter Unit or a Certified Junction Box carry out the following procedure:

**Caution:** *Ensure that the Transmitter Unit/Certified Junction Box flamepath is not damaged during this procedure. The flamepath is formed by the mating surfaces of the Transmitter Unit/Certified Junction Box top and base (see the component diagrams in Chapter 3).*

- (1) Isolate all associated power supplies and ensure that they remain **OFF** during this procedure. Ensure a gas free atmosphere.

## 5. MAINTENANCE

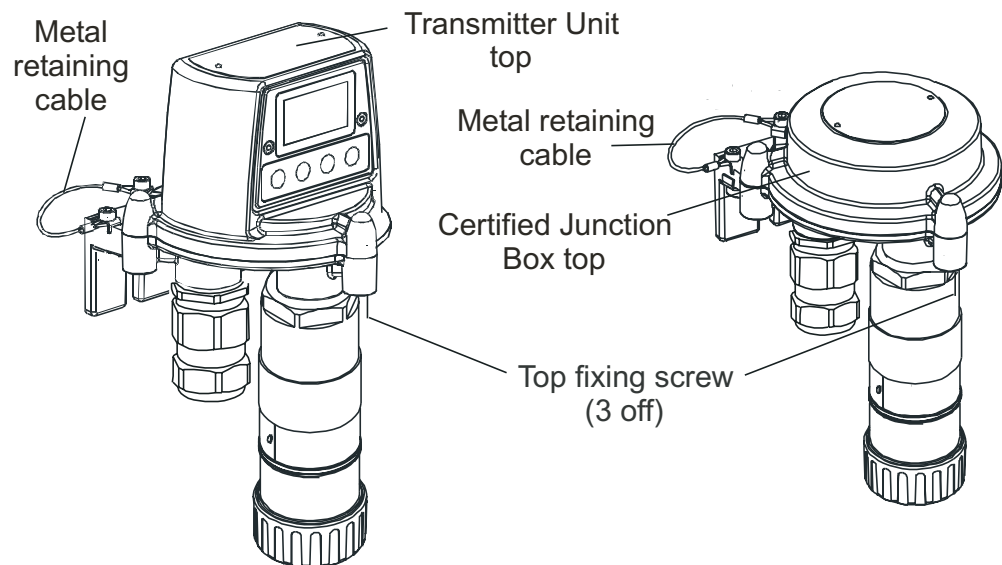

- (2) Detach the Transmitter Unit or Certified Junction Box top.

*Unscrew the three captive M8 hexagon key bolts underneath the base. Lift the top clear. For the Transmitter Unit only lift the top clear of the locating pins.*

*Caution: For the Transmitter Unit only take care not to damage or strain the ribbon cable connecting the lid and the Interconnect PCB in the base of the unit.*

- (3) For the Transmitter Unit support the top and ensure that it is supported whilst the next two steps are carried out.

*For the Certified Junction Box let the metal retaining cable, attaching the base and the top, hold the top, then go to Step (7).*

- (4) Unlatch the ribbon cable Zero Insertion Force (ZIF) connector on the Transmitter Unit Interconnect PCB.

*Grip the ends of the ZIF and pull it vertically upwards until it is felt to stop and the ribbon cable is loose. Refer to the Transmitter Unit installation component diagrams in **Chapter 3**.*

- (5) Pull the ribbon cable clear.

- (6) Remove the support from the Transmitter Unit top.

*Let the metal retaining cable, attaching the base and the top, hold the top.*

- (7) Disconnect the Certified Sensor wiring.

*Remove the wiring from the terminal blocks on the Interconnect PCB in the base of the Transmitter Unit or Certified Junction Box.*

*Record the location of the sensor wiring in the terminal blocks.*



---

## 5. MAINTENANCE

---

- (8) Unscrew the Certified Sensor from its mounting point.

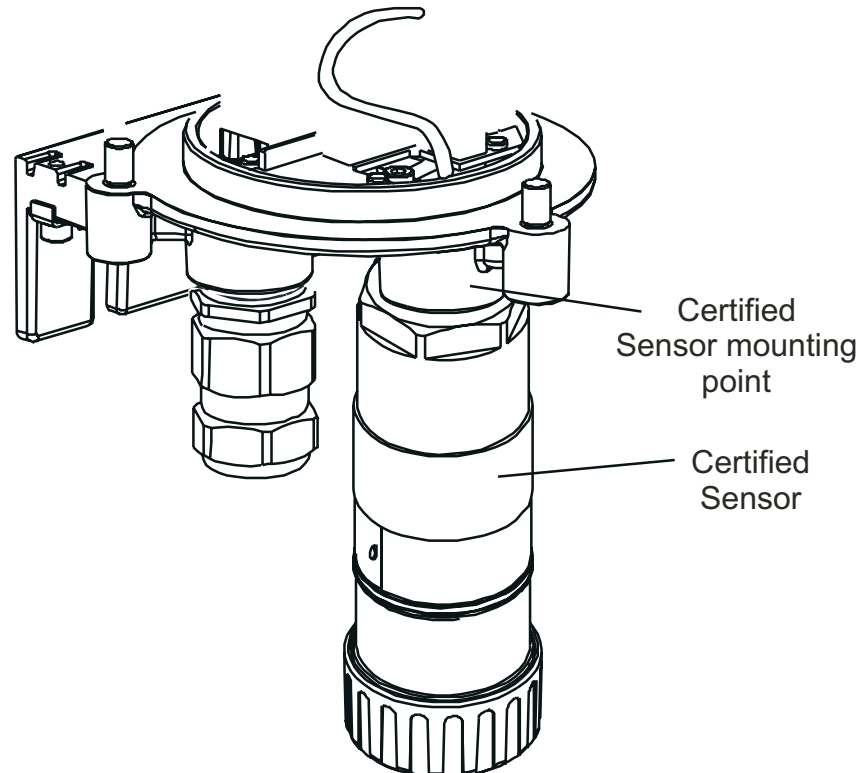

*The sensor unscrews in an anticlockwise direction. Feed the connecting cable out through the mounting point.*

- (9) Feed the cable from the replacement Certified Sensor in through the sensor mounting point.
- (10) Fit the replacement Certified Sensor.  
*Screw the threaded end of the replacement Certified Sensor firmly into the mounting point until it is fully home.*
- (11) Cut the sensor cable to the required length.
- (12) Connect the sensor wiring to the terminals.

*Refer to the wiring notes recorded in step 3 and to the diagram and wiring tables in Chapter 3.*

- (13) Refit the top to the Transmitter Unit or Certified Junction Box base.

**Cautions:**

- 1. Ensure that there is no moisture inside the unit before fitting the lid.**
- 2. Use only the captive bolts supplied, replacement with alternative bolts will invalidate certification.**
- 3. For the Transmitter Unit take care not to damage or strain the ribbon cable connecting the lid and the base.**

## 5. MAINTENANCE

*The Transmitter Unit top should be aligned using the locating pins on the base and then lowered onto the base. The Junction Box base does not have the locating pins.*

*Ensure that the lid retaining cable and/or wiring are not trapped and the O-ring in the top is correctly located. Check that there is no discernible gap between the top and the base.*

*Tighten the captive M8 bolts to 5Nm (3.68 foot-pounds).*

*Note: If the replacement sensor is to be fitted with the original gas sensing cartridge, then remove the cartridge from the replaced sensor and fit it to the new one following similar procedures to those in the sub-section 5.2.2.*

(14) Switch on all associated power supplies.

(15) Check that the system is working correctly.

*Use the **Calibration Menu => Gas Challenge** menu option to check correct operation of the unit in the presence of the gas being sensed without triggering alarms, etc. (see **Chapter 4**).*

*Apply gas using a gas test module.*

(16) Return the system to normal operation.

See **Chapter 4**.

### 5.2.4 Changing the Transmitter Unit Front Panel Assembly

This assembly may need to be replaced if the screen becomes damaged or the display and buttons do not operate correctly. One of the following two types of Front Panel Assembly may be fitted depending on the Transmitter Unit version:

- **CSA Transmitter Unit Front Panel Assembly**      **2110B2825**
- **All other versions**      **2110B2820**

The assembly is attached to the top of the Transmitter Unit by two screws.

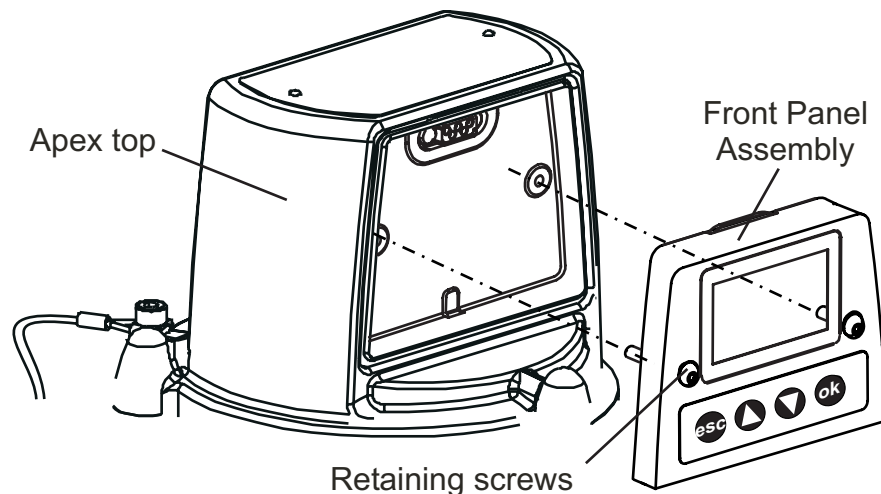

---

## 5. MAINTENANCE

---

To replace the assembly carry out the following procedure.

- (1) Isolate all associated power supplies and ensure that they remain **OFF** during this procedure. Ensure a gas free atmosphere.
- (2) Unscrew the two Front Panel Assembly retaining screws.  
*Use a hex-key tool to loosen the captive M4 screws.*
- (3) Pull the Front Panel Assembly forward away from the top.  
*Temporarily refit the M4 hex-key tool to one of the retaining screws and gently lever the assembly out of the recess in the top.*
- (4) Discard the removed Front Panel Assembly.
- (5) Place the replacement assembly into the recess in the top of the Transmitter Unit.
- (6) Secure the two retaining screws.  
*Tighten to 2.0Nm.*
- (7) Switch on all associated power supplies.
- (8) Check that the system is working correctly.  
*Ensure that the LCD screen is displaying a valid **Gas Reading** (see **Chapter 4**). Carry out a short random check of the menu system to ensure the front panel buttons are working correctly and the Transmitter Unit is responding and the LCD Screen is showing the correct information.*
- (9) Return the system to normal operation.

See **Chapter 4**.

---

# APPENDIX A - SPECIFICATIONS

---

This section of the handbook provides specification information about the following components:

- **Transmitter Unit**
- **Certified Sensor**
- **Cartridges**
- **Accessories**
- **LonWorks Communication Board**

## A.1 TRANSMITTER UNIT AND SENSOR

The Apex Transmitter Unit is designed to operate with the Certified Sensors specified in the tables later in this section. The Certified Sensors are designed so that they all have a common electrical interface to the Transmitters Unit. The cartridge data is digitised and processed into a gas reading by the Certified Sensor. The decision on whether gas alarms are present is also made within the Certified Sensor.

### A.1.1 Gases and Ranges

The Transmitter Unit with Certified Sensor can be fitted with any of the cartridges listed in the tables in section A.2.

### A.1.2 Input/Output

Power supply: +24VDC nominal (18-32V). Total power supply loop resistance should be less than 30 ohms with ECC cartridge, 16 ohms with Catalytic cartridge.

Power consumption: Relays active - 3.6W ECC cartridge, 5.6W Catalytic cartridge.

Relays: Three relays: A1, A2 and Fault.  
Contact rating: 100mA (min), 2A (max) at 30Vdc non-inductive except UL/CSA where specification is +28VDC 1A.

Single pole change-over type connected to two terminals:

- one terminal connected to the relay common
- one terminal connected via a user configurable link to either the relay contact normally open or normally closed.

# APPENDIX A - SPECIFICATIONS

Relays are user configurable to be normally energised or normally de-energised.

Relays are user configurable to be latching or non-latching. Latched relays can be reset by the keypad, by the digital communications link (optional) or by the removal of power.

Default settings	A1	A2	Fault
Default coil state	de-energised	de-energised	energised
Default latch state	non-latching	non-latching	non-latching
Default terminal	normally open	normally open	normally open

Digital I/O standards:	Optional. LonWorks
Display:	LCD.  Information displayed: gas reading, state (OK, fault, inhibit, warning, A1, A2, Overrange), fault/warning codes, Certified Sensor type and diagnostic data.
Display language:	Default language: English. The user can select from a set of built-in languages: French, German, Italian, Spanish.
Keypad/user I/O:	Four keys (escape, up, down, ok) for calibration, configuration, relay de-latching, display of status information, acceptance of new Certified Sensor types, basic testing of output functions (digital bus test, 4-20mA test).
4-20mA output:	3-wire sink or source, 4-wire, isolated. Range 0-22mA. Zero point adjustable in the range 4mA ± 0.5mA (default 4mA). Upper current limited to 22mA. Loop resistance 0-300 ohms (with a 24V loop supply).
Fault:	0mA nominal (0-0.5mA)
Inhibit:	1mA default (user configurable 1-4mA)
Warning:	User selectable. Either a fixed level (3mA default, userconfigurable between 1-4mA), a pulsed current or disabled.  When the unit is in the warning state a gas reading can still be calculated.

---

# APPENDIX A - SPECIFICATIONS

---

If the value of this increases beyond 50% of the first alarm level the 4-20mA output reverts to indicating the gas reading.

If subsequently the reading decreases below 25% of the first alarm level the 4-20mA reverts to indicating the warning state.

Over Range: 21mA

Caution: When compliance with the ATEX EN50054 performance standard is required the warning and inhibit current shall not be configured to a value between than 3.1mA and 4.9mA.

Note: For Oxygen sensors, the output is arranged so that 4mA corresponds to 0% V/V, and 20mA corresponds to 25% V/V. The overrange state can be configured as either latching or non-latching. The default is non-latching.

Terminal sizes: Field wiring terminals accept 2.5mm<sup>2</sup> conductors.

## A.1.3 Monitoring functions

Maintains a record of power ups in the Transmitter Unit.

Maintains a time-stamped record of faults, warnings and alarms in the Transmitter Unit (history log).

## A.1.4 Performance

Transmitter Unit and Certified Sensor without cartridge.

Accuracy: ± 1% FSD -25 to 55°C (-13 to 131°F)

Baseline drift: ± 0.5% FSD over three months

Span drift: ± 0.5% FSD over three months

Baseline vs temperature ± 1% FSD -40 to 65°C (-40 to 149°F)

Span vs temp ± 1% FSD -25 to 55°C (-13 to 131°F)

Speed of response: <0.5s between a step input and a corresponding change in the output.

Digital electronics and software meet the requirements of EN50271:2002, Electrical apparatus for the detection and measurement of combustible gases, toxic gases or oxygen – Requirements and tests for apparatus using software and/or digital technologies.

*Note: For performance specification of complete Apex transmitter + Sensor + Cartridge refer to section A.2 or data sheet for cartridge*

## A.1.5 Environmental

Operating temperature: -40 to 65°C (-40 to 149°F)

User Interface: -20 to 65°C (-4 to 149°F)

Operating humidity: 0-99%rh

## A.1.6 Storage (excluding cartridge)

Temperature: -40 to 65°C (-40 to 149°F)

Humidity: 0-99%rh

---

# APPENDIX A - SPECIFICATIONS

---

## A.1.7 EMC

Meets the requirements of EN 50270:1999 (type 2 apparatus), EMC - Electrical Apparatus for the Detection and Measurement of Combustible Gases, Toxic Gases or Oxygen.

## A.1.8 Enclosure

Physical:

The Transmitter Unit has:

One threaded hole in the base for mounting the Certified Sensor - M20 (European) or 3/4" NPT (North American versions)

Two threaded holes in the base to accept two certified M25 cable glands (European) or two 3/4" NPT conduit fittings (North American versions).

Provision is made to attach a tag carrying an ID number.

The enclosure materials for Apex are electro-polished grade 316 stainless steel (to BS3146 ANC 4B FM/BS3146 ANC 4C FM) and Zinc Alloy.

Size:

140mm wide x 150mm high x 152mm deep.

Weight:

4000gm.

Mountings:

Provision for two M10 bolts, centres 68mm apart.

Ingress Protection  
(Transmitter Unit with  
Certified Sensor fitted)

IP67 to BS EN 60529:1992, Degrees of protection provided by enclosures (IP code).

## A.1.9 Configuration

The Transmitter Unit can be configured during installation and operation to accept any of the Certified Sensors it is compatible with (see the gas/cartridge tables in section A.2).

## A.1.10 Certification and Approvals

### Hazardous Area Certifications

#### *Transmitter Unit:*

**ATEX:**

Approvals by EXAM

Assessment of performance to EN50054, EN50057 and EN50271

Operating temperature range: -40 to +65°C  
Certificate No: BVS03ATEXG012X

Approvals by EECS (BASEEFA)

⊕ II 2 G D EEx d ia IIC

Operating temperature codes:

T135°C (Tamb -40 to +80°C)

T100°C (Tamb -40 to +55°C)

Certification Number: BAS01ATEX2433

---

## APPENDIX A - SPECIFICATIONS

---

**UL:** Approvals by UL  
Class I, Division 1, Groups B, C, D  
Class I, Zone 1, AEx d [ia] IIC  
Operating temperature codes:  
T4 (Tamb -40 to +80°C)  
T5 (Tamb -40 to +55°C)

**CSA:** Approvals by CSA  
Class I, Division 1, Groups B, C, D  
T4 (Tamb -40 to +75°C)  
T5 (Tamb -40 to +55°C)

Transmitter Unit Certified to **CSA C22.2 No. 152** only when Certified Sensor is fitted with specific cartridges. See A.2 Cartridges, Flammable SG16 - US/Rest of the world version (page 108 ).

***Certified Sensor:***

**ATEX:** Approvals by EXAM  
Assesment of performance to EN50054,  
EN50057 and EN50271  
Operating temperature range: -40 to +65°C  
Certificate No: BVS03ATEXG012X  
Approvals by EECS (BASEEFA)  
Ⓔ II 2 G D EEx d ia IIC  
Operating temperature codes:  
T135°C (Tamb -40 to +80°C)  
T100°C (Tamb -40 to +55°C)  
Certification Number: BAS01ATEX2435X

**UL:** Approvals by UL  
Class I, Division 1, Groups B, C, D  
Class I, Zone 1, AEx d [ia] IIC  
Operating temperature codes:  
T4 (Tamb -40 to +80°C)  
T5 (Tamb -40 to +55°C)

**CSA:** Approvals by CSA  
Class I, Division 1, Groups B, C, D  
T4 (Tamb -40 to +75°C)  
T5 (Tamb -40 to +55°C)

Certified Sensor approved to **CSA C22.2 No. 152** only when fitted with specific cartridges. See A.2 Cartridges, Flammable SG16 - US/Rest of the world version (page 108).



---

# APPENDIX A - SPECIFICATIONS

---

## CE Marking

Complies with EU directives 89/336/EEC and 93/68/EEC (Electromagnetic Compatibility).

Complies with EN 50270:1999, EMC - Electrical Apparatus for the Detection and Measurement of Combustible Gases, Toxic Gases or Oxygen

Complies with EU directive 94/9/EC (ATEX) for use in Hazardous Areas.

### A.1.11 Calibration intervals

Cartridge dependent. There is no routine calibration of the Transmitter Unit or Certified Sensor electronics.

## A.2 CARTRIDGES

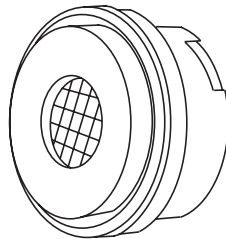

The Certified Sensor can be fitted with any one of a number of interchangeable cartridges. Each replaceable cartridge contains a gas sensing transducer and its calibration/manufacturing information. It is possible to replace the cartridge without removing the power from the Certified Sensor, even in hazardous environments.

Four types of cartridge are available:

- **electrochemical cell**
- **catalytic (SG16 type)**
- **Oxygen**
- **thick film**

### A.2.1 Cartridge tables

This section provides a summary list of the cartridges that can be fitted to the Certified Sensor.

*Notes:*

1. *Consult Zellweger Analytics for cartridge availability.*
2. *For cartridge specifications see the data sheet supplied with each cartridge.*

# APPENDIX A - SPECIFICATIONS

## Toxic - Electrochemical cell

Gas Part No:	Range	
Ammonia	50ppm	2110B3320
Ammonia	100ppm	2110B3330
Ammonia	400ppm	2110B3340
Ammonia	1000ppm	2110B3350
Arsine	0.2ppm	2110B3000
Boron trichloride	4ppm	2110B3020
Bromine	0.4ppm	2110B3040
Carbon monoxide	100ppm	2110B3140
Carbon monoxide	200ppm	2110B3150
Carbon monoxide	500ppm	2110B3160
Chlorine	2ppm	2110B3090
Chlorine	5ppm	2110B3100
Chlorine	15ppm	2110B3110
Chlorine dioxide	0.4ppm	2110B3130
Diborane	0.4ppm	2110B3010
Dichlorosilane	10ppm	2110B3430
Ethylene oxide	4ppm	2110B3050
Fluorine	4ppm	2110B3200
Germane	0.8ppm	2110B3210
Hydrogen	1000ppm	2110B3220
Hydrogen bromide	12ppm	2110B3270
Hydrogen chloride	20ppm	2110B3280
Hydrogen cyanide	20ppm	2110B3290
Hydrogen fluoride	12ppm	2110B3300
Hydrogen sulfide	15ppm	2110B3530
Hydrogen selenide	0.2ppm	2110B3260
Hydrogen sulfide	20ppm	2110B3230
Hydrogen sulfide	50ppm	2110B3240
Hydrogen sulfide	100ppm	2110B3250
Nitric oxide (NO)	100ppm	2110B3360
Nitrogen dioxide	12ppm	2110B3370
Oxygen	21%V/V	2110B3380
Phosphine	1.2ppm	2110B3400
Propylene Oxide	8ppm	2110B3070
Silane	2ppm	2110B3490
Silane	20ppm	2110B3440
Sulfur dioxide	8ppm	2110B3460
Sulfur dioxide	15ppm	2110B3470
Sulfur dioxide	50ppm	2110B3520
Tetraethyl orthosilicate (TEOS)	40ppm	2110B3450

# APPENDIX A - SPECIFICATIONS

## Flammable - Catalytic SG16 - European version

Calibrated to the %LEL levels specified by EN61779-1:2

Gas Part No:	Range	
1* (see note)	100%LEL	2110B3910
2* (see note)	100%LEL	2110B3911
3* (see note)	100%LEL	2110B3912
4* (see note)	100%LEL	2110B3913
5*	100%LEL	2110B3914
6*	100%LEL	2110B3915
7*	100%LEL	2110B3916
8*	100%LEL	2110B3917
Acetone	100%LEL	2110B3721
Butane	100%LEL	2110B3702
Ethanol	100%LEL	2110B3712
Ethylene (see note)	10% LEL	2110B3787
Ethylene	100%LEL	2110B3708
Hexane	100%LEL	2110B3717
Hydrogen	100%LEL	2110B3707
LPG	100%LEL	2110B3705
Methane <sup>1</sup>	100%LEL	2110B3704
Methanol	100%LEL	2110B3723
Octane (see note)	100%LEL	2110B3719
Propane <sup>1</sup>	100%LEL	2110B3701
Propene	100%LEL	2110B3703
Styrene	100%LEL	2110B3727
Toluene	100%LEL	2110B3728

<sup>1</sup> Performance assessed to EN50054 and EN50057. Ref Section A.2.2.

*Note: Cartridge **must** be used with Apex revised Certified Sensor Part Nos:*

**ATEX 2110B2070**

**UL 2110B2073**

**CSA 2110B2074**

# APPENDIX A - SPECIFICATIONS

## Flammable - Catalytic SG16 - US/Rest of the world version

Calibrated to the %LEL levels specified by CSA/EN50054

Gas Part No:	Range	
1 <sup>2</sup> (see note)	100%LEL	2110B3930
2 <sup>2</sup> (see note)	100%LEL	2110B3931
3 <sup>2</sup> (see note)	100%LEL	2110B3932
4 <sup>2</sup> (see note)	100%LEL	2110B3933
5 <sup>2</sup>	100%LEL	2110B3934
6 <sup>2</sup>	100%LEL	2110B3935
7 <sup>2</sup>	100%LEL	2110B3936
8 <sup>2</sup>	100%LEL	2110B3937
Butane <sup>2</sup>	100%LEL	2110B3752
Butyl acetate <sup>2</sup> (see note)	100%LEL	2110B3772
Ethylene <sup>2</sup>	100%LEL	2110B3758
Hexane <sup>2</sup>	100%LEL	2110B3767
Hydrogen <sup>2</sup>	100%LEL	2110B3757
Methane <sup>2</sup>	100%LEL	2110B3754
Propane <sup>2</sup>	100%LEL	2110B3751
Toluene <sup>2</sup>	100%LEL	2110B3778

<sup>2</sup> Evaluated to CSA C22.2 No.152.

*Note: Cartridge **must** be used with Apex revised Certified Sensor Part Nos:*

**ATEX 2110B2070**

**UL 2110B2073**

**CSA 2110B2074**

## Flammable and toxic - Thick film

Gas	Range	Part No:
Ammonia	100ppm	2110B3800
Hydrogen Sulfide	50ppm	2110B3802

---

### A.2.2 Catalytic SG16 cartridges, Methane and Propane

Range:	2110B3701 - Propane, 0 to 100%LEL. 100%LEL eq. 1.7%V/V) 2110B3704 - Methane, 0 to 100%LEL. (100%LEL eq. 4.4%V/V)
Operating Temperature Range:	-40 to +65°C
Temperature Effects:	2110B3704 – Methane, Better than +/-5% LEL 2110B3701 – Propane, +/-6%LEL
Operating Humidity Range:	5%rH to 90%rH (99%rH Intermittent – non-condensing.)
Humidity Effects:	Better than +/-5% LEL.
Operating Pressure Range:	80kPa to 110kPa
Pressure Effects:	Better than +/-5% LEL.
Warm-up Time:	30s (typical). 900s (worst case).
Response Time:	2110B3701 – Propane, T <sub>50</sub> 8s, T <sub>90</sub> 17s. (typical) 2110B3704 – Methane, T <sub>50</sub> 6s, T <sub>90</sub> 11s. (typical) <i>(When fitted with standard sensor cap and no filter.)</i>
Linearity:	Better than +/-5% LEL or +/-10% reading, whichever is the greater.
Accuracy/Repeatability:	Better than +/-3% LEL
Stability with Time (3 months):	2110B3704 – Methane, Better than +/-5% LEL 2110B3701 – Propane, +/-6%LEL

---

---

Permitted Accessories:	Standard sensor cap, plus either, no filter or Mesh filter. Weather housing, plus either, no filter, Mesh filter, or Hydrophobic filter. <i>(Response Time will be increased when using the Weather Housing and either the Mesh or Hydrophobic Filters)</i>  Collecting Cone, plus either, no filter or Mesh filter. Sun Shade (These accessories have not been evaluated to EN50054/57.)
Calibration Gas Concentration:	25%LEL to 105%LEL
Alarm Threshold Limits:	15%LEL to 100%LEL (Alarm 1 and Alarm 2)
Poisoning:	The cartridge may become inactive after extensive exposure to silicones, halogenated hydrocarbons, heavy metals or sulfur compounds.
Oxygen Deficiency:	Depletion of Oxygen as a consequence of displacement by flammable gas can result in the gas reading returning to zero.
Storage Conditions:	0 to 25 °C 30% to 70% rH 80kPa to 110kPa

---

# APPENDIX A - SPECIFICATIONS

---

## A.3 ACCESSORIES

This sub-section provides the specifications for each of the accessories available for Apex.

### A.3.1 Certified Junction Box

The Certified Junction Box provides a remote mounting point for the sensor. It is designed to operate with the sensor cartridges specified in the tables in this section.

#### Environmental

Operating temperature: -40 to 65°C (-40 to 149°F)

Operating humidity: 0-99%rh

#### Storage (excluding cartridge)

Temperature: -40 to 65°C (-40 to 149°F)

Humidity: 0-99%rh

#### EMC

Meets the requirements of EN 50270:1999 (type 2 apparatus), EMC - Electrical Apparatus for the Detection and Measurement of Combustible Gases, Toxic Gases or Oxygen.

#### Enclosure

Physical: The Certified Junction Box has:  
One threaded hole in the base for mounting the Certified Sensor - M20 (European) or 1/2" NPT (North American versions)  
Two threaded holes in the base to accept two certified M25 cable glands (European) or two 1/2" NPT conduit fittings (North American versions).  
Provision is made to attach a tag carrying an ID number.  
The enclosure material for the Certified Junction Box is electro-polished grade 316 stainless steel (to BS3146 ANC 4B FM/BS3146 ANC 4C FM).

Size: 140mm wide x 95mm high x 152mm deep.

Weight: 3000gm.

Mountings: Provision for two M10 bolts, centres 68mm apart.

#### Configuration

The Certified Junction Box can be configured during installation and operation to accept any of the Certified Sensors it is compatible with (see the gas/cartridge tables in section A.2).

---

# APPENDIX A - SPECIFICATIONS

---

## Certification and Approvals

### Hazardous Area Certifications

<b>ATEX:</b>	Approvals by EECS (BASEEFA)  ⊕ II 2 G D EEx d IIC T100° (Tamb -40 to +80°C) T135° (Tamb -40 to +55°C)  Certification Number: BAS01ATEX2434
<b>UL:</b>	Approvals by UL  Class I, Division 1, Groups B, C, D Class I, Zone 1, AEx d IIC T4° (Tamb -40 to +80°C) T5° (Tamb -40 to +55°C)
<b>CSA:</b>	Approvals by CSA  Class I, Division 1, Groups B, C, D T4° (Tamb -40 to +75°C) T5° (Tamb -40 to +55°C)

Junction Box certified to CSA 22.2 No. 152 only when certified sensor is fitted with specific cartridges. See A.2 Cartridges, Flammable SG16 - US/Rest of the world version (page 108)

The performance of this accessory has not yet been evaluated to EN50054/57.

### CE Marking

Complies with EU directives 89/336/EEC and 93/68/EEC (Electromagnetic Compatibility).

Complies with EN 50270:1999, EMC - Electrical Apparatus for the Detection and Measurement of Combustible Gases, Toxic Gases or Oxygen

Complies with EU directive 94/9/EC (ATEX) for use in Hazardous Areas.

### A.3.2 Sunshade

Material:	Loaded stainless steel.
Size:	145mm high x 115mm wide.
Weight:	110gm.

Conforms to CSA 22.2 No.152 when fitted to the Certified Sensor with specific cartridges installed. See specifications for detail.



---

## APPENDIX A - SPECIFICATIONS

---

### A.3.3 Flow Housing

Material:	Fortron®: PPS (modified Polyphenylene sulphide)
Size:	43mm high x 53mm diameter.
Weight:	26gm.

Conforms to **CSA 22.2 No. 152** when fitted to the Certified Sensor with specific cartridges installed. See specifications for detail.

### A.3.4 Weather Protection

Material:	Fortron®: PPS (modified Polyphenylene sulphide)
Size:	75mm high x 53mm diameter.
Weight:	60gm.

Conforms to **CSA 22.2 No. 152** when fitted to the Certified Sensor with specific cartridges installed. See specifications for detail.

### A.3.5 Collecting Cone

Material:	Fortron®: PPS (modified Polyphenylene sulphide)
Size:	127mm high x 160mm wide.
Weight:	120gm.

Conforms to **CSA 22.2 No. 152** when fitted to the Certified Sensor with specific cartridges installed. See specifications for detail.

The performance of this accessory has not yet been evaluated to EN50054/57.

### A.3.6 Oxygen Transducer Adaptor

Material:	Fortron®: PPS (modified Polyphenylene sulphide)
Size:	18mm high x 53mm diameter.
Weight:	8gm.

## A.4 LONWORKS COMMUNICATIONS BOARD

When fitted to a Transmitter Unit the LonWorks communications board provides an interface between the unit and an open LON standard network.

The board consists of a Neuron micro-processor and associated memory and logic interface components. Isolation to the network and correct signal levels are provided by an FTT-10A transceiver device.

# APPENDIX A - SPECIFICATIONS

## A.4.1 LonWorks Network Variables

The *LIFELINE II* gas detector has fourteen Network variable outputs, two network variable inputs and four network configuration inputs as shown in the following LonMark Object Diagram.

Some or all of these may be bound to a LonWorks network. Descriptions of each variable are given in the subsequent sub-sections. For more information consult Zellweger Analytics.

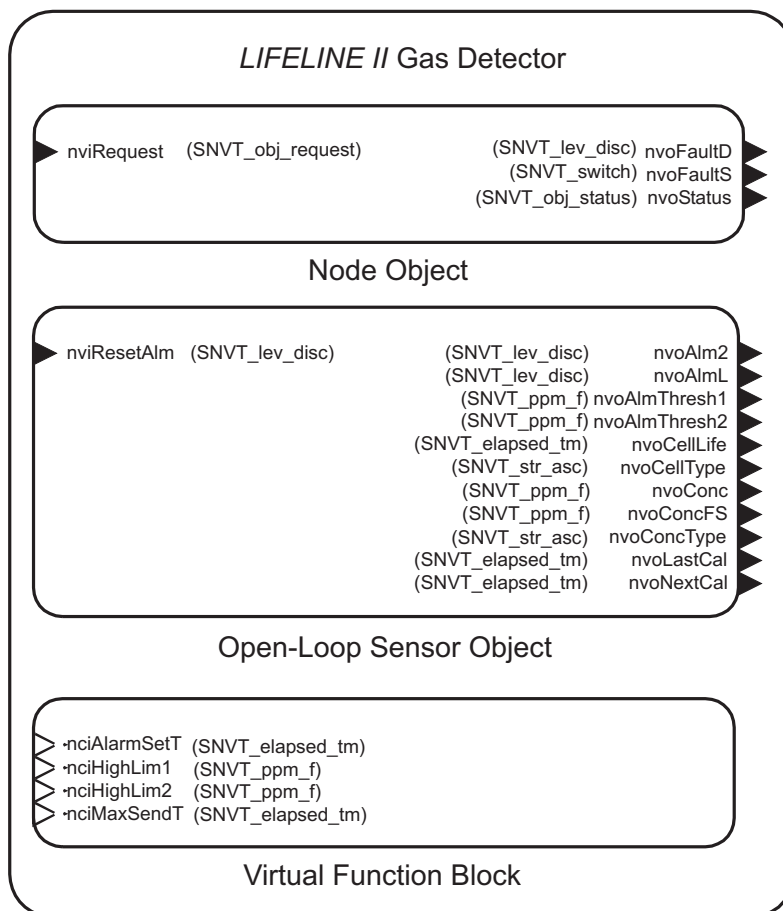

LonMark Object Diagram

## A.4.2 Node Object

The Node object has one network variable input and three network variable outputs.

### nviRequest input and nvoStatus output

The Node object implements SNVTs for object request and status. These complex variables are required for LonMark compatibility and are capable of conveying a great deal of information between the instrument and a Graphical user Interface (GUI) computer or a network management tool but are less appropriate for peer-to-peer communications.

# APPENDIX A - SPECIFICATIONS

It is possible to disable the sensor, reset alarms and perform other functions using `nviRequest`. The complete list of commands is in the subsequent table.

Furthermore, `nvoStatus` reports information about the sensor in a compact format such as when an alarm or fault is present. The complete usage of `nvoStatus` is listed in the table at the end of this section.

## **nvoFaultD output**

This simple variable of type `SNVT_lev_disc` can be bound to common LonWorks relays to activate lights or perform shutdown. This normally has the value `ST_OFF`. If maintenance is needed soon (for example because the cartridge is near the end of its life) then this variable will have the value `ST_LOW`.

If a serious fault exists that compromises the ability to detect gas then this variable will have the value `ST_MED`.

## **nvoFaultS output**

This variable containing two one-byte fields is more complex than `nvoFaultD`. `nvoFaultS.state` normally is 0 but will have the value 1 if the sensor has any fault or warning.

If `nvoFaultS.state` is true then `nvoFaultS.value` will have an error number to facilitate preliminary diagnosis over the network. Note that Echelon's LNS applications display the `.value` field divided by two.

<b>nvoFaultS .value</b>	<b>Transmitter Code</b>	<b>Cause</b>
2	1	Watchdog Restart Occurred
8	4	Momentary Cartridge Failure
10	5	Temperature Warning
12	6	Approaching End of Cell Life
14	7	Calibration Needed Soon
42	21	Sensor Failed
44	22	No Cartridge
46	23	Wrong Cartridge
48	24	Cartridge Failed
50	25	Temperature Error
52	26	End of Cell Life
54	27	Calibration Required
62	31	Transmitter Alarm Setting Failure
64	32	Sensor Comms Failed
102	51	Fatal Fault
202	101	Transmitter Failed
204	102	Transmitter Failed
226	113	Transmitter Failed

---

# APPENDIX A - SPECIFICATIONS

---

## A.4.3 Sensor Object

The sensor object has one network variable input and eleven network variable outputs.

### **nviResetAlm input**

This network variable causes latching alarms and faults to be reset. The reset will only take place if the cause of the fault or alarm no longer exists. Additionally, the reset only occurs when a non-zero update is sent to this input.

This means that sending an *ST\_LOW* to this input once will not have any effect on alarms or faults that occur later. This input resets both the local relays and LonWorks network variables.

### **nvoAlmL output**

This network variable normally has the value *ST\_OFF*. When a level 1 alarm exists the *alarm1* relay will be activated and this output will have the value *ST\_LOW*.

When a level 2 alarm exists the *alarm2* relay will be activated and this will produce *ST\_MED*.

### **nvoAlm2 output**

This variable normally has the value *ST\_OFF*. When a level 2 alarm exists this will have the value *ST\_MED*.

This network variable is provide for use with common shutdown relays that are not capable of discriminating between *ST\_LOW* and *ST\_MED* in installations where discrimination between *alarm1* and *alarm2* is desired.

### **nvoAlarmThresh1 and nvoAlarmThresh2 outputs**

These network variables indicate the current alarm thresholds of this instrument. Gas concentrations greater than the amount reported in these variables will cause the alarms to activate. See the related subsequent discussion of *nviHighLim1* and *nviHighLim2*.

The units are the same as the front panel display and will be indicated by *nvoConcType*, below. The units will be *ppm*, *%LEL* and *%VIV* respectively when gas sensor cartridges for toxic, explosive and oxygen gasses are installed.

For example if an H<sub>2</sub> cartridge is installed and *nvoAlarmThresh1* is **50.00**, this means that *alarm1* will activate when the H<sub>2</sub> concentrations exceeds **20,000 ppm** since LEL for H<sub>2</sub> is **40,000 ppm**.

### **nvoCellLife output**

This variable reports the total cell life remaining. This is cell type specific, but is typically set for new cartridges at **2 years** of service. It is reported in hours of life.

---

# APPENDIX A - SPECIFICATIONS

---

## **NvoNextCal output**

This variable reports when the next calibration is required. The default is **6 months** of service between calibrations. It is reported in hours (interval starts at **4320hrs** and counts to **zero**).

## **nvoLastCal output**

This variable indicates the **time since last calibration**, counting back from **current time**.

## **nvoCellType output**

This string contains the name of the gas that the installed cartridge is capable of detecting. It is the same string that appears on the front panel of the transmitter. For example **CO** or **HF**. This has a **5** character maximum.

## **nvoConc output**

This is the gas concentration as a floating point number. The units are the same as *nvoAlarmThresh1*, see above.

## **nvoConcFS output**

This floating point number reports the maximum concentration that the installed sensor is capable of measuring. The units are the same as *nvoAlarmThresh1*, see above.

## **nvoConcType output**

This string contains the measurement units for the installed cartridge. Possible values include *ppm*, *%VIV* and *%LEL*.

### **A.4.4 Virtual Function Block**

The four network configuration inputs appear in a *virtual* functional block in Echelon LonMaker3.

## **nciMaxSendT input**

This controls the time period between updates of bound but unchanging network variable outputs. The default is **20** seconds but this can be changed from **1** to **59** seconds depending on installation-specific needs.

## **nciAlarmSetT input**

Reporting of alarm events over LonWorks may be delayed by up to **59** seconds by setting this parameter to a **non-zero** value. However this has no effect on alarm reporting over the analog current loop or the local relays.

This is included to suppress ephemeral alarm events which may be caused by fluctuations in temperature, pressure, or humidity or by strong radio-frequency interference. The default value of **zero** is recommended for most applications.

# APPENDIX A - SPECIFICATIONS

## nciHighLim1 and nciHighLim2 inputs

These network configuration inputs (NCIs) set the alarm thresholds for the sensor. LonMaker automatically loads these from a configuration parameter database when a *replace* or *resynchronise* operation is performed.

However, updates to these NCIs will have no effect if they contain an illegal value. Additionally, the actual alarm thresholds (which are indicated by *nvoAlmThresh1* and *nvoAlmThresh2*) may differ if changed using the front-panel user interface.

So setting the sensor alarm thresholds is intuitive using either these two NCIs or the front panel. But mixing the two strategies can be cumbersome. The units are the same as *nvoAlarmThresh1*, see above.

## A.4.5 Implementation of nviRequest

The *object request* variable can convey a variety of commands to LonWorks nodes. Not all of these messages are applicable to the *LIFELINE II*.

The following table lists which of these requests are implemented. Blank entries correspond to unimplemented requests.

Request	Node Implementation
0 RQ_NORMAL	Enable concentration and alarm reporting
1 RQ_DISABLED	Disable concentration and alarm reporting via LonWorks
2 RQ_UPDATE_STATUS	Re-propagate nvoConc and alarms
3 RQ_SELF_TEST	
4 RQ_UPDATE_ALARM	Update alarm status, over-rides AlarmSetTime
5 RQ_REPORT_MASK	Notify of request mask implementation
6 RQ_OVERRIDE	
7 RQ_ENABLE	Concentration and alarm reporting enabled.
8 RQ_RMV_OVERRIDE	
9 RQ_CLEAR_STATUS	
10 RQ_CLEAR_ALARM	Reset latched alarm
11 RQ_ALARM_NOTIFY_ENABLE	Enable Alarm reporting
12 RQ_ALARM_NOTIFY_DISABLE	Disable Alarm reporting via LonWorks
13 RQ_MANUAL_CTRL	
14 RQ_REMOTE_CTRL	
15 RQ_PROGRAM	

# APPENDIX A - SPECIFICATIONS

## A.4.6 Interpretation of nvoStatus

The *object status* contains a great deal of information about the status of a node. Several bits have meaning assigned which is specific to Zellweger Analytics.

For example *fault\_alert* (Zellweger nomenclature) has been mapped to *mechanical\_fault* (LonMark nomenclature).

The following table lists all of these assignments. Blank entries correspond to unimplemented status bits.

Status Field	Node 0 interpretation
object_id (16 bits)	0
invalid_id	object_id>1
invalid_request	Unimplemented request made
disabled	Network reporting inhibited
out_of_limits	Warning alert active
open_circuit	
out_of_service	Not in normal mode
mechanical_fault	Fault alert active
feedback_failure	
over_range	Concentration > full scale
under_range	
electrical_fault	
unable_to_measure	Sensor is not connected
comm_failure	Error inside <i>LIFELINE II</i>
fail_self_test	Error inside <i>LIFELINE II</i>
self_test_in_progress	
locked_out	Remote access unavailable
manual_control	
in_alarm	Alarm level 1 is active
in_override	
report_mask	nvoStatus mask report
programming_mode	
programming_fail	Request made could not be implemented
alarm_notify_disable	Alarm reporting over network is disabled.





---

# APPENDIX B - CERTIFICATION

---

## CSA

CLASS I, DIV 1, GROUPS B, C, D

OP. TEMP CODE T4 (Tamb. -40 to +75°C)

T5 (Tamb. -40 to +55°C)

*Note: Transmitter Unit certified to **CSA 22.2 No. 152** only when certified sensor is fitted with specific cartridges. See B.5 Control Drawings, CSA (page 126)*

## B.2 CERTIFIED SENSOR

The Certified Sensor is designed and approved for use in hazardous areas.

There are six certified sensor types:

### Sensor - ECC/Catalytic

- **ATEX** Part No: 2110B2000 or 2110B2070
- **UL** Part No: 2110B2003 or 2110B2073
- **CSA** Part No: 2110B2004 or 2110B2074

### Sensor - Thick Film

- **ATEX** Part No: 2110B2010 or 2110B2010
- **UL** Part No: 2110B2013 or 2110B2013
- **CSA** Part No: 2110B2014 or 2110B2014

The UL/CSA Certified Sensor is suitable for connection to an Apex Transmitter Unit or an Apex/Matrix Junction Box.

**Caution: Only cartridges with the following part numbers can be fitted to the Certified Sensor:**

**2110B30x0, 31x0, 32x0, 33x0, 34x0 series**  
**2110B3700 - 2110B3999 range**

Certified Sensor approved to **CSA 22.2 No. 152** only when fitted with specific cartridges. See B.5 Control Drawings, CSA (page 126)

A certification label is located on the body of the Certified Sensor. The label contains all the relevant information regarding the product's identification and certification state.

# APPENDIX B - CERTIFICATION

## ATEX

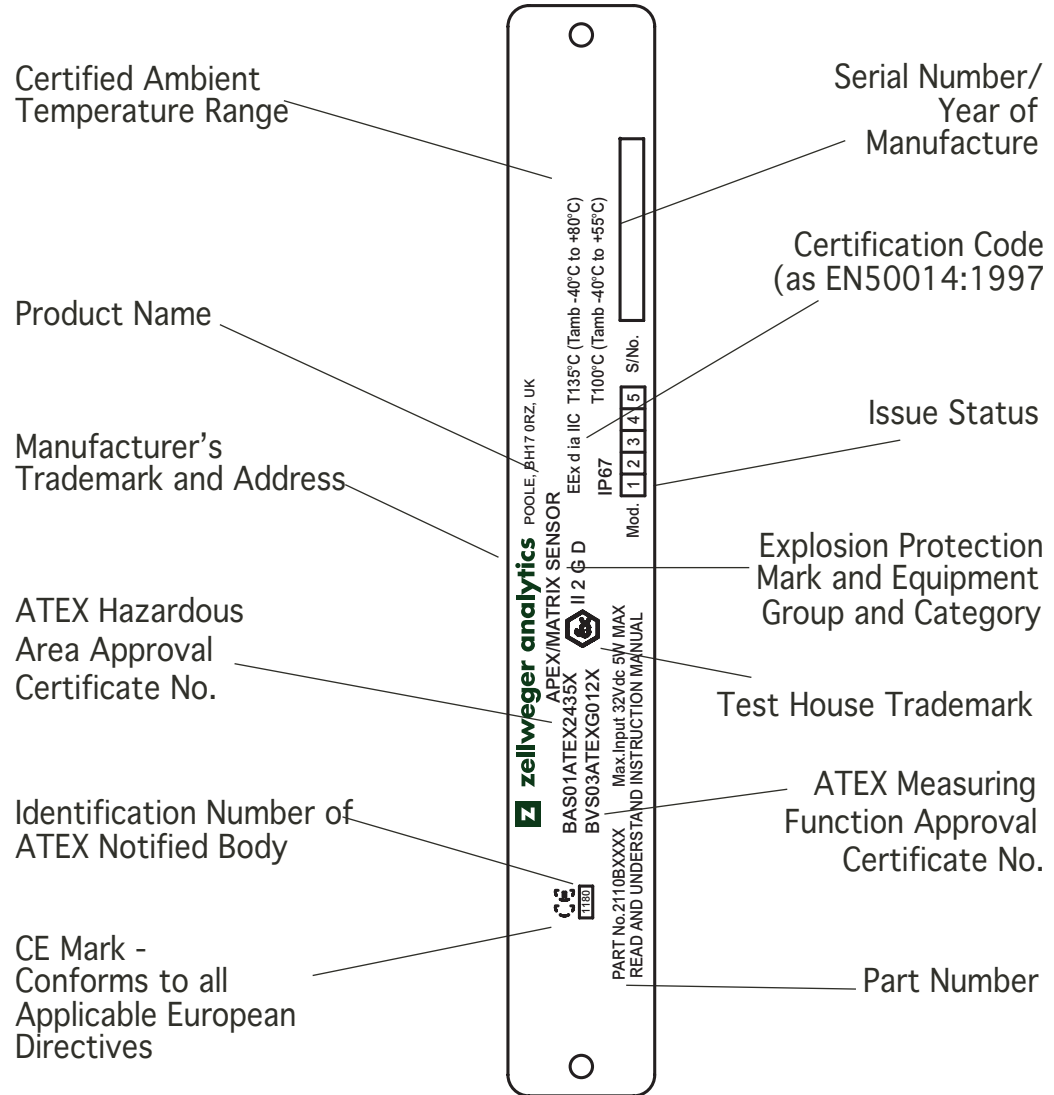

## UL

APEX/MATRIX SENSOR:

CLASS I, DIV 1, GROUPS B, C, D

CLASS I, ZONE 1 AEx d [ia] IIC

OP. TEMP CODE T4 (Tamb. -40 to +80°C)

T5 (Tamb. -40 to +55°C)







# APPENDIX B - CERTIFICATION

## CSA

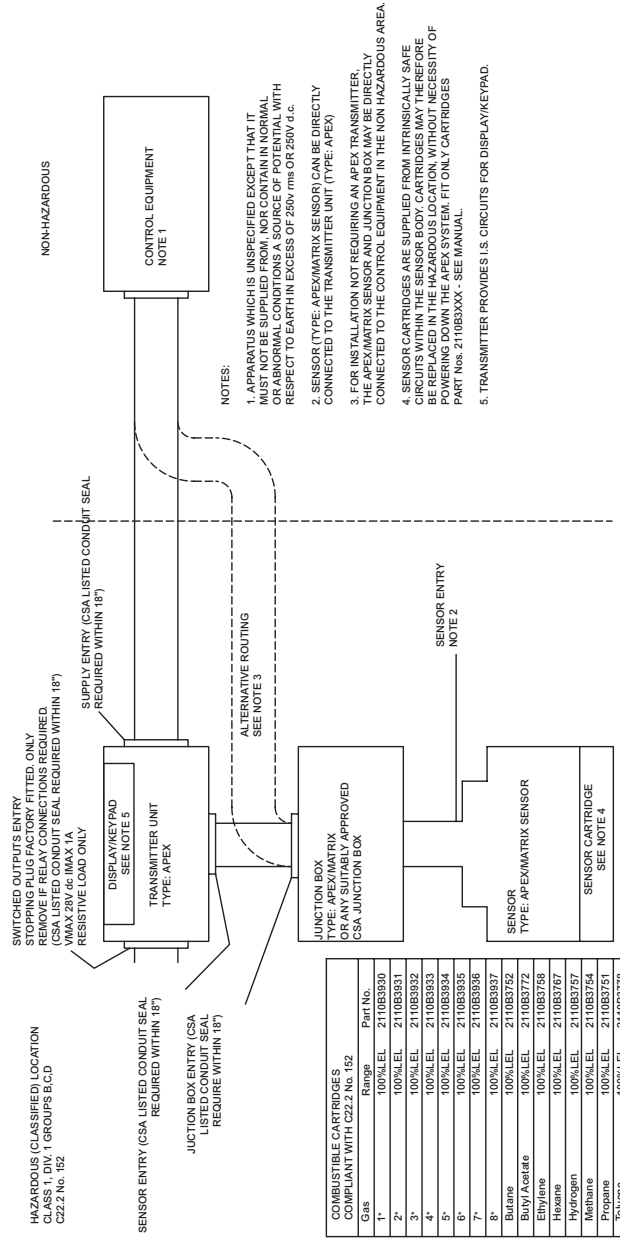

# APPENDIX C - ACCESSORIES & SPARE PARTS

This appendix lists the accessories and spare parts available for the Apex system.

## C.1 ACCESSORIES

Description	Part Number
Certified Junction Box for remote Certified Sensor mounting:	
ATEX EExd	2110B2100
UL/CSA	2110B2103
Collecting Cone	2110B2151
Flow Housing	2110B2140
Sunshade	2110B2152
Weather Protection	2110B2150

## C.2 DIGITAL COMMUNICATIONS BOARD

Description	Part Number
LonWorks digital communications board	2110B2600

## C.3 SPARES

Description	Part Number
Carbon filter	2110B2172
Hydrophobic filter	2110B2171
Mesh filter	2110B2170
Sensor cap	2110B2800
Transmitter Unit Front Panel Assembly	2110B2820
CSA Transmitter Unit Front Panel Assembly	2110B2825
Transmitter Unit Screw and Gasket Set	2110B2829

Note: The filter and sensor cap spares include the required rubber seal.

---

# APPENDIX D - GLOSSARY

---

## **BASEEFA**

British Approvals Service for Electrical Equipment in Flammable Atmospheres. A service run by the EECS (Electrical Equipment Certification Service). Part of the UK Health and Safety Executive.

## **Cartridge**

A replaceable assembly containing a gas transducer and associated calibration information.

## **Catalytic Bead**

Used for the detection of combustible gases. These are made of an electrically heated platinum wire coil, covered first with a ceramic base and then with a final outer coating of catalyst.

## **CE mark**

Indicates compliance to all relevant European directives.

## **CSA**

CSA International, the Canadian Standards Authority.

## **Certification (Hazardous area)**

This is the approval needed for equipment that is used in those areas that are formally classified as 'hazardous'. The approval is given following product assessment by an independent body. The assessment is to verify that the product conforms to the published standards for hazardous area equipment.

## **Electrochemical Sensor**

A gas sensitive electrode, formed by a permeable membrane and special electrolyte.

## **EXAM BBG Pruef- und Zertifizier GmbH**

German approvals service for electrical equipment in flammable atmospheres and for the measuring performance of gas detection apparatus.

## **Gas Transducer**

An element that translates gas concentration into an electrically measurable quantity, such as electrochemical cells, catalytic beads and thick film devices.

## **Hazardous Area**

A formally identified and classified area where there is a risk of explosion. Equipment for use in hazardous areas must carry the required certification. All areas outside the hazardous areas are deemed to be 'safe areas'.



---

## APPENDIX D - GLOSSARY

---

### **LCD**

Liquid Crystal Display.

### **LEL**

Lower Explosive Limit – is the lowest concentration of 'fuel' in air which will burn and for most flammable gases and vapours it is less than 5% by volume.

Note: for some gases (e.g. methane) the LEL level has different values in the European and North American standards.

### **LEL%**

Percentage of the Lower Explosive Limit (for example, 10% LEL of methane is approximately 0.5% by volume).

### **LON**

Local Operating Network.

### **PCB**

Printed circuit board.

### **Peak**

Maximum, or minimum, measurement since switch on.

### **PPB**

Parts per billion concentrations in the atmosphere.

### **PPM**

Parts per million concentrations in the atmosphere.

### **rh**

Relative humidity.

### **Sensor**

A gas transducer within a protective enclosure: sensors may be safe or hazardous area mounted, and may also include some driving, interfacing, biasing or signal conditioning circuitry.

### **Transmitter**

A field device that is locally connected to a gas sensing transducer that translates the raw sensor output into a user useful form, e.g. a display, 4-20mA or digital output.

---

## APPENDIX D - GLOSSARY

---

### **UEL**

Upper Explosive Limit.

### **UL**

Underwriters Laboratories Inc. US-based standards and approvals organisation.

### **%VOL**

Concentration of explosive gas, measured in percentage by volume.

### **%V/V**

Another way of representing %VOL

**Find out more**

[www.honeywellanalytics.com](http://www.honeywellanalytics.com)

**Customer business centre**

**Europe and the rest of the world**

Honeywell Analytics AG

Wilstrasse 11-U11

CH-8610 Uster

Switzerland

Tel: +41 (0)44 943 4300

Fax: +41 (0)44 943 4398

[sales@zelana.co.uk](mailto:sales@zelana.co.uk)

**Customer business center**

**Americas**

Honeywell Analytics Distribution, Inc.

400 Sawgrass Corporate Pkwy

Suite 100

Sunrise, FL 33325

USA

Tel: +1 954 514 2700

Toll free: +1 800 538 0363

Fax: +1 954 514 2784

[sales@zelana.com](mailto:sales@zelana.com)

[www.honeywell.com](http://www.honeywell.com)

Issue 04 12/2005

H\_MAN0604\_V1

2110M8030

© 2005 Honeywell Analytic

**Honeywell**