



Moisture Target™ Series 6

Moisture analyzer

Features

- Low-cost, single-channel hygrometer for OEM applications
- M Series moisture probe or VeriDri moisture transmitter compatible
- NEMA 4 weatherproof membrane front display/keypad
- Built-in isolated current or voltage analog output
- MicroSD card for logging data up to 32 GB
- Panel-mount and board-level configurations
- Fail-safe fault alarm relay
- Two Form C measurement alarm relays
- Upgrades from MTS5 with adapter face plate

Applications

This single-channel analyzer measures moisture in compressed air and gases. Designed for permanent installations, it is used in conjunction with M Series moisture probe or VeriDri moisture transmitter for air/gas dryer original equipment manufacturer (OEM) applications:

- Regenerative desiccant air or gas dryers
- Plastic drying applications prior to injection blow molding
- Medical air dryers
- Glove box monitoring

Low cost, real-time moisture measurement

The Moisture Target Series 6 is an economical, single channel, aluminum oxide hygrometer in the Moisture Series line of analyzers. It is intended for OEM applications requiring low-cost, accurate, real-time moisture measurement.

Improves OEM product performance

The Moisture Target Series 6 can significantly enhance the performance of OEM products by allowing closed-loop control of moisture. For example, in a regenerative dryer application it can improve efficiency by initiating desiccant bed regeneration when needed, rather than on an open-loop timed cycle.

Panel-mount

The panel-mount Moisture Target Series 6 comes in a compact DIN standard meter housing for applications where space is at a premium. The case slides directly into the panel cutout, and is held in place from the rear by captive screws.

The Moisture Target Series 6 can be supplied with a bezel adaptor to allow installation into existing Moisture Target Series 5 panel cut-outs.

Uses M series probes and VeriDri transmitter

The Moisture Target Series 6 uses M Series aluminum oxide moisture sensor probe or VeriDri moisture transmitter. M Series probes and VeriDri transmitter are rugged and accurate true absolute humidity sensors with calibration traceable to NIST. Exceptional dynamic range, speed of response and calibration stability have made the aluminum oxide sensor the standard for performance and value in industrial moisture measurement for more than 40 years.



Microprocessor-based electronics

The microprocessor-based Moisture Target Series 6 accurately tracks fast-changing process conditions and displays dew/frost point temperature in °F or °C on an LCD. Dew/frost point is also available as an analog voltage or current output, and the Moisture Target Series 6 features built-in isolation to ensure the integrity of signals to remote devices. The unit also features two Form C alarm relays for high and low dew/frost point limits. The microprocessor-based electronics and six-button keypad combine to make selection of analog output zero and span, alarm setpoints fast and easy, and entry of calibration data simple.

Series 6 specifications

Electronics

Intrinsic safety

External safety barrier for moisture input (optional)

European compliance

Complies with EMC directive 2004/108/EC and 2006/95/EC low voltage directive (Installation category II, pollution degree II)

Input

Moisture signal from Baker Hughes Sensing thin-film aluminum oxide moisture sensor on an M Series probe or VeriDri transmitter

Analog output

Single internal isolated recorder output for dew point, internally optically isolated, 10-bit (0.1%) resolution

Standard switch-selectable outputs

- 0 to 2 V, 10k W minimum load resistance
- 0 to 20 mA, 400 W maximum series resistance
- 4 to 20 mA, 400 W maximum series resistance
- User-programmable within the range of the instrument and the corresponding sensor or transmitter

Alarm relays

- One fail-safe fault relay
- Two standard Form C relays SPDT, rated for 3 A at 250 VAC/30 VDC
- Set to any level within the range of the instrument; programmable from the front panel

Alarm set point repeatability

$\pm 0.2^{\circ}\text{F}$ ($\pm 0.1^{\circ}\text{C}$) dew point

Datalogger

32 GB capacity with MicroSD card, 2 GB card included

Display

128 x 64 matrix LCD

Display functions

Dew point temperature in $^{\circ}\text{F}$, $^{\circ}\text{C}$ or sensor signals for diagnostics

Power requirements

Universal power 100–240 VAC @ 50–60 Hz, or 24 VDC nominal

Temperature

- Operating: -4° to 140°F (-20° to 60°C)
- Storage: -40° to 158°F (-40° to 70°C)

Warm-up time

Meets specified accuracy within three minutes

Configurations

- Panel (front panel meets Type 4 and IP66)
- Board version, without enclosure

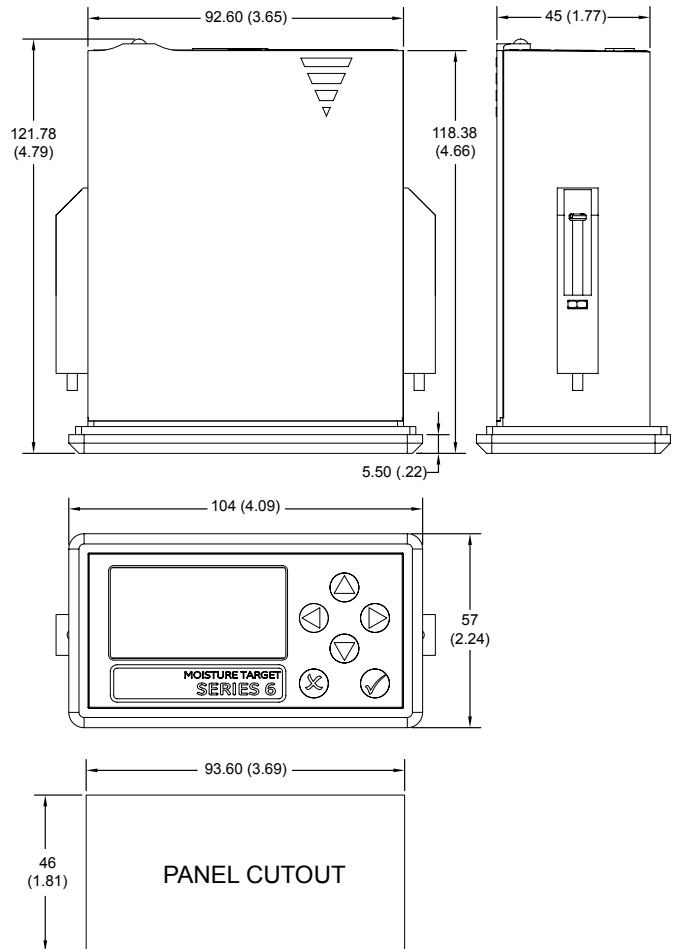

Series 6 specifications

Moisture measurement

Sensor type

Thin-film aluminum oxide

Moisture probe compatibility

Compatible with all Baker Hughes M Series aluminum oxide moisture probes and VeriDri transmitters

Dew/frost point temperature

- Overall range capability: 140°F to -166°F (60°C to -110°C)
 - Standard 68°F to -112°F (20°C to -80°C) with data to -166°F (-110°C)
 - Extended 140°F to -85°F (60°C to -80°C) with data to 166°F (-110°C)
- VeriDri ranges include:
 - -110°C to 20°C
 - -110°C to -50°C
 - -90°C to 10°C
 - -80°C to -30°C
 - -80°C to 20°C
 - -30°C to 20°C
 - -130°F to 70°F
 - -130°F to -40°F
 - -40°F to 70°F
 - -50°F to 50°F
 - -100°F to 0°F

Calibrated accuracy at 77°F (25°C)

- $\pm 3.6^\circ\text{F}$ ($\pm 2^\circ\text{C}$) from -85°F to 50°F (-65°C to 10°C)
- $\pm 5.4^\circ\text{F}$ ($\pm 3^\circ\text{C}$) from -112°F to -86°F (-80°C to -66°C)

Repeatability

- $\pm 0.9^\circ\text{F}$ ($\pm 0.5^\circ\text{C}$) from -85°F to 50°F (-65°C to 10°C) dew/frost point
- $\pm 1.8^\circ\text{F}$ ($\pm 1.0^\circ\text{C}$) from -112°F to -86°F (-80°C to -66°C) dew/frost point

Panametrics, a Baker Hughes Business, provides solutions in the toughest applications and environments for moisture, oxygen, liquid and gas flow measurement. Experts in flare management, Panametrics technology also reduces flare emissions and optimizes performance.

With a reach that extends across the globe, Panametrics' critical measurement solutions and flare emissions management are enabling customers to drive efficiency and achieve carbon reduction targets across critical industries including: Oil & Gas; Energy; Healthcare; Water and Wastewater; Chemical Processing; Food & Beverage and many others.

Join the conversation and follow us on LinkedIn
[linkedin.com/company/panametricscompany](https://www.linkedin.com/company/panametricscompany)

