

Installation and operating instructions

UFM 600 T ALTOSONIC

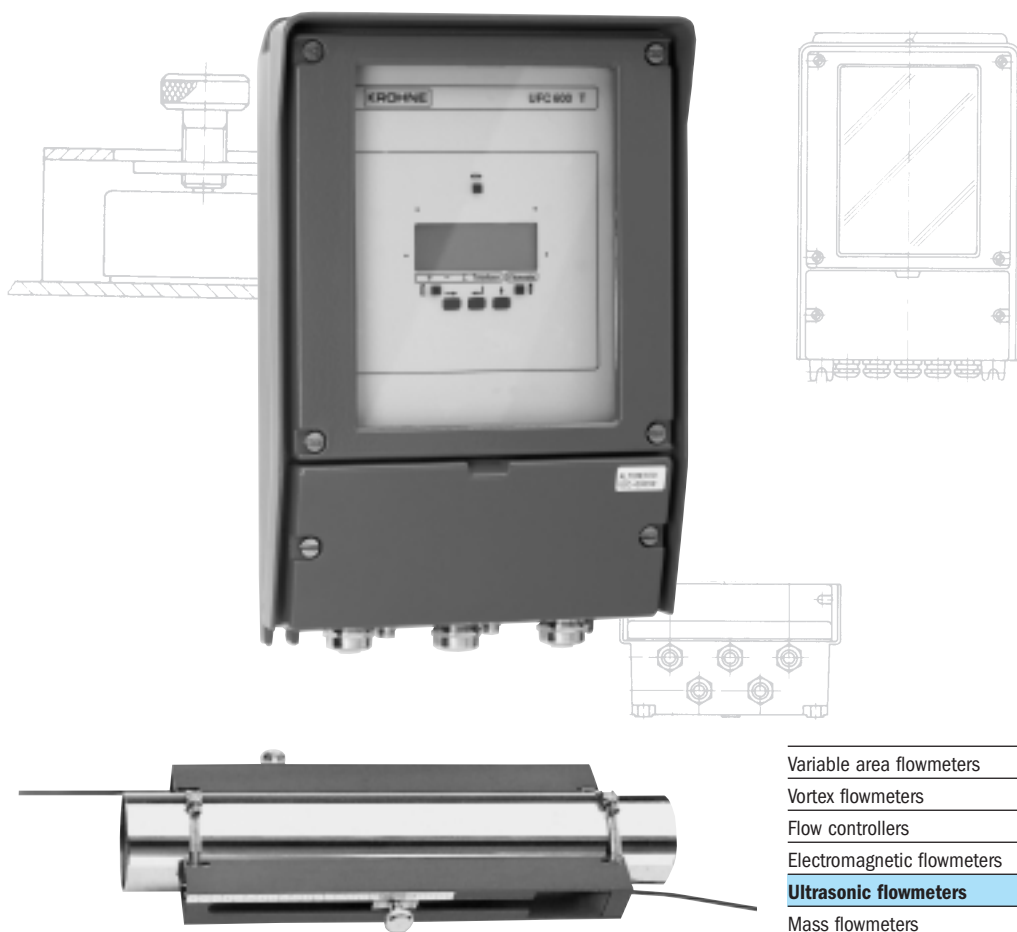

Variable area flowmeters

Vortex flowmeters

Flow controllers

Electromagnetic flowmeters

Ultrasonic flowmeters

Mass flowmeters

Level measuring instruments

Communications engineering

Engineering systems & solutions

Switches, counters, displays and recorders

Heat metering

Pressure and temperature

All rights reserved. No part of this publication may be copied or published by means of printing, photocopying, microfilm or otherwise without prior written consent of KROHNE Altometer.

This restriction also applies to the corresponding drawings and diagrams.

KROHNE Altometer has the right to change the parts or specifications at any time without prior or direct notice to the client. The contents of this publication are subject to change without notice.

This publication is to be used for the standard version only. Thus KROHNE Altometer cannot be held responsible for any damage resulting from the incorrect application of this publication to the version actually delivered to you.

For additional information regarding configuration, maintenance and repair, contact the technical department of your supplier.

This publication has been written with great care. However, KROHNE Altometer cannot be held responsible, either for any errors occurring in this publication or their consequences.

ALTOSONIC Contents

UFM 600 T

A	INTRODUCTION	6
B	SYSTEM DESCRIPTION	8
B.1	Measuring Principle	8
B.2	Measuring System	10
B.3	Equipment	12
B.4	Controls and Connections	14
B.5	Transducers and Mountings	16
B.6	Display and Data Storage	17
B.7	Direct Output	18
B.8	Power Supply	18
C	OPERATION	20
C.1	Initial Set-Up	20
C.1.1	Installation of mounting rails	21
C.1.2	Programming the application parameters	24
C.1.3	Installation of the transducers	26
C.1.4	Zero set / zero point calibration	28
C.2	Start Up Menu	30
C.2.1	Enter start up menu	30
C.2.2	Application Functions	30
C.2.3	Plausibility check	34
C.3	Error Detection	35
C.3.1	Low signal marker function	35
C.3.2	Error messages	36
C.4	Data Collection	38
C.4.1	Data collection procedure	38
C.4.2	Transfer to PC (data and parameters)	40
C.4.3	Parameter handling	41
C.5	Quit / Reset Menu	42
C.6	Direct Output Ports	44
C.6.1	General	44
C.6.2	Output hold	44
C.6.3	Current output	44
C.6.4	Frequency output	44
C.6.5	Connection diagrams	45a
C.7	Trouble Shooting	46

D	PROGRAMMING MODE.....	48
D.1	General	48
D.2	How to Program.....	49
D.3	List of Functions	52
D.4	Main Menu: 3.0.0 INSTALLATION	54
D.5	Main Menu: 2.0.0 TEST	72
D.6	Parameter errors	74
E	MAINTENANCE.....	76
E.1	Fuse	76
F	TECHNICAL DATA.....	78
F.1	General	78
F.2	Transducers & Clamp-on Set	79
F.3	Signal Converter.....	80
	APPENDIX 1 : Pipe Material Sonic Velocities	84
	APPENDIX 2 : Sonic Velocities of Liquids	85
	APPENDIX 3 : Sonic Velocity Calculation.....	86
	APPENDIX 4 : Exponential Notation.....	87
	APPENDIX 5 : Default Settings + Example of Output Parameters	88
	APPENDIX 6 : Spare Parts	90



ALTOSONIC List of illustrations

UFM 600 T

Fig. B.1 :	Measuring principle.....	8
Fig. B.2 :	System diagram.....	11
Fig. B.3 :	UFM 600 T with all equipment displayed.....	13
Fig. B.4 :	UFC 600 T converter	15
Fig. B.5 :	Transducers and unit	16
Fig. C.1 :	Mounting rail	22
Fig. C.2 :	Mounting rails fitted on the pipe	22
Fig. C.3 :	Mounting positions.....	23
Fig. C.4 :	Position of transducer and cable.....	26
Fig. C.5 :	Upstream and downstream connections.....	27
Fig. D.1 :	Entering the programming mode.....	49
Fig. D.2 :	Low flow cutoff	55
Fig. D.3 :	Bi-directional flow (I)	61
Fig. D.4 :	Flow direction indication (I)	61
Fig. D.5 :	Positive flow (I)	61
Fig. D.6 :	Negative flow and output (I).....	61
Fig. D.7 :	Bi-directional flow (F).....	63
Fig. D.8 :	Flow direction indication (F)	63
Fig. D.9 :	Positive flow (F)	64

(I) current output
(F) frequency output



System Description

The Altosonic UFM 600 T is an ultrasonic flowmeter which can easily be clamped on existing pipelines with inner diameters between 50 mm and 3000 mm (2" to 120") and pipe wall thicknesses up to 40 mm.

Measurement is performed obstructionless, without changing the existing pipework and without any headloss.

The UFM 600 T is an economical solution for all kinds of flow measurements of liquids containing no or little solid particles or gas.

Examples are: cooling water, waste water, oil, acids, bases etc.

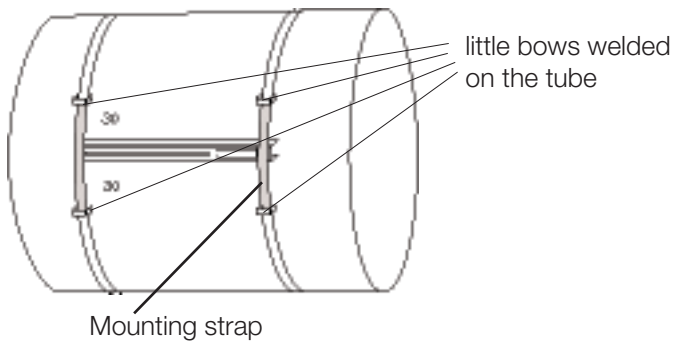

At mounting on diameters $> \text{DN } 1600$, we recommend to weld 4 little bows on the tube as indicated in the sketch.

See also Chap. C.1.1.



B.1 Measuring Principle

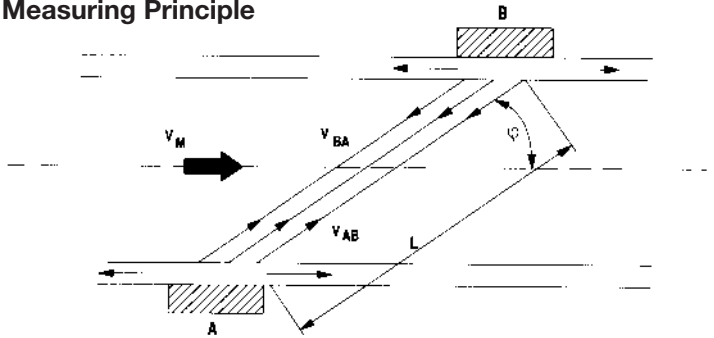

Fig. B.1 : Measuring principle

A sound wave that is sent in the direction of the flow through a medium will travel faster than one that is sent in the opposite direction.

This principle is used in the ultrasonic transit time flowmeter. Two ultrasound transmitters/receivers are fitted on opposite sides of the pipe section as shown in Fig. B.1.

Initially transducer A transmits an ultrasonic sound signal that will be received by transducer B. The time lapse t_{AB} between transmission and reception is measured.

Then the functions of both probes are reversed and the transit time t_{BA} in the opposite direction is measured.

From t_{AB} and t_{BA} the actual flow can be calculated taking into account the following factors:

- pipe diameter
- wall thickness
- lining thickness, if applicable
- sonic velocity in the liquid
- sonic velocity in the pipe material
- sonic velocity in the pipe lining material, if applicable

Measurements are taken continuously.

NOTE: Each transducer transmits and receives ultrasound signals.



B.2 Measuring System

A microprocessor controls the transducers via an analog/digital interface and calculates the actual flow. The control program is stored in EPROM memory.

Parameters for the application and processing the data are entered via the keyboard.

A liquid crystal display is used for the indication of all measuring data.

All data collected in the field can be stored in RAM memory and transferred to an IBM compatible PC via an RS 232 output; the same applies to the parameter settings.

Both current and frequency output signals are available for auxiliary readout and/or control purposes.

Figure B.2 shows a diagram of the flowsystem.

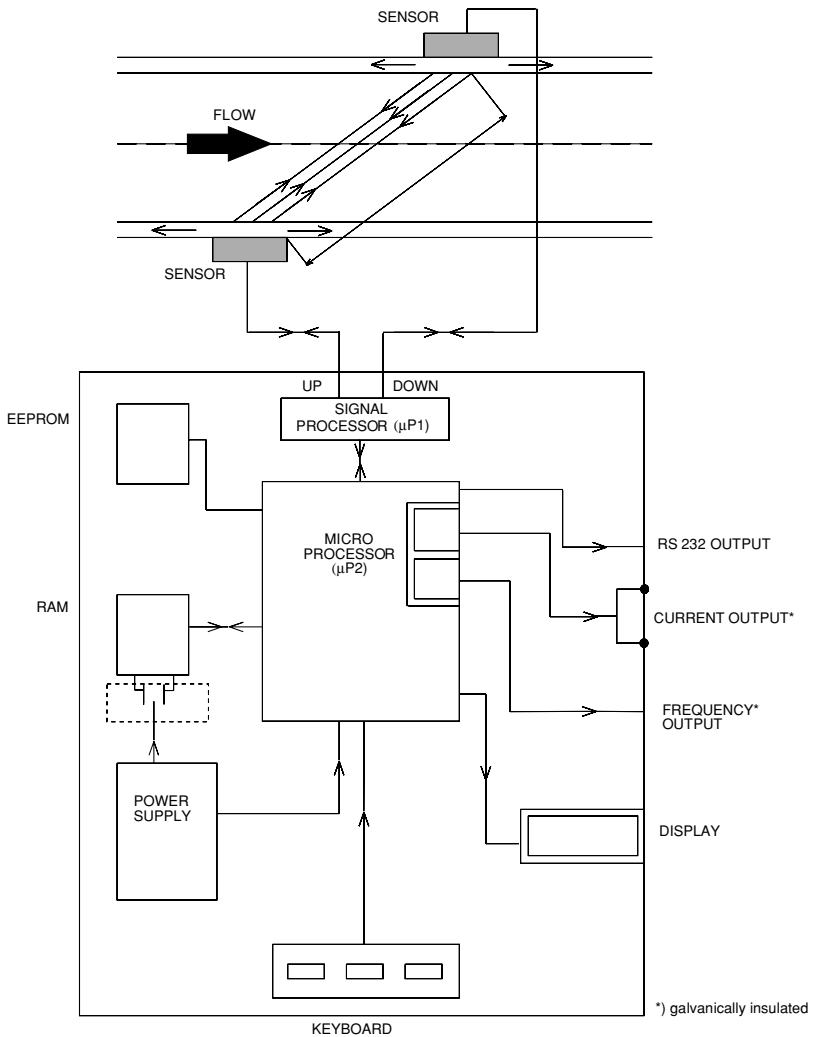

Fig. B.2 : System diagram

B.3 Equipment

The UFM 600 T flowmeter is fitted in a sturdy case.

Figure B.3 shows the UFM 600 T with all items displayed:

1. UFC 600 T signal converter (1x)
2. RS 600 clamp on transducer (2x)
3. Shielded cable (coax) (2x)
4. Grounding cable (1x)
5. Small mounting strap (2x)
6. Large mounting strap (4x)
7. Mounting rail (2x)
8. Acoustic coupling grease (1x)
9. Measuring tape (5m) (1x)
 - Manual and data sheets
 - 3,5" diskette
10. Magnet bar (1x)

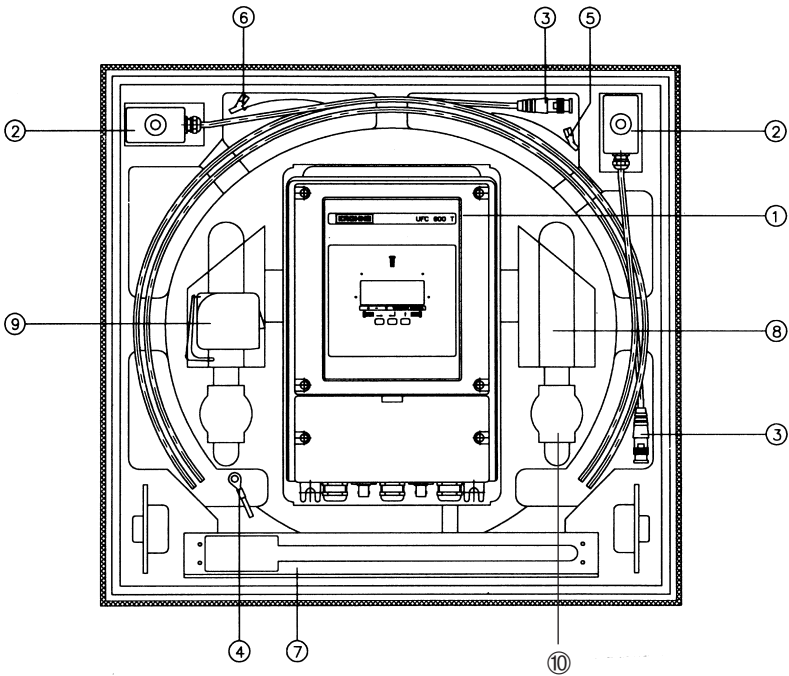

Fig. B.3 : UFM 600 T with all equipment displayed

B.4 Controls and Connections

Figure B.4 shows the controls and connections of the flowmeter unit.

- 1 Liquid crystal display
- 2 Keyboard (3 keys)
- 3 Power supply (term. 11,12)
- 4 Connector for upstream transducer
- 5 Connector for downstream transducer
- 6 RS 232 output for PC
- 7 mA-Output (term. 5, 6)
- 8 Frequency output (term. 4,.4.1, 4.2)
- 9 Hall contacts

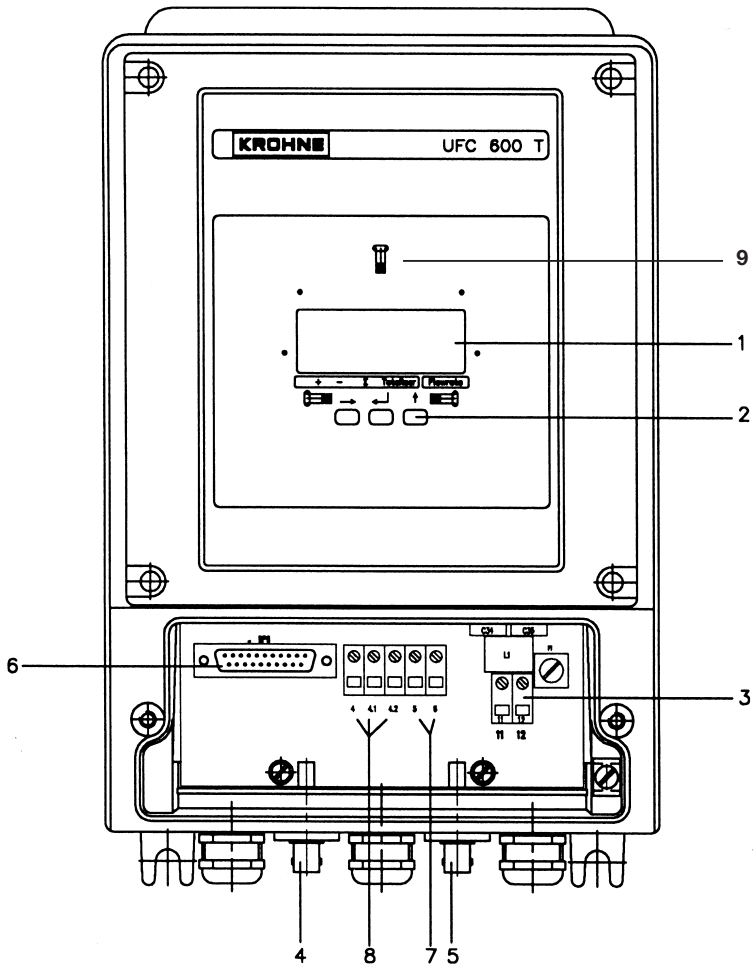

Fig. B.4 : UFC 600 T converter

B.5 Transducers and Mountings (see Fig. B.5)

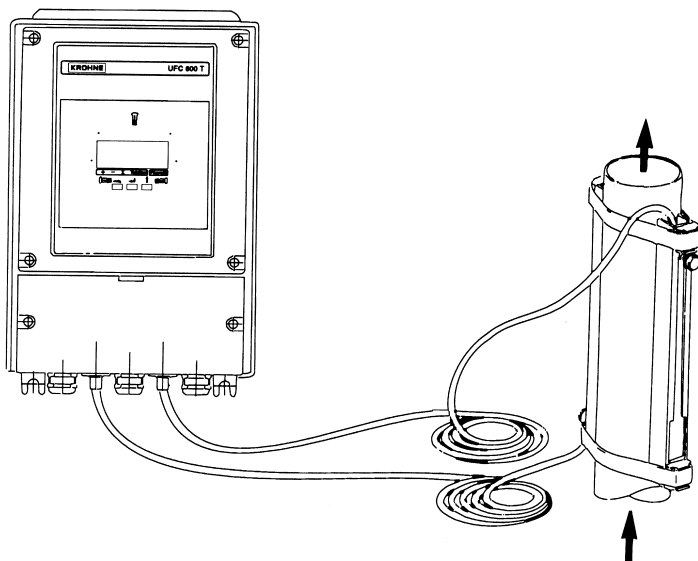

Fig. B.5 : Transducers, signal converter and auxillary items

Two mounting rails are clamped against the pipe wall by two straps.

The transducers can slide inside the mounting rails to obtain the correct distance between them. The transducers are then tightened firmly against the pipe wall.

Coupling grease is used between the transducers and the pipe wall to provide a good transfer of the ultrasound signal through the pipe material.

The transducers are connected to the control unit by means of two shielded cables.

B.6

Display and Data Storage

Display:

The following display options are available:

- Actual flow rate and direction.
- Total positive and negative flow volume since the start of the measuring session.
- Absolute flow volume since the start of the measuring session.
- Transit time of the acoustic signal.
- Error messages.
- Back lit function of the display.

Since the display shows only one read out at a time, they can be viewed sequentially.

Collect data:

At a programmable interval, all flow information selected to be displayed can be stored and sent to a PC via the RS 232 output. Also the parameter settings can be send to a PC.



B.7 Direct Output

Both current and frequency output signals are available for control purposes. These can be either analog signals or just flow direction indicator signals.

To avoid adverse effects on equipment connected to the flowmeter a signal hold function can be activated; this is important if the flowmeter is being used as part of a control loop. When you terminate the measuring session the last output signal can be maintained.

B.8 Power Supply

The flowmeter can be delivered in two versions for different power sources:

- AC Power supply 85 - 264 VAC
- DC power supply 18 - 32 VDC

When the unit is switched off, the data stored in the volatile memory is maintained by a backup battery on the microprocessor board.

This battery is capable of supporting the RAM for at least 5 years.



C.1 Initial Set-Up

The main steps of the installation procedure of the flowmeter are:

- 1 Install the mounting rails on the pipe.
- 2 Program the application parameters through the Start Up Menu, up to the point where the microprocessor calculates the transducer distance.
- 3 Install the transducers in the mounting rails, according to the microprocessor calculated distance.
- 4 If applicable perform a zero point calibration.

C.1.1 Installation of mounting rails

Mounting Considerations:

The pipe section on which the transducers will be clamped must always be completely filled with liquid, even if there is no flow.

The transducers can be fitted on both horizontal and vertical pipe sections (or any other elevation).

On horizontal pipes the transducers should be fitted such that the ultrasonic pulse travels approximately horizontally through the pipe since gas/vapour at the top of the pipe or any contamination at the bottom can cause an obstruction to the ultrasonic pulses.

The solid or gas content of the liquid must not exceed 1 per cent by volume.

Note that, due to cavitation, bubbles can appear behind valves, pumps etc., so the transducers should not be installed too closely to these positions.

The absolute minimum distances are given in the table below.

Highly distorted flow profiles may require significantly longer straight upstream lengths.



Upstream straight length	
- when mounted behind a pump	≥ 15 x DN
- when mounted behind a fully opened valve	≥ 10 x DN
- when mounted behind one or more elbows	≥ 10 x DN
- when mounted behind a reduction $\alpha/2,7^\circ$	≥ 5 x DN
Downstream straight length	≥ 5 x DN

(DN: Nominal Diameter)

Mounting Procedure:

- a Severe rust or thick coatings have to be removed from the pipe where the transducers will be installed.
- b Slide the securing straps through the slots on both ends of each mounting rail (see fig. C.1).

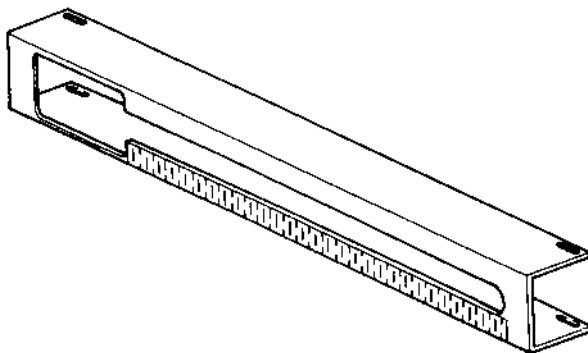

Fig. C.1 : Mounting rail

- c Attach the rails on opposite sides of the pipe such that the large slots point in opposite directions (see fig. C.2).

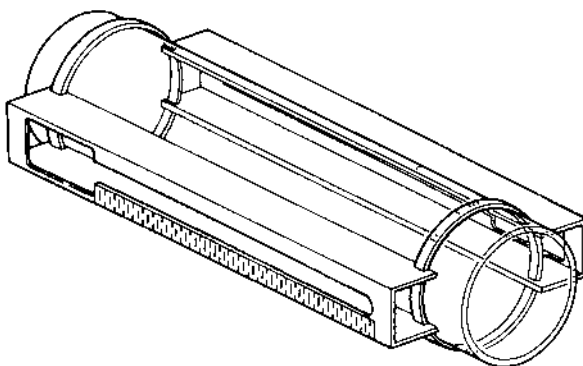
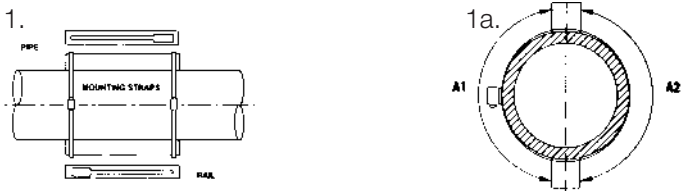
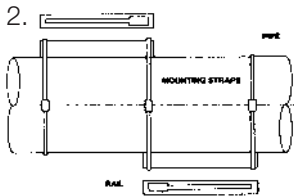

Fig. C.2 : Mounting rails fitted on the pipe

- d Use the supplied tape measure to ensure that the rails are fitted diametrically opposite each other (see fig. C.3-1a.).
Distance A1 must equal distance A2. Secure the rails by tightening the straps.



Mounting position if calculated transducer distance does not exceed 350 mm (14")



Mounting position if calculated transducer distance is between 350 mm (14") and 700 mm (28")

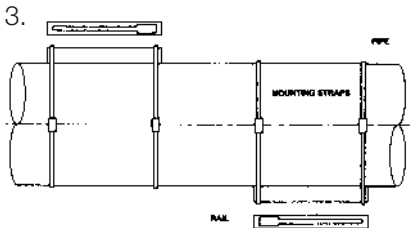

Mounting position if calculated transducer distance does exceed ≥ 700 mm (28")

Fig. C.3 : Mounting positions



C.1.2 Programming the application parameters

After the flowmeter has been switched on it will start in the measuring mode.

Pressing twice the  key enters the Start Up Menu.

In this menu the application related parameters can be programmed.

All functions are described in section C.2.

Push Button Functions

The flowmeter can be programmed by means of the three keys located below the liquid crystal display.



By pushing the left-hand key 'ARROW RIGHT' the parameter shown on the display will be activated and the desired value can be entered or an option can be selected.



After pushing the key in the middle 'ENTER' the programmed information will be stored and the program advances to the next parameter.



For entering numbers or letters the 'ARROW UP' key must be used; this will increment the ASCII value of the blinking character (next higher number or next letter in the alphabet).

If a selection from a table must be made the 'ARROW UP' key can be used to display the next option in the table. After using the 'ARROW UP' key without actually programming a parameter the next parameter will be displayed.

Input of values

Input of values outside the range, indicated at the function descriptions, will result in a flashing error message; the minimum or maximum value allowed is displayed above the error message.

After pressing any key the function is active again and the correct value can be entered.

Start Up Menu

Enter all application parameters in the Start Up Menu; see section C.2 for full details. Continue until the transducer distance is on display. Now the transducers can be installed.



C.1.3 Installation of the transducers

Since the required transducer distance "S" is known now the transducers can be positioned in the rails:

- 1 Turn the transducer securing screw completely counter clockwise until the transducer positioning plate touches the top of the transducer housing.
- 2 Feed the coax cables through both mounting rails.
- 3 Cover the bottom of both transducers with a thick layer of the sonic coupling grease.
- 4 Connect each transducer to a coax cable and slide the transducers into the rails (fig. C.4.) While inserting the transducers, care must be taken not to touch the pipe wall with the transducers before the proper position is obtained, otherwise the coupling grease will be wiped off the transducers and the result will be a bad sonic coupling between the transducers and the pipe wall.

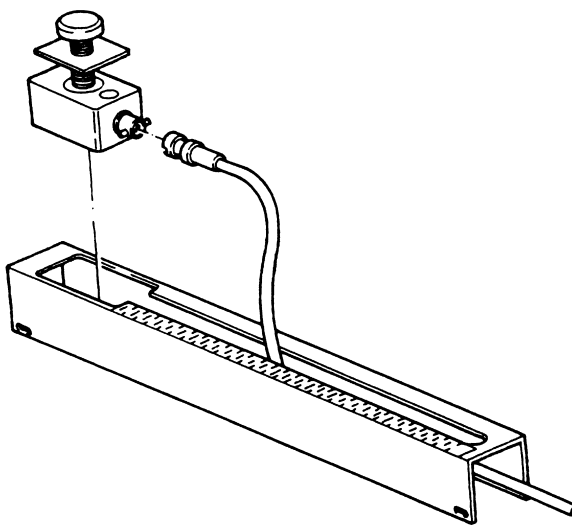

Fig. C.4 : Position of transducer and cable

NOTE:

- The cable connections at the transducers must always point away from each other (fig. C.5).
- Make sure that the transducers are not placed over a welding seam.

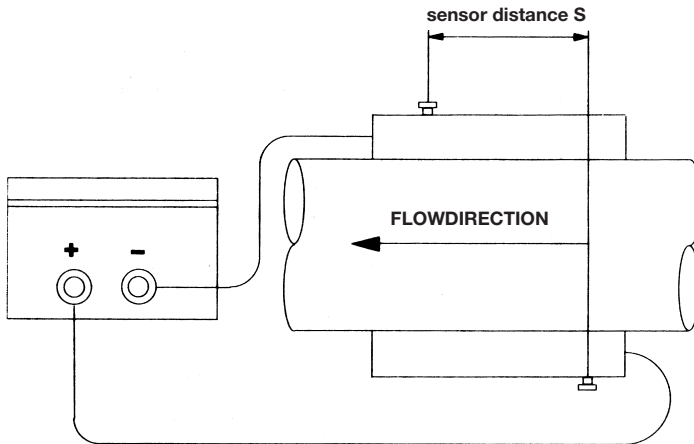

Fig. C.5 : Upstream and downstream connection

- 5 Use the cm scale on the mounting rails to position the transducers at the proper distance from each other and hand tighten the securing screws.
- 6 Check using the indication of the low signal marker (see C 3.1) whether the unit is functioning properly.

Continue with Zero Set function (C.1.4.)

NOTE: REMOVAL OF THE TRANSDUCERS FROM PIPE WALL

When removing the transducers from the pipe wall, especially after they have been in place for a long period, care should be taken:

- Not to damage the transducers by pulling strongly at the securing screw.
- Therefore, to remove a transducer, it must be removed in a slicing motion. Do not just pull it straight off the pipe !!

C.1.4 Zero set / Zero point calibration

Zero Set

After leaving the transducer distance function the ZERO SET function can be activated.

The flowmeter is functioning now without displaying any flow readings. Only the low signal marker (see C.3.1) gives an indication of the signal quality based on the factory set default zero point calibration.

The low signal marker will indicate if a zero point calibration is feasible.

A zero point calibration is strongly advised as this will improve the overall accuracy.

If no zero point calibration is to be executed, this function can be skipped.







See also section C.3, Error Detection, for the accuracy to be expected.

Zero Point Calibration

Before performing the zero point calibration ensure that:

- The unit is functioning properly (see low signal marker).
- There is no flow at the location where the transducers are installed and the pipe section is completely filled with liquid.

Now activate the Start Up Menu and enter the ZERO SET function:

- With  DEFAULT or MEASURED will be visible
- Use  to select between DEFAULT or MEASURED
- If DEFAULT is selected press  to set the preprogrammed DEFAULT zero point
- If MEASURED is selected press 
- Now CALIB. NO will be visible.
- Use  to select YES and press 
- The microprocessor now performs an input signal test.
- On the top line the zero point correction in % is displayed.
- If the correction is near 0% the calibration was successful; select STORE YES and press  to save the zero point calibration.

If no reliable signal is detected the error message BAD ZERO is displayed and the calibration should be abandoned; in order to restart the zero point calibration procedure. The data collection can be started now or other parameters can be entered through the programming mode (chapter D).

NOTE:

MEASURED zero point is selected if there is no flow. DEFAULT zero point should be selected if the flow cannot be stopped.



C.2 Start Up Menu

C.2.1 Enter start up menu

The Start Up Menu is activated by pressing the \rightarrow key twice from the measuring mode or pressing the \rightarrow key once from the main menu 1.0.0.

C.2.2 Application Functions

The functions in which the application parameters can be programmed always appear on the display in the same order as described below:

To enter a next function, the \uparrow key must be pressed.

DIAMETER

Program the outer pipe diameter.

The diameter can be entered either in mm or in inches.

Range:

$2.0000 \text{ E } 0 \text{ mm} \leq \text{DIAMETER} \leq 4.0000 \text{ E } 3 \text{ mm}$

$7.8740 \text{ E-}2 \text{ inch} \leq \text{DIAMETER} \leq 1.5748 \text{ E } 2 \text{ inch}$

PIPEWALL

Program the pipe wall thickness.

The wall thickness can be entered either in mm or in inches.

Range:

$1.0000 \text{ E-}1 \text{ mm} \leq \text{PIPEWALL} \leq 5.0000 \text{ E } 1 \text{ mm}$

$3.9370 \text{ E-}3 \text{ inch} \leq \text{PIPEWALL} \leq 1.9685 \text{ E } 0 \text{ inch}$

PIPE MAT.

Program the sonic velocity of the pipe material.
The following 5 options are preprogrammed (or will reappear after running 3.5.8 DEFAULT SET, see chapter D):

STEEL	:	3.1700 E 3 m/s
ST. STEEL	:	3.1200 E 3 m/s
IRON	:	2.1200 E 3 m/s
PVC	:	2.1200 E 3 m/s
Other	:	1.5000 E 3 m/s

All five option positions can be reprogrammed completely according to the user's requirements (**names and sonic velocities**).

The sonic velocity can only be programmed in m/s.

Range:

$1.5000 \text{ E } 3 \text{ m/s} \leq \text{Sonic velocity} \leq 4.7500 \text{ E } 3 \text{ m/s}$

See appendix 1 for sonic velocities of the most frequently used pipe materials.

LINING

Select YES or NO depending on whether or not the pipe is provided with a lining.

When NO is selected the parameters LINING THICKNESS and LINING MATERIAL can not be programmed.

LINING TH.

(does not appear on display when lining = "NO")

The lining thickness can be entered either in mm or in inches.

Range:

$1.0000 \text{ E-1 mm} \leq \text{LINING THICKNESS} \leq 5.0000 \text{ E } 1 \text{ mm}$

$3.9370 \text{ E-3 inch} \leq \text{LINING THICKNESS} \leq 1.9685 \text{ E } 0 \text{ inch}$



LINING MAT.

(does not appear on display when lining = "NO")

Program the sonic velocity of the lining material.
The following 5 options are preprogrammed (or will reappear after running 3.5.8 DEFAULT SET, see chapter D):

PVC	:	2.1200 E 3 m/s
Other 1	:	1.0000 E 3 m/s
Other 2	:	1.0000 E 3 m/s
Other 3	:	1.0000 E 3 m/s
Other 4	:	1.0000 E 3 m/s

The sonic velocity can only be programmed in m/s.

Range:

$3.0000 \text{ E } 2 \text{ m/s} \leq \text{Sonic velocity} \leq 4.7500 \text{ E } 3 \text{ m/s}$

See appendix 1 for sonic velocities of some lining materials used frequently.

All five option positions can be reprogrammed completely according to the user's requirements (**names and sonic velocities**).

LIQUID

Program the sonic velocity of the liquid inside the pipe.

The following 5 options are preprogrammed (or will reappear after running 3.5.8 DEFAULT SET, see chapter D):

WATER	:	1.5000 E 3 m/s
Other 1	:	1.0000 E 3 m/s
Other 2	:	1.0000 E 3 m/s
Other 3	:	1.0000 E 3 m/s
Other 4	:	1.0000 E 3 m/s

The sonic velocity can only be programmed in m/s.

Range:

$1.0000 \text{ E } 2 \text{ m/s} \leq \text{Sonic velocity} \leq 2.5000 \text{ E } 3 \text{ m/s}$

See appendix 2 for sonic velocities of frequently encountered liquids.

All five option positions can be reprogrammed completely

according to the user's requirements (**names and sonic velocities**).

NOTE: If the sonic velocity is not known it can be estimated by using the sonic velocity calculation, see appendix 3.

FULL SCALE

Select the flow rate units and program the full scale value. A selection can be made out of 9 preprogrammed units and one unit can be specified by the user (see function 3.5.3, 3.5.4 and 3.5.5 in chapter D).

Unit	Range	
m ³ /Sec	9.4240 E-7	≤ F.S. ≤ 1.5080 E 2
m ³ /min	5.6533 E-7	≤ F.S. ≤ 9.0481 E 3
m ³ /hr	3.3926 E-3	≤ F.S. ≤ 5.4288 E 5
Liter/Sec	9.4240 E-4	≤ F.S. ≤ 1.5080 E 5
Liter/min	5.6544 E-2	≤ F.S. ≤ 9.0481 E 6
Liter/hr	3.3926 E 0	≤ F.S. ≤ 5.4288 E 8
US G/Sec	2.4896 E-4	≤ F.S. ≤ 3.9837 E 4
US G/min	1.4937 E-2	≤ F.S. ≤ 2.3902 E 6
US G/hr	8.9624 E-1	≤ F.S. ≤ 1.4341 E 8
...../.....	9.4240 E-7	≤ F.S. ≤ 1.5080 E 2 (user defined unit)



LOCATION

The name of a measuring site or tag number can be programmed here. When function 3.6.5 is activated (see chapter D) the location name will be recorded in the header of each data block that is stored.

SENS. DIST.

After the previous parameters in the Start Up Menu have been programmed, the microprocessor will calculate, either in mm or inches as chosen for under diameter, the desired distance between the two transducers, measured along the pipe axis. Enter this function to read the result on the display.

ZERO SET :

Zero point calibration.

Select between the factory set default value for the zero point or perform a zero point calibration for the actual situation.

See paragraph C.1.4 for the precise conditions and instructions for a calibration.

C.2.3 Plausibility check

After any changes are made to the parameter settings the microprocessor will perform a plausibility check on the changed settings, before the measuring mode can be activated. If no "impossibilities" in the configuration are detected the microprocessor asks for confirmation before the new settings are stored.

If discrepancies in the parameters entered are found the microprocessor will display the message "PARAMERROR" which prevents you from storing parameters that are incorrect; the options available to correct the configuration are described in section D.6.

The next function which will appear is again, the first function of this Start Up Menu: "DIAMETER".

The Start Up Menu is left by pressing the  key once from any function name in the Start Up Menu. When doing this, the Main Menu will be entered (function 1.0.0.)

C.3 Error Detection

C.3.1 Low signal marker function

The condition of the input signal from the transducers is indicated by a marker in the top left hand corner of the display. The marker consists of four arrows divided over 360 degrees.

The microprocessor calculates the percentage of the measurements that is inconsistent.

Marker indications:



> 80 % of measurements inconsistent

The flowmeter will not function.



40 % of measurements inconsistent



20 % of measurements inconsistent

The flowmeter will function, though not optimally.



10 % of measurements inconsistent



No inconsistent readings detected

Optimal functioning flowmeter.



C.3.2 Error messages

If the microprocessor produces an error message a * sign appears at the lower left hand side of the display.

Enter the QUIT / RESET mode to view the error message(s) (see chapter C.5).

It depends on the settings of the Installation functions 3.2.4 and 3.2.6, whether the error messages will be displayed in between the flow data.

List of Error Messages:

SIGN LOST	:	Transducer disconnected
TOTALIZER	:	Overflow of the totalizer.
FREQ.OUTP. F:		Overflow of the frequency signal; full scale value is too small
CUR. OUTP. I :		Overflow of the current signal; full scale value is too small
CAL. DATA	:	The transducer calibration is distorted; contact your supplier
EE1 EE2	:	Error detected during memory check; switch unit off and on; if message still reappears after two attempts, contact your supplier
EEPROM2	:	See EE1 EE2
ROM	:	Checksum error detected during memory test; contact your supplier
RAM	:	Error detected during verification of parameter settings stored previously; use function 3.5.8 DEFAULT SET and switch off and on; if message reappears contact your supplier.

STORE:	A total number of 350 data blocks are been stored. Rest capacity 40 data blocks till data storage is full.
FATAL ERROR:	Check sum error detected; contact your supplier.
PARAMERROR:	This message will not appear during measurement; at the end of both the start up menu and the programming mode a parameter check is performed before the measuring mode can be entered (see section D.6).



C.4 Data Collection

C.4.1 Data collection procedure

Sampling Rate / Data Storage Capacity

A total number of 390 data blocks can be stored.

This number is independent of the amount of information that is programmed to be on display and/or stored.

It is very important to determine a useful combination of the measuring period and the data sampling rate.

If the flow rate shows only minor fluctuations or fluctuations are not relevant a low sampling rate can be programmed. Thus a long measuring period can be achieved or more than one data collecting interval can be realized before the data has to be transferred to a PC.

If the flow rate fluctuations are important the sampling rate should not be too low. Otherwise, relevant information might not be recorded.

NOTE:

When all 390 data blocks are occupied no further data will be stored. The flowmeter will continue to operate normally.

WARNING IS GIVEN WHEN THE DATA STORAGE IS FILLED WITH 350 DATA BLOCKS (See chapter C.3.2. Error Messages)

Reset Data

If a new measurement series is started (previous flow data can be discarded) the data blocks can be cleared; two RESET DATA functions are available:

- 1 use the function 3.6.6, RESET DATA, in the programming mode
- 2 enter the QUIT/RESET menu (see section C.5.) from the measuring mode and select the RESET DATA option.

Reset Totalizers

If applicable the totalizers must be reset at the beginning of a measuring series. Enter the QUIT/RESET menu from the measuring mode and select the totalizer(s) that have to be reset (see section C.5)

Preparation for new measurements

Providing any previous flow data can be discarded, a data collection session can be started as follows:

- 1 Select the STORE or BOTH option of function 3.6.3 in the programming mode
- 2 Clear the RAM by means of one of the two ways to Reset Data
- 3 Start the measuring mode
- 4 If applicable reset the totalizers

Preparations for continued measurements

It is advisable not to activate the STORE option of function 3.6.3 in the programming mode until the actual measuring period is to be started; otherwise unnecessary data blocks are being stored and storage space is lost.

After installing the transducers it is advisable to run in the measuring mode for some time during which the data is only sent to the display (function 3.6.3 OFF).

The readings can be checked and adjustments made (e.g. adjust full scale value) to ensure that the suitable data is collected.

The actual measuring period with data storage (and the RAM partially filled) can then be started as follows:

- 1 Select the STORE or BOTH option of function 3.6.3 in the programming mode
- 2 Leave the programming mode and enter the measuring mode via the DIAMETER prompt of the Start Up menu
- 3 If applicable, reset the totalizers



C.4.2 Transfer to PC (data and parameters)

Software

The floppy disk provided contains programs for the transfer and conversion of the measuring data:

- GETFLOW.EXE

Function : Transfer measuring data and/or parameter settings to the PC
The information will be stored in ASCII format.

Syntax : GETFLOW <com> <file>
<com> : the number of the serial port on the PC.
<file> : file name for the data to be stored.

- FLOW2CEL.EXE

Function : Convert the ASCII data for processing by Harvard Graphics, VP Planner or Lotus 1,2,3.

Syntax : FLOW2CEL <input file> <output file>
<Language>
WITH Language:
E = English
D = Deutsch
F = Francais
N = Nederlands

NOTE: Both programs show their syntax if they are run without or with false extensions.

- README_E.DOC

If applicable this file offers an update on the software information.

Data transfer

For the transfer of information from the flowmeter to the PC proceed as follows:

- Connect the RS 232 cable to the flowmeter and the serial in/output port of the PC (com1 or com2).
- Enter the programming mode of the flowmeter and activate the function 3.6.1 or 3.6.2 for either the output of the parameter settings or the measuring data; see that the selection is on YES
- Run program GETFLOW on the PC
For example if the Com1 port is connected and the data has to be stored in file FLOW.DAT then type:
GETFLOW 1 FLOW.DAT
The message WAITING FOR DATA will appear.
- Now press  on the flowmeter within 3 seconds.
- The data is transmitted to the PC and stored in the file indicated using the ASCII format.



Data conversion

After all flow information is stored in an ASCII file use program FLOW2CEL to convert the data to a format that can be adapted for presentation purposes.

Run program FLOW2CEL on the PC and follow the instructions displayed.

See README _ E.DOC for any additional information.

C.4.3 Terminal programs

Standard terminal programs (e.g. MS Windows® terminal) can be used to receive data from the UFC 600 T signal converter by using a straight RS 232 cable with 25 pins female D-connector.

Settings must be:

BAUDRATE	2400
DATA BITS	7
STOP BITS	1
PARITY	NONE

C.5 Quit / Reset Menu



The measuring mode can be exited with the code as described below to enter the Quit/Reset Menu.

In this menu two functions can be used:



ERRORLIST :

Show the list of errors indicated by the * sign at the left-hand side of the display.

When the error messages are not programmed to appear on a regular display (function 3.2.4 and 3.6.4) the only way to recognize an error (apart from the low signal marker) is by the * sign at the left-hand side of the display.

Enter the error list with the  key; the number of errors and the first error message will be visible. Use the  key to display the other error(s); eventually the ERR.ACQUIT function will appear.

ERR.ACQUIT function:

After curing the cause of the error(s) enter the ERR.ACQUIT function by using the  key and select YES with  key to reset the error message and error marker *.

Even if the cause of an error is cured the error message and the error marker will not disappear until they are cleared by the ERR.ACQUIT function.

Use the  key to leave the function.

Use the  key to return to the measuring mode.

- * Note that these error messages differ from those included in the data block that is stored and sent to the RS 232 output at regular intervals (function 3.2.4 and 3.6.4) : at the end of the next complete data collection interval following the elimination of the errors these messages will have disappeared automatically.

RESET :

In this submenu three reset options are available:



TOTAL +	:	Reset + totalizer.
TOTAL -	:	Reset - totalizer.
RESET DATA	:	Reset all data blocks.

In each option YES or NO must be selected.

The reset option is to be used to obtain a clear start of a data sampling session.

Use the  key to return to the measuring mode.

CODE :

The code to exit the measuring mode and to enter the Quit/Reset mode is:   

Although the code is rather simple it prevents the collected data from being wiped out unintentionally.

If within 3 or 4 seconds the proper code has not been entered the measuring mode is resumed without having been interrupted.



C.6 Direct Output Ports (Analog (mA) output and frequency / pulse output)

C.6.1 General

The options available for these direct output ports are described further in section D.4 main menu: 3.0.0 INSTALLATION.

Refer to the technical specifications if any equipment is to be connected to the current and/or frequency output. (see C.6.3, C.6.4 and chapter F)

C.6.2 Output hold

It is advisable to activate the output hold function (3.5.2) when the flowmeter is being used as part of a control loop.

NOTE: This hold function also affects the outputs in case of malfunction (signal lost).

C.6.3 Current output

Specification:

Range : 0 to 20 mA, or 4 to 20 mA or I
0% to...;I 100% programmable

Load : $R_L [\text{kohms}] < \frac{14 [\text{V}]}{I 100\% [\text{mA}]}$

(e.g. 0.7 kohms at 20 mA,
2.8 kohms at 5 mA).

C.6.4 Frequency output

Specification:

Pulse rate for Q=100%: 10 to 36 000 000 pulses per hour
0.167 to 600 000 pulses per
minute
0.0028 to 10 000 pulses per
second (=Hz)
optionally in pulses per liter, m³ or
US gallons

Active output
 Terminals 4.1/4.2 : short-circuit-proof
 for electromechanical (EMC) or
 electronic (EC) totalizers
 Terminals 4/4.1/4.2: for electronic (EC) totalizers
 Amplitude : approx. 27 V
 Load rating : see Table "pulse width"

Passive output
 Terminals 4/4.1 : open collector for connection of
 active electronic totalizers (EC)
 or switchgear
 Input voltage : 5 to 30 V
 Load current : max. 100 mA

Pulse width is automatically chosen, depending on actual out frequency.



Frequency f at Q=100%	Pulse width	Load rating of active output	
		Load current	Load
$0.0028 \text{ Hz} < f \leq 1 \text{ Hz}$	500 ms	$\leq 150 \text{ mA}$	$\geq 180 \text{ Ohm}$
$1 \text{ Hz} < f \leq 10 \text{ Hz}$	approx. 50% duty cycle (1:1)	$\leq 25 \text{ mA}$	$\geq 1 \text{ k Ohm}$
$10 \text{ Hz} < f \leq 1000 \text{ Hz}$	50% duty cycle (1:1)	$\leq 25 \text{ mA}$	$\geq 1 \text{ k Ohm}$
$1000 \text{ Hz} < f \leq 2547 \text{ Hz}$	160 μs	$\leq 25 \text{ mA}$	$\geq 1 \text{ k Ohm}$
$2547 \text{ Hz} < f \leq 10000 \text{ Hz}$	50 μs	$\leq 25 \text{ mA}$	$\geq 1 \text{ k Ohm}$

C.6.5 Connection Diagrams

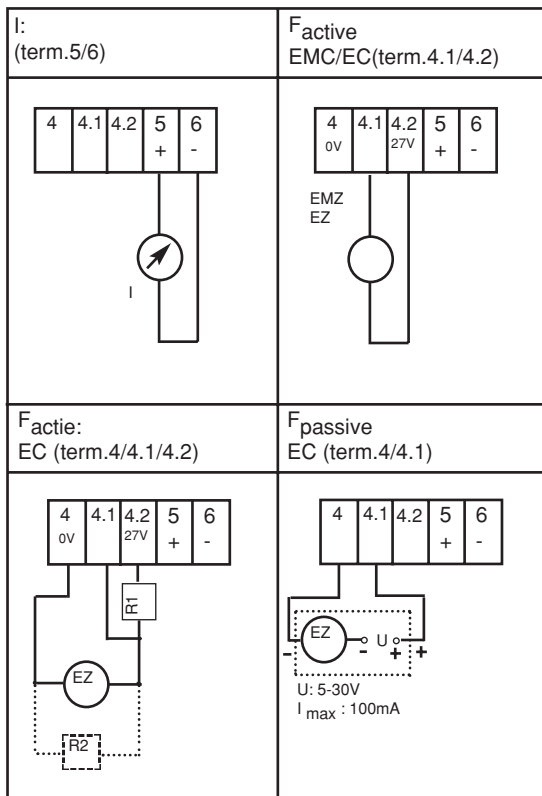





C.7 Trouble Shooting

1 **The flowmeter does not respond after connection to the main power supply** (no display or output messages).

- Check fuse.

2 **The error marker * appears on the display**

- Leave the measuring mode and enter the Quit/Reset menu (press    ; see section C.5). Cure the cause if necessary, and select ERR.ACQUIT to reset the error marker.

3 **Low signal marker: 3 or 4 markers on.**

Cause

Solution

Incorrect transducer

Reposition transducers (see section position C.1.3) using sufficient coupling grease and check the transducer distance afterwards.

Poor sonic coupling between pipewall and transducer surface

Check the pipe wall surface; remove any rust, dirt and/or thick layers of paint or coating. Apply sufficient grease on the transducers and make sure not to wipe off any grease from the transducers while they are being reinstalled.

Pipe is not completely filled

Fill the pipe completely or select a pipe section that is always completely filled with liquid.

Broken signal cable

Use a multimeter to check the condition of the cables and the connectors. See your supplier for

replacements. If 3 or 4 markers remain the selection of a different location on the pipe wall is recommended; some irregularities at the interior of the pipe might have caused poor signal reception.

5 Low signal marker: 1 or 2 markers on.

Cause

Small deviation of the transducer distance from the correct value

Solution

Adjust one transducer approx. ± 5 mm. until the markers disappear; do this very carefully so as not to disturb the sonic coupling grease layer between the transducer and the pipe wall.



D.1 General

In the main menu, two Sub Menus can be activated:

Sub Menu 2 "*TEST*" :

Four function tests can be executed:

- Display test
- Microprocessor test
- Current output test
- Frequency output test

Sub Menu 3 "*INSTALLATION*" :

Enter all parameters that determine the initial settings of the flowmeter and the way the data is processed.

All functions available in both of these menus are listed in section D.3 and described further in sections D.4 and D.5.

D.2

How to Program

Push button functions:



move the menu pointer one step to the right to activate the submenu displayed.





either move the menu pointer to the left to leave a submenu or store entered data and leave the submenu.



will increment the ASCII value of the blinking character by one; either the next higher number or the next letter in the alphabet. Pushing this button in the measuring mode, the display will be illuminated for one hour.

Entering the Start Up Menu:

The Start Up Menu is entered by pressing twice the  key from the measuring mode or from the main menu 1.0.0. by pressing the  key once. The Start Up Menu is left by pressing the  key (once to return to main menu 1.0.0, four to return to measuring mode)



Menu selection:

By entering the main menu, the submenu Start Up 1.0.0. will be on display; use the  key to select the submenus TEST 2.0.0. or INSTALL 3.0.0.

If the Start Up Menu is to be selected, press  key when 1.0.0. is displayed.

Function selection:

Use the  key to select a function from the chosen submenu.

Activate the selected function by pressing the  key.

Enter numbers, characters and select units:

If applicable within a function, numbers, characters or units can be selected at the position which shows a blinking sign by using the  key.

This position is selected by using the  key.

The set up of the function is completed by pressing  ; the data is stored and the menu pointer returns to the active submenu.

Leave Submenu:

Press  to return to the main menu.

Ending the programming session:

Ending a programming session can be done by pressing  3 times while one of the submenus (1.0.0, 2.0.0 or 3.0.0.) is active.

The programmed parameters will be saved directly without a request whether the changes should be set.

After saving the parameters the microprocessor will go directly to the measuring mode.

If any discrepancies are detected the error message PARAMERROR is displayed and a separate menu is activated in which the parameters concerned can be corrected (see section D.6).

NOTE: To save the programmed parameters in the Start Up menu (fct. 1.0.0) press  three times.

The signal converter is equipped with magnetic sensors (hall contacts). This allows setting of the signal converter by means of a hand-held bar magnet. Function of sensors without removing the front cover is the same as the corresponding keys.

Hold the bar magnet by the black rubber cap. Apply blue end of the magnet (north pole) to the glass pane above the magnetic sensors.



D.3	List of Functions	
2.00	TEST	
2.1.0	DISPLAY	
2.1.1	DISP.TEST	
2.2.0	PROCESSOR	
2.2.1	8048 TEST	
2.3.0	CURR. OUTP.	
2.3.1	TEST I	
2.4.0	FREQ. OUTP.	
2.4.1	TEST F	
3.0.0	INSTALLATION	
3.1.0	FLOW DATA (Submenu)	Set flow parameters.
3.1.1	PRIM. CORR.(Function)	
3.1.2	TRAN. RANGE	
3.1.3	LF. CUTOFF	
3.1.4	CUTOFF ON	
3.1.5	CUTOFF OFF	
3.2.0	DISPLAY	Set output functions, L.C.Display and define the contents of the data blocks.
3.2.1	DISP.FLOW	
3.2.2	DISP.TOTAL	
3.2.3	UNIT TOTAL	
3.2.4	ERROR MSG.	
3.2.5	DISP TRAN. T.	
3.2.6	CYCL. DISP.	
3.3.0	CURR. OUTP.	Set up analog output.
3.3.1	FUNCTION I	
3.3.2	I 0 PCT.	
3.3.3	I 100 PCT.	
3.3.4	I MAX.	
3.3.5	T- CONST I	

3.4.0	FREQ. OUTP.	Set up frequency/pulse output.
3.4.1	FUNCTION F	
3.4.2	PULSOUTP.	
3.4.3	PULSRATE PULS/UNIT	
3.4.4	T- CONST. F	
3.5.0	SPEC. FCT.	Set special functions.
3.5.1	LANGUAGE	
3.5.2	OUTP. HOLD	
3.5.3	UNIT TEXT	
3.5.4	FACT. QUANT.	
3.5.5	FACT. TIME	
3.5.6	SET DATE	
3.5.7	SET TIME	
3.5.8	DEF.SET	
3.5.9	SOFTW.V - NR.	
3.6.0	COMM.DATA	Set Store/RS 232 output.
3.6.1	OUTP. PARAM	
3.6.2	OUTP. DATA	
3.6.3	SEL. COMM.	
3.6.4	INTERVAL	
3.6.5	LOCAT.	
3.6.6	RESET DATA	



NOTE: The function names used in the description of the functions are presented in the same way as on the L.C. display.

D.4 Sub Menu: 3.0.0 INSTALLATION

3.1.0 FLOW DATA : **set flow parameters**

3.1.1 PRIM. CORR. : Primary Correction

This function allows the user to correct the primary constant that is calculated by the microprocessor. Corrections on the primary constant are useful in the case of for example poor installation conditions or comparison to a reference flowmeter.

The primary constant will be multiplied by the number displayed; 1.0000 E0 means no correction and 1.1000 E0 indicates a correction of + 10%.

Range: $0.0000 E0 \leq \text{Prim. Corr.} \leq 2.0000 E0$

3.1.2 TRAN. RANGE : Transit (time) Range

Use this function only if the transit time of the acoustic signal (the time elapsed between transmission and reception) is used as output on either the current or the frequency output (see Fct. 3.3.1 and 3.4.1).

The transit time value that corresponds to 100% output is programmed.

Range: $2.0000 E1 \leq \text{Tran. Range} \leq 1.0000 E5 \mu\text{sec}$

Current output example:

If 200 μsec is entered and the 0 - 20 mA output is being used then an actual transit time of 150 μsec provides a 15 mA output signal. Likewise, if a 4 - 20 mA output is being used, a 16 mA signal would be the analog output.

Frequency output example:

If 200 μsec is entered and the pulse rate at full flow is programmed to be 10000 Hz then an actual transit time of 120 μsec is indicated by a 6000 Hz signal.

3.1.3 L.F. CUTOFF : Low Flow Cutoff

To avoid erroneous measurements at low flow rates the Low Flow Cutoff can be used (see Fig. D.2).

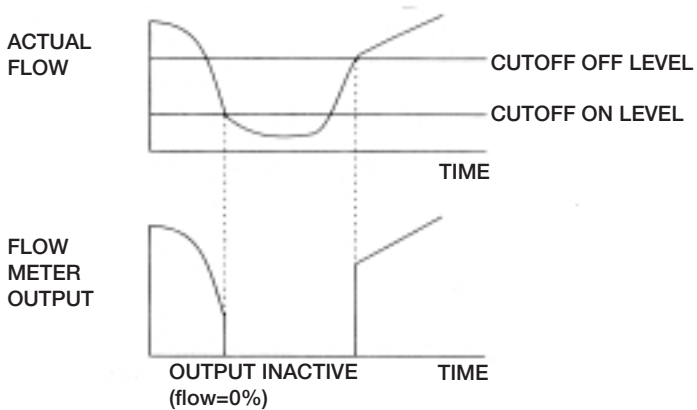

Fig. D.2 : Low flow cutoff



If the flow rate drops below the "Cutoff On" level all outputs will be switched off and if the flow rate exceeds the "Cutoff Off" level the outputs will be activated again.

The "Cutoff On" level must be lower than the "Cutoff Off" level otherwise a PARAMERROR message appears at the parameter check (see section D.6).

After entering the function either YES or NO can be selected. If YES is selected functions 3.1.4 and 3.1.5 become active.

If NO is chosen the low flow cutoff becomes inactive and functions 3.1.4 and 3.1.5 will not appear on the display.

3.1.4 *CUTOFF ON* : (only if at 3.1.3 YES was entered)

Program the flow rate level below which all outputs will be switched off.

Enter the value in % of the full scale.

Range: 1- 20

NOTE: This value must be lower than the Cutoff Off value !!

3.1.5 *CUTOFF OFF* : (only if at 3.1.3 YES was entered)

Program the flow rate level at which all outputs become active again.



Enter value in % of full scale.

Range: 1- 20

3.2.0 *DISPLAY* : **set output functions**
L.C.display

NOTE: All functions that are programmed to be on display can also be saved as programmed in function 3.6.3 SEL.COMM.



3.2.1 *DISP. FLOW* : Display Flow rate

Determine whether the flow rate should be displayed and if so, in what sort of units; select a display option using the  key and press  to store:

NO DISPLAY	:	
m3/Sec	:	
m3/min	:	
m3/hr	:	
Liter/Sec	:	
Liter/min	:	
Liter/hr	:	
US G/Sec	:	U.S. Gallon per second
US G/min	:	
US G/hr	:	
—/—	:	reserved for user defined unit
PERCENT	:	percentage of full scale as entered in Start Up menu



3.2.2 *DISP. TOTAL* : Display Totalisator
outputs

Select which totalizer outputs should be displayed by using the  key and press  to store:

NO DISPLAY	:	(function 3.2.3 will not appear)
+ TOTAL	:	Totalizer for positive flow
- TOTAL	:	Totalizer for negative flow
+/- TOTAL	:	Totalizers for both positive and negative flow
SUM TOTAL	:	[+ TOTAL]- [- TOTAL]
ALL TOTAL	:	All three totalizer options are active

3.2.3 *UNIT TOTAL* : unit for totalizers
(only if a totalizer has been set in 3.2.2)

Select unit for the totalizers using the key and press to store:

m3	:	
Liter	:	
US G	:	
-----	:	User defined unit

3.2.4 *ERROR MSG.* : Display Error Messages

Determine whether error messages should be displayed and if so, what type of error messages; select a message option using the key and press to store:

NO MESSAGE	:	
US ERROR	:	Only display of errors related to the measurement itself
TOT. ERROR	:	Display of totalizer errors only
ALL ERROR	:	

3.2.5 *DISP. TRAN. T* : Display Transit Time

The transit time is the time lapse between transmission of the acoustic signal by one transducer and the reception of the signal by the opposite transducer.

Select display of the transit time; choose either YES or NO using the key and press to store.

3.2.6 *CYCL. DISPL.* : Cyclic Display

The cyclic display option can be used to automatically change the function of the display, if more than one variable is programmed to be displayed.

Only one variable can be shown on the display at a time.

With this option active the display sequences from one variable to the next every 5 seconds.

If the error messages are programmed to be displayed, these appear in between the successive variables, if applicable.

For the totalizers and the flow rate, the actual function of the display is indicated by an arrow symbol ▼ at the bottom of the display.

If NO is selected the successive display of the variables is obtained by using the  key.



3.3.0 *CURR. OUTP.I* : **set up analog current output**

3.3.1 *FUNCTION I* : Program the analog current output

Select an output option using the  key and press  to store:

2 DIR : Enables flow measurement in 2 directions(+ and -) without change of polarity in the output signal (Fig. D.3)

TRAN. TIME : Output signal is proportional to the measured transit time of the acoustic signal.

NOTE: this function requires:

- current setting at zero flow, Fct. 3.3.2
- current setting at full flow, Fct. 3.3.3
- transit time at full flow, Fct. 3.1.2

(see example in description of Fct. 3.1.2)

NO SIGNAL : Output signal indicates "signal loss".

OFF : No current output.

F/R IND. I : Output signal as flow direction indication, 0% at + flow direction and 100% at -flow direction (fig. D.4).

1 DIR : Flow measurement in 1 direction (+) only. (Fig. D.5)

I < I 0 PCT : Allows the output signal to drop below the programmed value for 0% flow at negative (-) flow direction. If 10 mA is programmed for 0% flow (Fct.3.3.2) and 20 mA for 100% (Fct. 3.3.3) then the output will

be 0 mA at - 100% flow (fig. D.6)

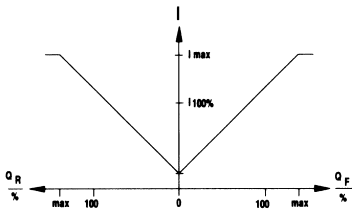

Fig. D.3 : Bi-directional flow (I)

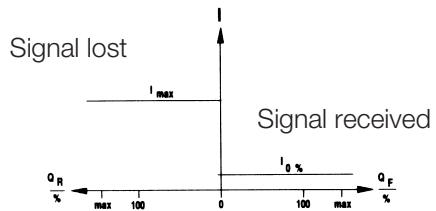

Fig. D.4 : Flow direction indication (I) or signal loss indication (I)

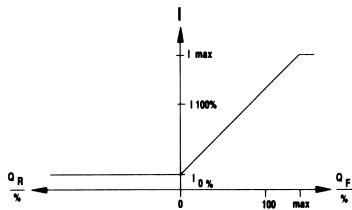

Fig.D.5 : Positive flow (I)

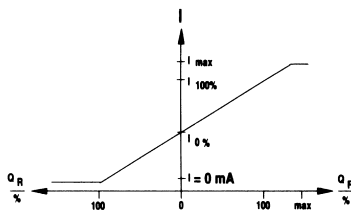

Fig. D.6 : Negative flow and output (I)

3.3.2 [I 0 PCT] : Program current output at 0 %flow

Range: $00 \text{ mA} \leq [I 0 \text{ PCT}] \leq 16 \text{ mA}$

NOTE: This value must be lower than the [I 100 PCT] value !!
If this is not the case, a PARAMERROR message will appear during the parameter check procedure.

3.3.3 [I 100 PCT] : Program current output at 100% flow.

Range: $04 \text{ mA} \leq [I 100 \text{ PCT}] \leq 20 \text{ mA}$

[I 100 PCT] must exceed [I 0 PCT] by at least 4 mA; if this is not the case, a PARAMERROR message appears during the parameter check (see section D.4).

3.3.4 [I MAX] : Program maximum output current

The maximum output level can be limited to protect accessory equipment.

Range: $04 \text{ mA} \leq I \text{ MAX} \leq 22 \text{ mA}$

[I MAX] must be equal to or greater than [I 100 PCT]; if this is not the case, a PARAMERROR message appears during the parameter check (see section D.4).

3.3.5 T - CONST.I : Time constant of current output

To flatten out sudden fluctuations in the current output signal a first order filter is included.

Program the time constant for the current output:

Range: $4.0000 \text{ E-2} \leq T - \text{CONST.} \leq 3.6000 \text{ E 3}$

Recommended initial value : 2 to 5 sec.

ATTENTION: Time constant also affects readings on LC-display.

3.4.0 FREQ. OUTP. F : **set up frequency / pulse output**

3.4.1 FUNCTION F : Program the analog frequency output

Select an output option using the \uparrow key and press \leftarrow to store:

2 DIR : Enables flow measurement in 2 directions (fig. D.7).

TRAN. TIME : Output signal is proportional to the measured transit time of the acoustic signal.

NOTE:

This function requires:
 - PULSRATE setting, Fct. 3.4.2
 - PULSRATE at full flow, Fct. 3.4.3
 - Transit time at full flow, Fct. 3.1.2
 (see example in description of Fct. 3.1.2)

NO SIGNAL : Output signal indicates "signal loss".

OFF : No frequency output.

F/R IND. F : Output signal as flow direction indication, 0% at + flow direction and 100% at - flow direction (Fig. D.8).

1 DIR : Flow measurement in 1 direction (+) only (Fig. D.9).

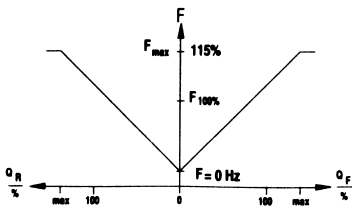

Fig. D.7 : Bi-directional flow(F)

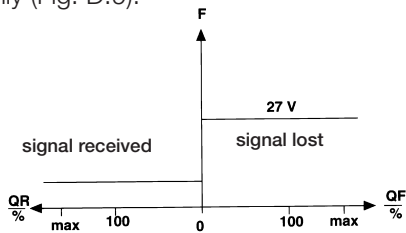

Fig. D.8: Flow direction indication(F)

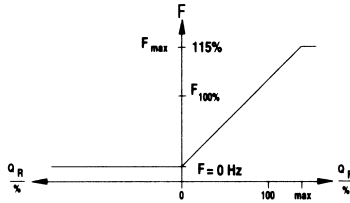



Fig.D.9: Positive flow (F)

3.4.2 PULSOUTP. : Frequency output mode

Select one of the two frequency output modes using the  key and press  to store:

PULSE/UNIT : Pulses per unit of volume.

PULSRATE : Pulses per unit of time at full scale flow.

Example of PULSE/UNIT :
 Pulse value : 10 pulses per m³ (set via Fct.3.4.3)
 After 60 m³ have passed : Output: 600 pulses since start.

Example PULSRATE :
 Full scale setting : 1000 liters per second (set via Start Up Menu)
 Pulse rate full scale flow : 1000 pulses per second (set via Fct. 3.4.3)
 At 600 liters per second : Output: 600 Hz signal.

3.4.3 PULS/UNIT - PULSRATE

(pulse/unit or pulse rate depends on selection in 3.4.2)

PULSE/UNIT : Program number of pulses per unit of volume:

Pulse per volumetric unit: Range (maximum):

PulS/m ³	9.9990 E 8
PulS/Liter	9.9990 E 5
PulS/US G	3.7850 E 6

PULSRATE : Program pulses per unit of time at full scale flow:

Pulse rate unit:	Range:	
	Min.	Max.
PulSe/Sec	2.7778 E-3	1.0000 E 4
PulSe/min	1.6667 E-1	6.0000 E 5
PulSe/hr	1.0000 E 1	3.6000 E 7

3.4.4 T - CONST. F : Time constant of frequency output (see 3.3.5 T- CONST.I)

Program one of the two options for the time constant of the frequency output:

T<F> = T<I> : Equal to the time constant of the current output (see 3.3.5).

T<F> = 40 msec



3.5.0 *SPEC. FCT.* : **set special functions**

3.5.1 *LANGUAGE* : Display language

Select a language option using the  key and press  to store:

GB/USA	:	English
D	:	German
F	:	French
NL	:	Dutch

3.5.2 *OUTP. HOLD* : Hold outputs during programming

If the flowmeter is not in the measuring mode no flow data is available and all output levels will normally drop to zero. With this function active all outputs maintain their last value before the measuring mode was exited.



This feature should be utilized at the user's discretion. Caution should be observed, if the signal is used in a control loop since the controller may have to be switched to "manual". In all cases, responsible personnel should be notified that the output is on "hold".

Select YES or NO using the  key and press  to store.

3.5.3 *UNIT TEXT*

With this function the name of the user defined unit can be programmed, e.g. Barrels/day.

The format of the unit is preprogrammed: -----/-----.

With both  and  keys the text (capital and numbers) can be programmed. Use  to store.

3.5.4 *FACT. QUANT.*

If a user defined unit is applied the quantity factor has to be programmed.

This must be the conversion ratio into m³.

In the example with Barrels/Day (see 3.5.3) the quantity unit Barrel has to be converted into m³ (1 Barrel = 1.5898 E-1 m³).

3.5.5 *FACT. TIME*

If a user defined unit is applied the time factor has to be programmed.

This must be the conversion ratio into seconds.

In the example with Barrels/Day (see 3.5.3) the time unit Day has to be converted into seconds (1 Day = 8.6400 E 4 seconds).

3.5.6 *SET DATE*

Program the correct date in this function.

The actual date is included in the header of each data block that is stored.

On entering this function the date can be programmed in (mm-dd-yy) notation.

Programming the actual date is similar to that of numbers.

3.5.7 *SET TIME*

Program the correct time in this function.

The actual time is included in the header of each data block that is stored.

Programming is similar to numbers.



3.5.8 *DEFAULT SET*

If this function is used all parameters will be reprogrammed to default settings (see Appendix 5).

(NOTE: factory settings are not affected by this function)

NOTE: The Date, Time and Location data will be lost, too !!

This function should only be used to restart programming if the cause of a PARAMERROR can not be found; it offers a start with no error messages as far as the parameters are concerned.

3.5.9 *SOFTW. V. NR.*

This function can be entered to view the number of the current software version.

No action can be taken here.

3.6.0 *COMM. DATA* : **set RS 232 output / store**

3.6.1 *OUTP. PARAM.*

With this function all programmed parameters can be sent to a PC via the RS 232 output.

NOTE: No error message is given if a communication error (no RS 232 response) occurs!

Select YES and press  to start the output.

3.6.2 *OUTP. DATA*

With this function all collected data stored in the RAM can be sent to a PC via the RS 232 output.

NOTE: No error message is given if a communication error (no RS 232 response) occurs!

Select YES and press  to start the output.

3.6.3 *SEL. COMM.*

With this function the output medium can be selected to which the data is sent as programmed in 3.2.0 and 3.6.4.; the intervals are programmed in 3.6.4.

The options are:

OFF	:	No output at all (only on LCD).
BOTH	:	Data is stored in the RAM as well as sent to the RS 232 output.
OUTPUT	:	Data is sent to the RS 232 output only.
STORE	:	Data is stored in the RAM only.

For settings of the PC terminal program see: C 4.3.



3.6.4 INTERVAL (not visible if SEL. COMM is OFF)

Program the interval between successive data collections as programmed in 3.6.3.

Range: 01 - 60 min

3.6.5 LOCATION : Location

If this function is activated the location, as programmed in the Start Up Menu, is recorded in the header of each data block that is stored or sent to RS 232.

Select YES or NO using the key and press to store.

3.6.6 RESET DATA

If STORE is programmed in function 3.6.3 all data blocks are stored in the internal RAM.

With this function the RAM can be cleared, to be able to store new data (up to 390 blocks).

NOTE: the parameter settings are not affected by this function.

Select YES or NO using the key and press to store.



D.5 Sub Menu : 2.0.0 TEST

2.1.0 DISPLAY

2.1.1 DISPLAY TEST

All individual segments of the liquid crystal display are activated in a sequence ending in a flashing display of all segments.

No action can be taken.

Select YES and press to start the test.

2.2.0 PROCESSOR

The microprocessor performs a self test.

No action can be taken.

Select YES and press to start the test.

If the test does not end with the message NO ERROR contact your dealer.

Press to exit the function.

2.3.0 CURR. OUTP. I

2.3.1 TEST

To check the functioning of both the analog output and the externally connected instruments and wiring, the analog output can be set to 7 specific values:

0, 4, 8, 12, 16, 20 and 22 mA

The value shown on the display should match the indication on the instrument connected to the current output.

Press to start the test and use the key to select output current.

Press to exit the function.



2.4.0 *FREQ. OUTPUT*

2.4.1 *TEST*

To check the functioning of both the frequency output and the externally connected instruments and wiring, the frequency output can be set to 5 specific values:

1, 10, 100, 1000 and 10000 Hz

The value shown on the display should match the indication on the instrument connected to the frequency output.

Press  to start the test and use the  key to select output frequency.

Press  to exit the function.



D.6 Parameter errors

If discrepancies in the parameters entered are found the microprocessor will display the message "PARAMERROR" thus preventing you from storing parameters that are incorrect.

The PARAMERROR menu can appear at the end of both the Start Up menu and the Installation Menu.

A third main menu is available now:
Fct. 4.0.0 PARAM.ERROR

In this menu only one submenu is available at a time; only the submenu that applies to the discrepancy to be corrected will be displayed.

List of possible submenus and functions within PARAMERROR:

4.0.0	PARAMERROR	Discrepancy:
4.1.0	V RANGE	The combination of the diameter, wall and lining thickness and the full scale flow rate is not feasible.
4.1.1	DIAMETER	
4.1.2	PIPEWALL	
4.1.3	LINING TH.	
4.1.4	FULL SCALE	
4.2.0	I RANGE	[I 100 PCT] does not exceed [I 0 PCT] by at least 4 mA
4.2.1	I 0 PCT	
4.2.2	I 100 PCT	
4.3.0	I MAX mA	[I MAX] is not equal to or greater than [I 100 PCT]
4.3.1	I 100 PCT	
4.3.2	I MAX	
4.4.0	CUTOFF	CUTOFF ON exceeds CUTOFF OFF

4.4.1	L.F. CUTOFF	
4.4.2	CUTOFF ON	
4.4.3	CUTOFF OFF	
4.5.0	F>10KHZ	Output frequency is too high, must be less than 10kHz
4.5.1	FULL SCALE	
4.5.2	PULSOUTP.	
4.5.3	PULSRATE	
4.5.4	PULS/UNIT	
4.6.0	APPL.DATA	Programmed sonic velocities are not within the specified range
4.6.1	PIPE MAT.	
4.6.2	LIQUID	
4.6.3	LINING MAT.	
4.7.0	FREQ.OUTPUT	The combination of F-Function and Pulsoutput is not feasible
4.7.1	FUNCTION F	
4.7.2	PULSOUTP.	

Activate the submenus and functions as described in section D.2.

After the correct parameter values have been entered the PARAMERROR menu can be exited by pressing the  key 7 times; the parameters are checked and saved and the program stops at the beginning of the Start Up menu.

NOTE: Instead of activating the PARAMERROR menu the INSTALLATION or TEST menus can be entered by using the  key.



E.1 Mains Fuse

The mains fuse is located in the connection compartment.

NOTE: ONLY USE FUSES AS INDICATED NEXT TO THE FUSE FITTING TO PREVENT SERIOUS DAMAGE TO THE ELECTRONIC EQUIPMENT (see Spare Parts).

If the fuse is blown regularly, contact your dealer.



F.1

General

Measuring beam	1
Diameter range	50 ... \geq 3000 mm (2" ... \geq 120")
Pipe wall thickness	\leq 40 mm (\leq 1.6")
Pipe wall materials	metal, plastics, ceramics, asbestos-cement with or without firmly attached linings or coatings
Fluids	any clean homogeneous liquid with a gaseous or solid particle content \leq 1% by volume
Fluid temp.	-25 to +120 °C (-13 to 248 °F)
Error limits	1 to 3%, depending on application
Reproducibility	up to 0.2%
Time constant	0.04 to 3600 s
Outputs	current, frequency/pulse and RS 232 for data transfer to PC
Display	for indication of all measuring data, calculated transducer distance, error messages and transit time
Measured values	volumetric flow rate, total flow, transit time and flow direction (forward/reverse)
Cable length:	
Standard	5 m (15 ft)
Optional	> 5 m... \leq 300 m (>15 ft... \leq 900 ft)

F.2 Transducers & Clamp-on Set

Transducers	single beam; 2x RS 600
Diameters	A single clamp-on set suitable for 50 mm (2") to 2000 mm (80") pipes, incorporating 2 rails with cm-scale and straps
Materials:	
Transducer housing	nickel plated brass with plastic contact surface.
Rails	aluminium, anodized
Protection category nec-(standard):	IP 65 (transducers with BNC connectors) acc. DIN 40050 / IEC 144
(option):	IP 68 (cables fix connected to the transducers)
Ambient temp.	-25 to 60 °C
Process liquid temp.	-25 to 120 °C

NOTE: High temperature sensor cable optional available.



F.3 **Signal Converter**

Version	UFC 600 T
Outputs	fully programmable galvanically insulated
- analog	0 to 20 mA, or 4 to 20 mA, or I[0%] to I[100%] programmable.
load	≤ 100 Ohm
- frequency/pulse pulse rate	0.0028 Hz.(= 10 pulses/hour) to 10000 Hz. or pulses per liter, m3, US gallon, or per user defined unit
Low flow cut off	programmable in : 1 to 19% out: 2 to 20%

Local display:	back-lit LCD
Display functions	actual flow rate, forward-, reverse- and sum-totalizers (7 digit), transition time and error messages; each programmable for continuous or sequential display
Display units	
actual flow	liters, m ³ , or US gallons per second, minute or hour and one free programmable unit
totalizers	liters, m ³ , or US gallons and one freely programmable unit; min. one year overflow time
Display language	English, French, German, Dutch; other languages on request
Display arrangement	8 digit , 7 element numerical and sign display,
1st line	symbols for push-button acknowledgement
2nd line	10 character 14 segment text display.
3rd line	4 markers to identify the actual display function
functions	location, actual flow rate (and direction), totalizer, time, transit-time and error messages



Power supply

AC power supply: 85 - 264 VAC
DC power supply: 18 - 32 VDC

Power consumption ≤ 10 VA AC
 ≤ 8 W DC

Housing Cast aluminium

Ambient temp. -25 to +50 °C (-13 to 122°F)

Protection category IP 65, acc. to IEC 529
(equivalent to NEMA 4x)

Full scale value (Din= inner pipe diameter)

lower limit ($V_{100\% \min} = 0.5 \text{ m/s}$)

$$Q_{100\% \min} [\text{m}^3/\text{h}] = (\text{Din} [\text{mm}]/100)^2 * 14.2$$

$$Q_{100\% \min} [\text{m}^3/\text{h}] = (\text{Din} [\text{inch}])^2 * 0.9$$

$$Q_{100\% \min} [\text{USGPM}] = (\text{Din} [\text{inch}])^2 * 3.9$$

upper limit ($V_{100\% \max} = 17.1 \text{ m/s}$)

$$Q_{100\% \max} [\text{m}^3/\text{h}] = (\text{Din} [\text{mm}])^2 * 0.05$$

$$Q_{100\% \max} [\text{m}^3/\text{h}] = (\text{Din} [\text{inch}])^2 * 31.25$$

$$Q_{100\% \max} [\text{USGPM}] = (\text{Din} [\text{inch}])^2 * 138$$

Reynolds number $\text{Re} > 10.000$

Repeatability

$$R = \frac{0.2}{V_m * D_i} \quad [\%]$$

R = repeatability in %
 V_m = flow velocity [m/s]
 D_i = inner pipe diameter [m]



APPENDIX 1 : Pipe Material Sonic Velocities

MATERIAL NAME	SONIC VELOCITY
Carbon Steel $c \leq 0.3\%$	3064 m/s
Carbon Steel $c > 0.3\%$	3173 m/s
Carbon-Moly Steel	3173 m/s
Cr-Mo-Steel $Cr \leq 3\%$	3173 m/s
Cr-Mo-Steel $5\% \leq Cr \leq 9\%$	3040 m/s
Chromium Steel (stainless)	3177 m/s
Austenitic St. Steel (general)	3120 m/s
St. Steel 304	3120 m/s
St. Steel 310	3120 m/s
St. Steel 316	3120 m/s
St. Steel 321	3120 m/s
St. Steel 347	3120 m/s
Grey Cast Iron	2125 m/s
Monel 67 Ni- 30 Cu	2810 m/s
Monel 66 Ni- 29 Cu- Al	2823 m/s
Alloy 706 (90 Cu - 10 Ni)	2334 m/s
Alloy 710 (80 Cu - 20 Ni)	2582 m/s
Alloy 715 (70 Cu - 30 Ni)	2513 m/s
Copper Alloys 120 and 122	2149 m/s
Lead-Tin-Bronze alloy 922 A9	1985 m/s
Commercial Brass (65 Cu-35 Zn)	2060 m/s
Aluminium	3269 m/s
Incoloy 800/800H Ni-Fe-Cr	3024 m/s
Inconel 600 Ni-Cr-Fe	3004 m/s
Commercial pure Titanium	2975 m/s
PP	2120 m/s
PVC	2120 m/s
Perspex	2730 m/s
Asbestos Cement	4195 m/s

APPENDIX 2 : Sonic Velocities of Liquids

LIQUID NAME	SONIC VELOCITY at 20°C
Acetone	1174 m/s
Benzene	1295 m/s
Carbon Disulphide	1149 m/s
Caster Oil	1477 m/s
Chloroform	987 m/s
Diesel Oil	1250 m/s
Ethanol	1207 m/s
Ethanol Amide	1724 m/s
Ethyl Ether	985 m/s
Ethylene Glycol	1658 m/s
Freon	690 m/s
Glycerol	1904 m/s
Kerosine	1324 m/s
Mercury	1407 m/s
Methanol	1103 m/s
Methylene Iodide	980 m/s
Nitrobenzene	1460 m/s
Turpentine	1326 m/s
Water (0 - 20°C)	1484 m/s
Water (21- 40°C)	1505 m/s
Water (41 - 60°C)	1529 m/s
Water (61 - 80°C)	1538 m/s
Sea Water	1531 m/s
Xylene Hexafluoride	879 m/s

APPENDIX 3 : Sonic velocity calculation Using Indicated Transit Time

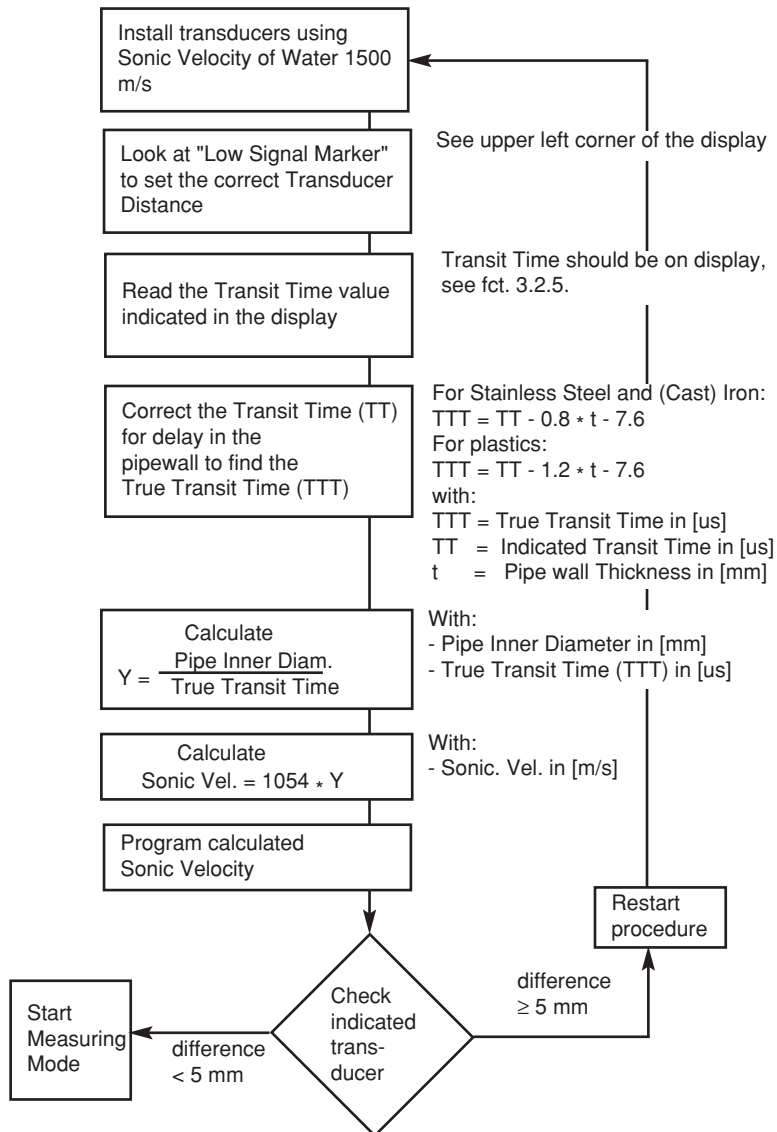

APPENDIX 4 : Exponential Notation

Most values have to be entered in the exponential notation as will be made clear by the message displayed.

Exponential Notation: Y.YYYY E±Z

This indicates that Y.YYYY should have a value between 1.0000 and 9.9999 ($1.0000 < Y.YYYY < 9.9999$).

The value of Z gives the multiplication factor, e.g.:

Z = +0 indicates Y.YYYY x 1
Z = +1 indicates Y.YYYY x 10
Z = +2 indicates Y.YYYY x 100
Z = +3 indicates Y.YYYY x 1000
etc.

For small values the exponent Z will be negative.
(Press ARROW UP when E is blinking)

Z gives the dividing factor, e.g.:
Z = -1 indicates Y.YYYY / 10
Z = -2 indicates Y.YYYY / 100
Z = -3 indicates Y.YYYY / 1000
etc.

Examples:

program:	1.0345	as	1.0345 E+0
	16.167	as	1.6167 E+1
	550.12	as	5.5012 E+2
	2987.1	as	2.9871 E+3

and with negative exponents:

0.335	as	3.3500 E-1
0.0205	as	2.0500 E-2
0.0015	as	1.5000 E-3

APPENDIX 5 : Default Settings + Example of Output Parameters

The next page shows all parameters after the function Default Set (3.5.8) has been used. These are the default settings as programmed by the factory.

The way the settings are presented is identical to the RS 232 output after using function Output Parameters (3.6.1).

1.0.0.	STARTUP DIAMETER	1.0000E+2 mm
	PIPE WALL	1.0000E+0 mm
	PIPE MAT.	3.1700E+3
	LINING	NO
	LIQUID	1.5000E+3 WATER
	FULL SCALE	1.0000E+2 m ³ /hr
	LOCATION	
	SENS. DIST.	4.4329E+1 mm
	ZERO SET.	
3.0.0.	INSTALL.	
3.1.0	FLOW DATA	
3.1.1	PRIM. CORR.	1.0000E+0
3.1.2	TRAN. RANGE	3.0000E+2 uSec
3.1.3	L.F. CUTOFF	YES
3.1.4	CUTOFF ON	01%
3.1.5	CUTOFF OFF	02%
3.2.0	DISPLAY	
3.2.1	DISP. FLOW	m ³ /hr
3.2.2	DISP. TOTAL.	+ TOT
3.2.3	UNIT TOTAL	m ³
3.2.4	ERROR MSG.	
	NO MESSAGE	
3.2.5	DISP. TRAN. T.	NO
3.2.6	CYCL. DISP.	NO

3.3.0.	CURR. OUTPUT FUNCTION I	1 DIR.
3.3.1		
3.3.2	I 0 PCT.	04 mA
3.3.3	I 100 PCT.	20 mA
3.3.4	I MAX mA	22 mA
3.3.5	T-CONST.	4.0000E+0 Sec
3.4.0	FREQ. OUTPUT FUNCTION F	1 DIR.
3.4.1		
3.4.2	PULSOUTP.	PULS/UNIT
3.4.3	PULS/UNIT	1.0000E+0 Puls/m ³
3.4.4	T-CONST.	40 mSec
3.5.0	SPEC. FCT.	
3.5.1	LANGUAGE	GB/USA
3.5.2	OUTP. HOLD	NO
3.5.3	UNIT TEXT	—/—
3.5.4	FACT. QUANT.	1.0000E+0
3.5.5	FACT. TIME	1.0000E+0
3.5.6	SET DATE	01-01-90
3.5.7	SET TIME	12:00:00
3.6.3	SEL. COMM.	OFF
3.6.6	RESET DATA	

APPENDIX 6 : Spare Parts

Krohne ordering number	Description	Number per UFM 600 T	Type/remarks
230262- 01	Mounting Rail	2	UL 600R (with slots)
231266- 01 (coded)	Cable, coax	1	5 m, BNC-connectors
231266- 02	Cable, coax	1	5 m, BNC-connectors
231266- 03 (coded)	Cable, coax	(1)	10 m, BNC-connectors
231266- 04	Cable, coax	(1)	10 m, BNC-connectors
230271- 02	Transducer	2	UL 600 R
230306- 02	Sonic coupling grease	1	Tube, Blasolube, 70 g
53089001	Tape measure	1	500 cm (192")
53063201	Small Mounting strap	2	60-215
53063203	Large Mounting strap	4	60-540
231021- 06	Disc	1	UFM 600/ 3 1/2" Disc
50567800	Fuse	1	T zoom A, 20 x 5 mm 85V -264 VAC
50782300	Fuse, main	1	T 1.6 mA, 20 x 5 mm
7.3071831	Manual	1	UFM 600 T
53133301	Cable RS232	1	
S 153000364	Ultrasonic wall thickness gauge	(1)	T-Mike, incl. probes, AC/DC converter, couplant gel

NOTE: Numbers between brackets (..) are not part of standard delivery.