

V500 Single Support & V510 Double Support – Flanged Components

The Most Accurate and Reliable Technology for Measuring Gas, Liquid and Steam...

Developed from aerospace technology, the VERIS Verabar® averaging pitot flow sensor provides unsurpassed accuracy and reliability.

With its solid, one-piece construction and bullet shape, the VERIS Verabar® makes flow measurement leak resistant and precise. The unique sensor shape reduces drag and flow induced vibration. The location of the low-pressure ports significantly reduces the potential for clogging and improves signal stability.



V500



V510

V500 Single Support & V510 Double Support	
Pipe Connection	Flanged
Mounting Type	Flanged up to ANSI Class 2500#
Features and Benefits	<ul style="list-style-type: none"> • All welded mounting • Preferred mounting in power, petrochemical and refining industries • Can mount to existing flanges
Applications	<ul style="list-style-type: none"> • Air • Natural gas • Hydrocarbon liquids and gases • Water (raw, cooling, feedwater) • Hazardous fluids • Steam • Large pipes and ducts
Special Designs - Consult Factory	<ul style="list-style-type: none"> • Custom mounting, lengths, materials, instrument connections, etc. • Short straight run

Temperature Pressure Limits (ANSI Class)*
150#
275 psig @ 100°F (19 bar @ 38°C)
80 psig @ 800°F (5.5 bar @ 426°C)
300#
720 psig @ 100°F (49.6 bar @ 38°C)
410 psig @ 800°F (28.3 bar @ 426°C)
600#
1440 psig @ 100°F (99.3 bar @ 38°C)
825 psig @ 800°F (56.9 bar @ 426°C)
1500#
3600 psig @ 100°F (248.2 bar @ 38°C)
190 psig @ 1500°F (13.1 bar @ 815°C)
2500#
6000 psig @ 100°F (413.7 bar @ 38°C)
315 psig @ 1500°F (21.7 bar @ 815°C)

Model Specifications	V500 and V510		
Sensor Code	05	10	15
Sensor Diameter	7/16" (11mm)	7/8" (22mm)	1-3/8" (35mm)
Accuracy	±1% of flow rate; up to +/-0.5% if calibrated		
ANSI Class*	150#, 300#, 600#, 1500# and 2500#		
Pipe Size	2" - 6" (50mm-150mm)	6" - 48" (150mm-1200mm)	12" - 192" (300mm-5000mm)
Instrument Connection	1/2" NPT, Socket Weld or Direct Mount		
Components Furnished	Weld coupling, weldneck flange, gasket, studs & nuts V510 includes additional weld coupling and pipe cap		
Flange Size	1"	1-1/2"	2"

* DIN and JIS flanges available. Consult factory.



1. Enter Pipe Dimensions or Duct Dimensions

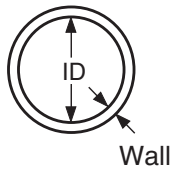

Pipe Size _____ Sch _____
 Pipe ID _____ and
 Wall _____ Pipe Material _____

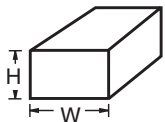

Height (H) _____
 Width (W) _____
 Wall _____
 Duct Material _____

Dimension
 Verabar® spans
 (H) or (W)

2. Pipe or Duct Orientation (Check one box)

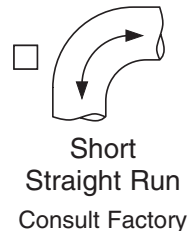
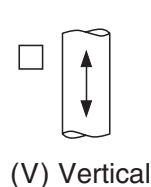
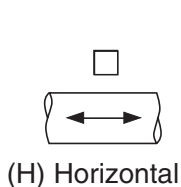

3. Enter Flow Conditions

Fluid Name:		Maximum	Nominal	Minimum	Units
Flow Rate					
All Fluids	Pressure @ Flow				
	Temperature @ Flow				
Gas	Specific Gravity, or Molecular Weight				
Liquid	Specific Gravity				
Steam	VeraCalc Program can calculate Density from Temperature and Pressure				

4. Select Model from Page 3

Use the Ordering Information table on Page 3 to determine your model number.

5. Flow Calculation

All VERIS Verabar® applications require a flow calculation to verify the DP, pressure and temperature limits, structural limits and to size the transmitter. VeraCalc is for use by representatives and end users. It is easy to operate and includes steam tables.

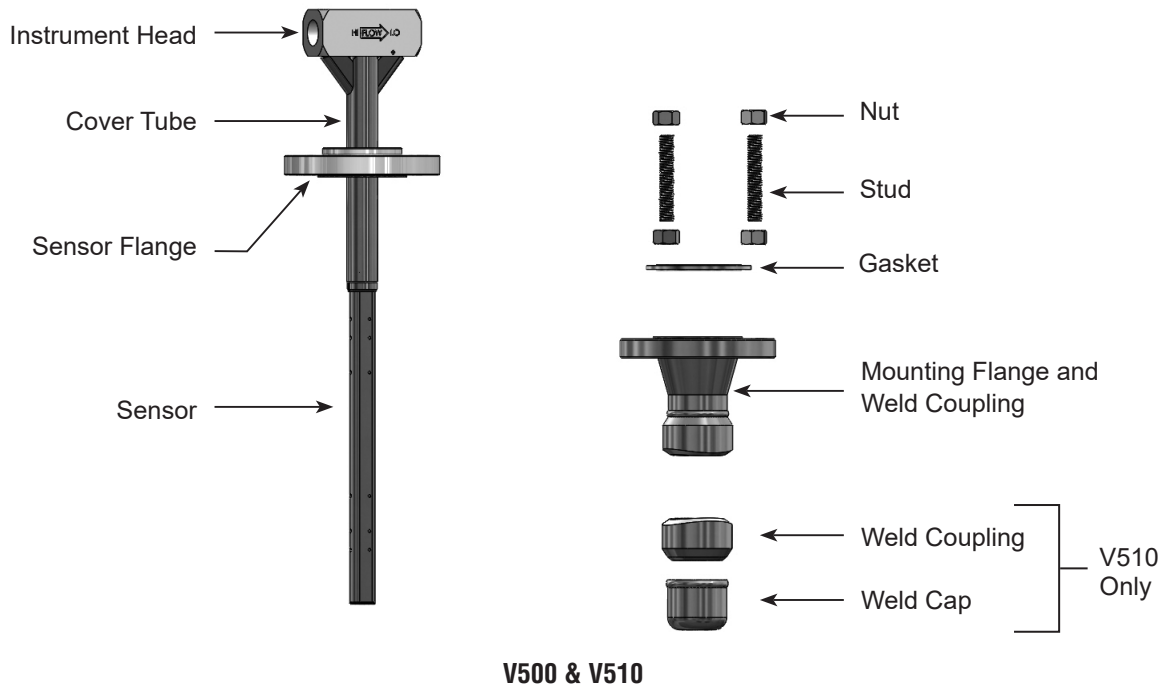

High Pressure and Temperature Head Option

Unique Design Features

High Pressure Threaded (HPT) and High Pressure Socket (HPS) designs offer the highest possible pressure and temperature capabilities. When pressure containment and safety are primary concerns, the HPT/HPS has the strongest and safest design in the industry.

As with all VERIS designs, it meets ANSI/ASME B31.1 and can be supplied with code welding (ASME Section IX), hydrostatic testing, N.A.C.E. and material traceability.

Applications

Main Header Steam Lines

Used for high pressure and temperature applications such as main header steam lines.

For these applications, pipe mounting assemblies are available in chrome-moly material (ASTM A182 F11, F22 & F91).

Other Applications

- High pressure and temperature gases and liquids
- Natural gas transmission lines
- Boiler feed water lines
- Oil well injection lines

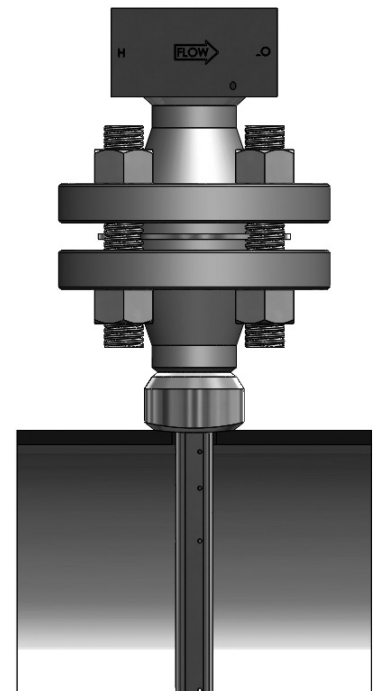

Applications up to ANSI Class 2500#

Model	Flanged
V500	Single Support
V510	Double Support

Pipe Size and Schedule or Exact ID and Wall Thickness

Code	Sensor Pipe Size Range
05	2" to 6" (50mm to 150mm)
10	6" to 48" (150mm to 1200mm)
15	12" to 192" (300mm to 5000mm)

Code	Pipe Orientation
H	Horizontal
V	Vertical

**Instrument Connections (Select Remote or Direct Mount)
(Transmitter sold separately)**

Remote Mount Transmitter (1/2" NPT)				Direct Mount Transmitter (Flanged 450°F/232°C Max.)†		
Parallel	Regular	RTD*	Valve	Transmount	Mass Transmount	Manifold
P	R	D	T Integral	F	G Integral RTD	M Integral

Instrument Valves (Opt.)		Manifolds (Optional)			
Remote Mount		Direct Mount			
Needle	Gate	3-Valve		5-Valve	
1/2" NPT	1/2" NPT	Soft Seat	Hard Seat	Soft Seat	Hard Seat
C2NC (CS) C2NS (SS)	C2GC (CS) C2GS (SS)	F3SC (CS) F3SS (SS)	F3HC (CS) F3HS (SS)	F5SC (CS) F5SS (SS)	F5HC (CS) F5HS (SS)

Optional

Mounting Assembly — Select Material & Rating (Includes SS sensor flange, WN flange, weld coupling, spiral-wound gaskets, studs & nuts)					
Sensor (Flange Size)			Mating Flange Material & ANSI Class		
05 (1")	10 (1-1/2")	15 (2")			
Code					
F415C	F615C	F815C	CS	#150	
F415S	F615S	F815S	SS	#150	
F430C	F630C	F830C	CS	#300	
F430S	F630S	F830S	SS	#300	
F460C	F660C	F860C	CS	#600	
F460S	F660S	F860S	SS	#600	

High Pressure Instrument Head (ANSI Class 1500# & 2500#)				
HPT	1/2" NPT			
HPS	Socket Weld			
High Pressure Mounting Assy (HPT & HPS Connections)				
Sensor (Flange Size)			Mating Flange Material & ANSI Class	
05 (1")	10 (1-1/2")	15 (2.5" or 3")		
Code				
F4150C	F6150C	F10150C	CS	1500#
F4150S	F6150S	F10150S	SS	
F4150F11	F6150F11	F10150F11	F11	
F4150F22	F6150F22	F10150F22	F22	
F4250C	F6250C	F12250C	CS	2500#
F4250S	F6250S	F12250S	SS	
F4250F11	F6250F11	F12250F11		
F4250F22	F6250F22	F12250F22		

V500	8"sch40	10	H	R	C2NC	F615C	Typical Model Number
-------------	----------------	-----------	----------	----------	-------------	--------------	-----------------------------

* For high pressure (>500psig) or high temperature (>500°F), remote mount RTD in a thermowell is preferred.

† Assuming adequate heat dissipation for transmitter.

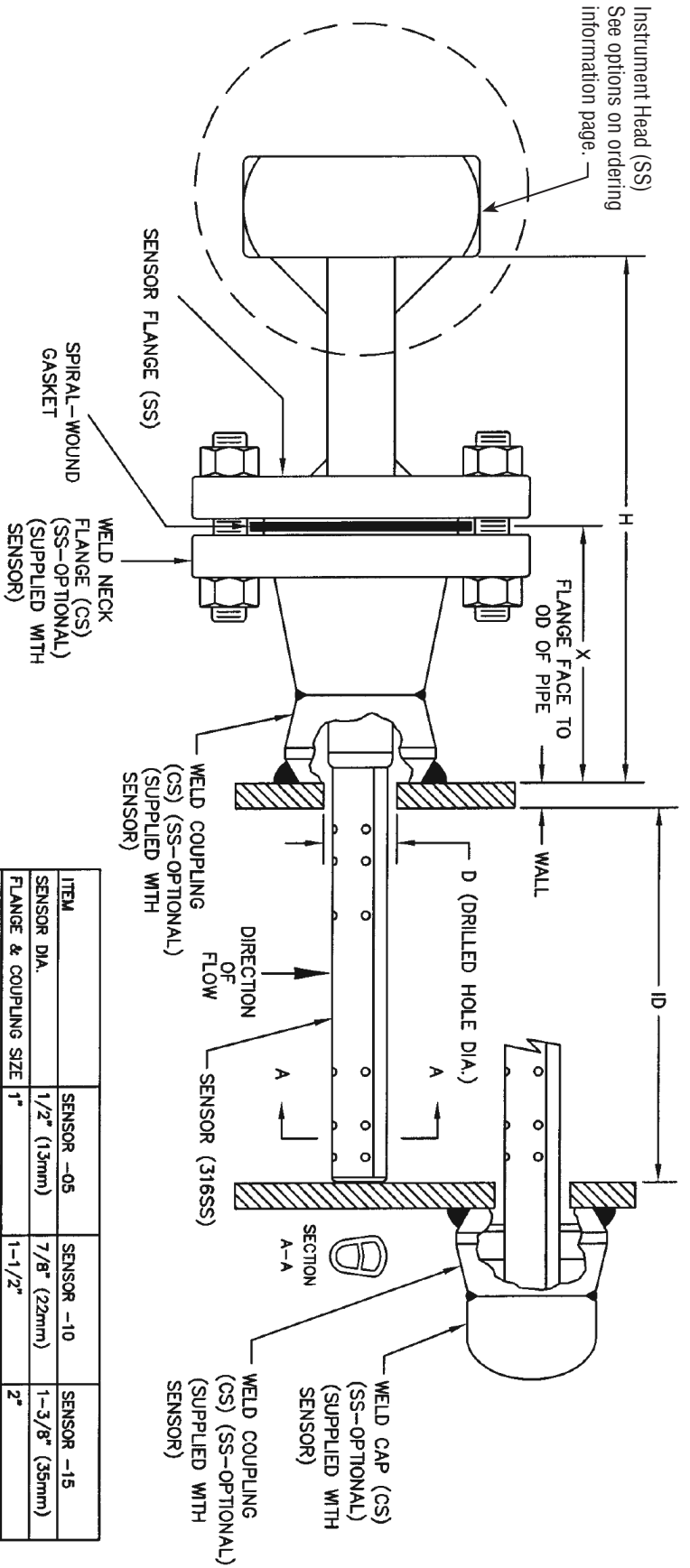

NOTES:
 1. CONTACT VERIS FOR DIMENSIONAL DRAWING FOR HIGH PRESSURE THREADED (HPT) & HIGH PRESSURE SOCKET (HPS)

ITEM	SENSOR -05	SENSOR -10	SENSOR -15
SENSOR DIA.	1/2" (13mm)	7/8" (22mm)	1-3/8" (35mm)
FLANGE & COUPLING SIZE	1"	1-1/2"	2"
DIM D* DRILLED HOLE DIA.	1/2" (13mm)	1" (26mm)	1-1/2" (39mm)
DIM H** ANSI CLASS 150#	6.7" (170mm)	7.9" (200mm)	9.3" (235mm)
DIM H** ANSI CLASS 300#	7.3" (186mm)	8.4" (214mm)	9.8" (249mm)
DIM H** ANSI CLASS 600#	7.8" (198mm)	9.1" (230mm)	10.6" (268mm)
DIM X** ANSI CLASS 150#	3.31" (84mm)	3.81" (97mm)	4.06" (103mm)
DIM X** ANSI CLASS 300#	3.56" (90mm)	4.06" (103mm)	4.31" (110mm)
DIM X** ANSI CLASS 600#	3.81" (97mm)	4.38" (111mm)	4.69" (119mm)

* H* & X* DIMENSIONS ARE APPROXIMATE (FOR SIZING PURPOSES ONLY)

 Armstrong VERIS Flow Measurement Group armstronginternational.com/veris	VERIS Verabar® V500 / V510 Flanged Connection
DATE: 09/20/01	DWG. No. SUB-3941
Scale: NTS	Rev: A
	Page 1 of 1



Armstrong VERIS Flow Measurement Group
 6315 Monarch Park Pl, Niwot, CO 80503 - USA Phone: 303-652-8550 Fax: 303-652-8552
armstronginternational.com