

Series SD

User's Manual

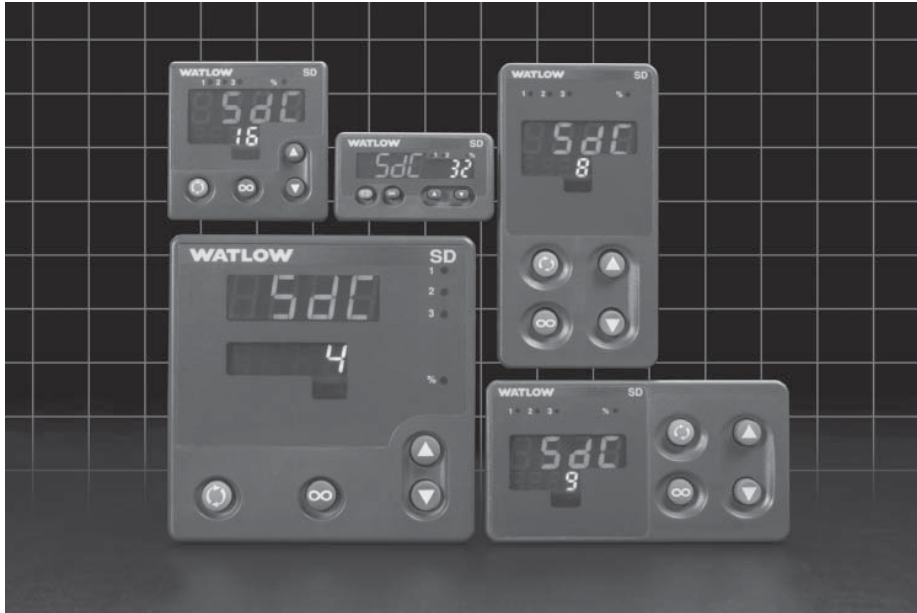

PID Controller and PID Profiling Controller



**TOTAL
CUSTOMER
SATISFACTION**
3 Year Warranty



ISO 9001



Registered Company
Winona, Minnesota USA

1241 Bundy Boulevard., Winona, Minnesota USA 55987
Phone: +1 (507) 454-5300, Fax: +1 (507) 452-4507 <http://www.watlow.com>

0600-0041-0000 Rev. F

Made in the U.S.A.



April 2006

\$15.00

Safety Information

We use note, caution and warning symbols throughout this book to draw your attention to important operational and safety information.

A “NOTE” marks a short message to alert you to an important detail.

A “CAUTION” safety alert appears with information that is important for protecting your equipment and performance. Be especially careful to read and follow all cautions that apply to your application.

A “WARNING” safety alert appears with information that is important for protecting you, others and equipment from damage. Pay very close attention to all warnings that apply to your application.

The safety alert symbol,  (an exclamation point in a triangle) precedes a general CAUTION or WARNING statement.

The electrical hazard symbol,  (a lightning bolt in a triangle) precedes an electric shock hazard CAUTION or WARNING safety statement.



**CAUTION or
WARNING**

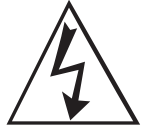

**Electrical
Shock Hazard**

CAUTION or WARNING

Technical Assistance

If you encounter a problem with your Watlow controller, review your configuration information to verify that your selections are consistent with your application: inputs, outputs, alarms, limits, etc. If the problem persists, you can get technical assistance from your local Watlow representative (see back cover), by e-mailing your questions to wintechsupport@watlow.com or by dialing +1 (507) 494-5656 between 7 a.m. and 5 p.m., Central Standard Time (CST). Ask for for an Applications Engineer. Please have the following information available when calling:

- Complete model number
- All configuration information
- User’s Manual
- Factory Page

Warranty

The Series SD is manufactured by ISO 9001-registered processes and is backed by a three-year warranty.

Return Material Authorization (RMA)

1. Call Watlow Customer Service, (507) 454-5300, for a Return Material Authorization (RMA) number before returning any item for repair. If you do not know why the product failed, contact an Application Engineer or Product Manager. All RMA’s require:

- Ship to address
- Contact name
- Method of return shipment
- Detailed description of the problem
- Name and phone number of person returning the product.
- Bill to address
- Phone number
- Your P.O. number
- Any special instructions

2. Prior approval and an RMA number from the Customer Service Department is required when returning any product for credit, repair or evaluation. Make sure the RMA number is on the outside of the carton and on all paperwork returned. Ship on a Freight Prepaid basis.

3. After we receive your return, we will examine it and try to verify the reason for returning it.

4. In cases of manufacturing defect, we will enter a repair order, replacement order or issue credit for material returned. In cases of customer mis-use, we will provide repair costs and request a purchase order to proceed with the repair work.

5. To return products that are not defective, goods must be in new condition, in the original boxes and they must be returned within 120 days of receipt. A 20 percent restocking charge is applied for all returned stock controls and accessories.

6. If the unit is unrepairable, you will receive a letter of explanation. and be given the option to have the unit returned to you at your expense or to have us scrap the unit.

7. Watlow reserves the right to charge for no trouble found (NTF) returns.

The Series SD User’s Manual is copyrighted by Watlow Winona, Inc., © February 2006 with all rights reserved.

Table of Contents

- Chapter 1: Overview.....2**
- Chapter 2: Install and Wire.....4**
 - Dimensions4
 - Installation.....6
 - Wiring the Series SD11
- Chapter 3: Keys and Displays.....20**
 - Home Page Overview21
 - Operations Page Overview22
 - Setup Page Overview23
 - Programming Page Overview24
 - Factory Page Overview24
- Chapter 4: Home Page.....25**
- Chapter 5: Setup Page.....26**
- Chapter 6: Operations Parameters Table36**
- Chapter 7: Operations Parameters Table for TRU-TUNE+™40**
- Chapter 8: Programming Page43**
- Chapter 9: Programming Page for TRU-TUNE+™45**
- Chapter 10: Profiling Page47**
- Chapter 11: Factory Page.....59**
- Chapter 12: Features.....61**
 - Saving and Restoring User Settings.....62
 - Saving and Restoring User Profiles.....62
 - Operations Page62
 - Tuning the PID Parameters63
 - Inputs64
 - Control Methods.....66
 - Alarms70
 - Retransmit.....71
 - Communications71
- Appendix77**
 - Specifications77
 - Ordering Information and Model Numbers79
 - Prompt Index.....80
 - Index80

1

Chapter 1: Overview

The Watlow Series SD family of PID, microprocessor-based temperature controllers is available in 1/32, 1/16, 1/8 and 1/4 DIN panel mount sizes.* The product family includes a static set point PID control version, a PID profiling (ramp and soak) version and an FM approved limit version. All models have a single, universal input that accepts various thermocouples, RTDs (resistive temperature devices) or process inputs. (See the Specifications in the Appendix for further details).

The Series SD PID controllers offer up to two outputs on the 1/32 DIN, and up to three outputs on all others. Outputs can be configured as heat, cool, alarm or off (deactivated). The control outputs can be independently configured for PID or On-Off control. PID settings include proportional band, reset (or integral) and rate (or derivative).

The Series SD PID profiling (ramp and soak) controllers are available as a factory order option for any of the Series SD DIN sizes. The profiling feature allows the user to program up to 4 profiles of 10 steps each. The files can be linked to support a single file of up to 34 unique steps. The Series SD profiling units can also operate as a closed loop static set point controller or manual mode (open loop, percent power) operation capabilities. Outputs can be configured as heat, cool, alarm, event or off (deactivated).

Standard Series SD features include an IP65/NE-MA 4X front panel rating; CE compliance, UL, CUL, CSA and NSF agency approvals; dual, four-digit displays in red or green**; autotuning for heat and cool outputs; ramp to set point, to gradually warm up your thermal system; and automatic/manual capability with bumpless transfer. A low-voltage model is also available.

Advanced features include Modbus, EIA-485 serial communications to interface with PC software applications; INFOSENSE™ technology that provides low-cost, high-accuracy thermal sensing; and infrared remote communication for easy-to-use controller setup and monitoring.***

Other operator-friendly features include LED indicators to aid in monitoring and setting up the controller, as well as a calibration offset at the front panel. The Watlow Series SD family automatically stores all information in non-volatile memory and provides an additional back-up for user-selected settings.

For more information on these and all other product features, refer to the Features chapter and the Appendix.

* Also available in an FM-approved limit version.

** The 1/32 DIN controller comes only with a red left and green right display.

*** Infrared option not available on 1/32 DIN.

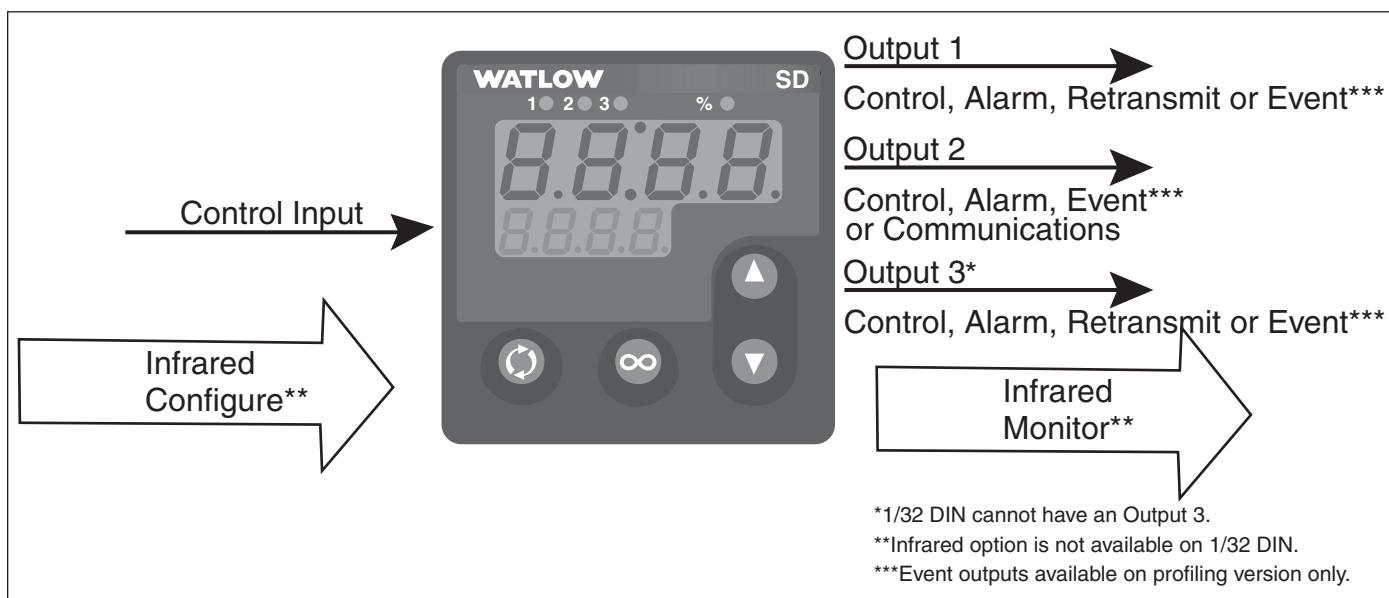

Figure 2 — Series SD inputs and outputs.

Features and Benefits

INFOSENSE™ Technology

- Improves sensor accuracy by a minimum of 50%.

User Definable Menu System

- Simplifies operator interface

User Definable Default Settings

- Restores to user defined controller settings

WATVIEW™ Software

- Operation, configuration and data logging with a standard Windows® PC.

Infrared Communications

- Facilitates controller setup, operation and monitoring.

Up to three outputs (1/32 DIN two outputs only)

- Application versatility.
- Configuration flexibility.

Dual Displays on all models

- Better monitoring of process changes.

Ramp to Set Point

- Controls the rate of temperature changes.

Profiling (ramp and soak) Capability

- 4 Profiles with 10 steps each
- Profiles can be linked together
- wait-for Process
- Guaranteed Soak
- Programmable Event Outputs
- Customer/OEM Profile save/restore

Available in an FM-approved limit version.

How to use the Series SD controller

Before you use your Series SD controller, it must be installed and configured correctly. **The setup steps you need to perform will depend on how you will use it.**

If you purchased the controller to design into your products:

You will need to do the first three steps and maybe some of the fourth step. Some wiring, such as the final wiring of a communications connection or an alarm output for signaling an external device, might be left to the end user. In highly specialized applications with little variation in operation and heat load, the OEM might configure almost all the parameters.

If you purchased the controller to design and install into new equipment for your own use or to retrofit into existing equipment:

You will need to complete all four steps.

If you purchased the controller installed in equipment designed around it:

You will probably only need to do the fourth step. In some instances, you may need to wire it for serial communications and/or an alarm output. Some serial communications parameters on the Setup Page may need to be changed.

Step 1: Mount and install the controller.

The Series SD controller is designed to be panel mounted in a standard DIN opening. The Series SD is available in 1/32 DIN, 1/16 DIN, 1/8 DIN-horizontal, 1/8 DIN-vertical and 1/4 DIN sizes. Cut the correct size hole into the panel and mount the controller, using its mounting brackets. See the Install and Wire chapter for details on installation and mounting.

If you retrofit the Series SD controller into an existing application, you may need to modify an existing opening, either by cutting it larger for a larger controller or using a Watlow adapter plate to adapt it to a smaller controller.

Step 2: Wire the controller.

The controller will need to have its power, input and output wiring installed. The wiring depends on the specific model number of the Series SD controller. The dimension illustrations in the Install and Wire chapter show the location of the model number on each DIN size. Use the model number to determine which wiring diagrams to follow for your controller. See the Install and Wire chapter for wiring details.

Step 3: Configure the Setup Page.

Setup Page parameters tell the controller what input and output devices are wired to the controller and how the controller should function. Without the proper Setup Page settings, the controller will not operate or could operate erratically. Since these settings require detailed knowledge on the wiring and operation of the equipment, the OEM or the designer normally programs these parameters. Some settings, such as the baud rate or controller address, are Setup Page parameters, but would probably be set by the end user.

These settings should be recorded for future reference. The settings can also be stored using the **USr.S** parameter, on the Factory Page. For saving and restoring parameters, see the Features chapter. For details on configuring the Setup Page, see the Setup Page chapter.

Step 4: Configure the Operations Page.

The Operations Page contains the parameters that the equipment operator may need to set or change from time to time. This includes calibration offset, autotune, PID parameters and alarm set points. In some cases the OEM manufacturer may set most of these parameters because the equipment operates with little variation. In equipment where demands could vary significantly, the OEM may leave parameter adjustments to the end user.

The Operations Page on the Series SD controller is customizable so that only the parameters that the operator may need to use will appear in the display. Settings that won't need to be adjusted can be hidden from the operator, using the Programming Page. For more details on the Programming Page, see the Features chapter. For details on configuring parameters in the Operations Page, see the Operations Parameters Tables. Once you have verified the controller is operating properly, be sure to document all of your parameter settings. **Each parameter table has a settings column for you to write in your values.**

2

Chapter 2: Install and Wire

Dimensions

1/32 DIN Series SD Controller Dimensions

Front

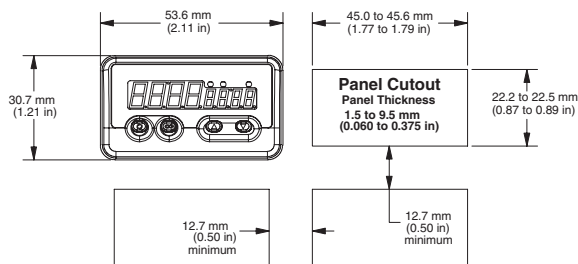

Top

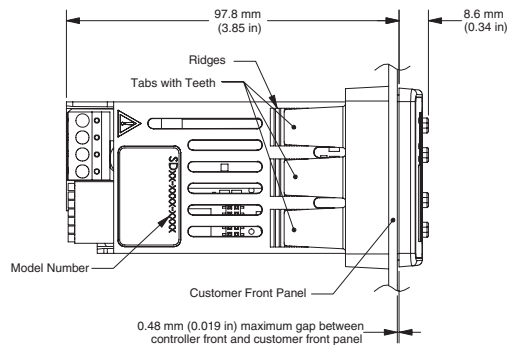

Back

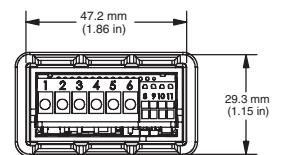

Contact your local Greenlee supplier for the appropriate punch kit and cutout tools required for rapid mounting.

1/16 DIN Series SD Controller Dimensions

Front

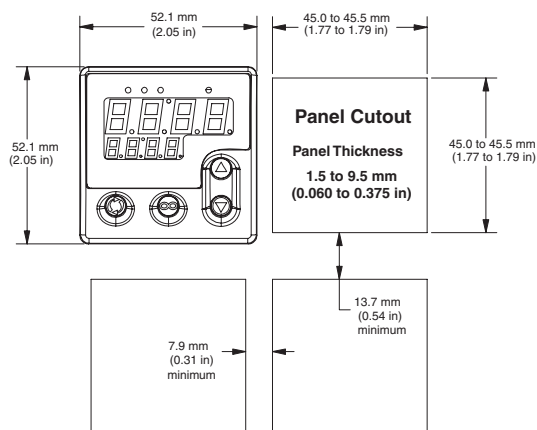

Side

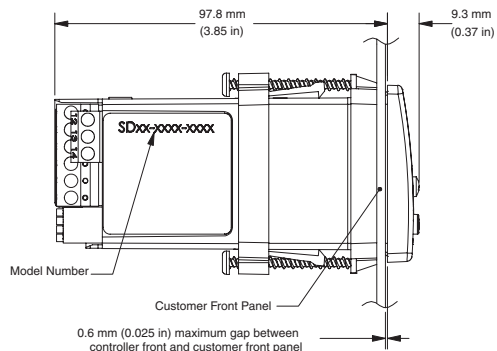

Back

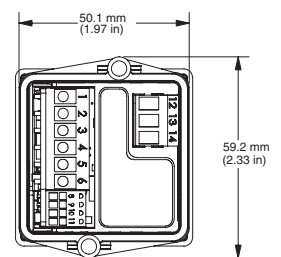

Contact your local Greenlee supplier for the appropriate punch kit and cutout tools required for rapid mounting.

1/8 DIN Series SD Controller Dimensions

Front (horizontal)

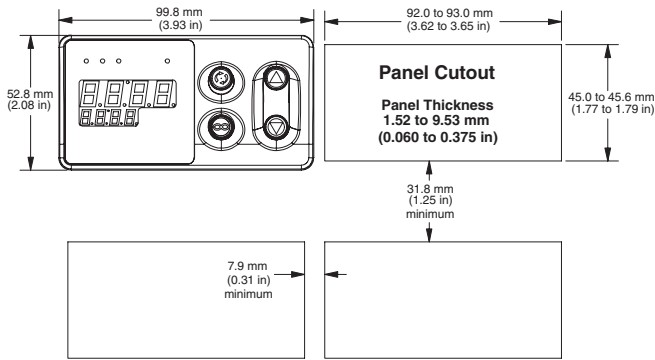

Front (vertical)

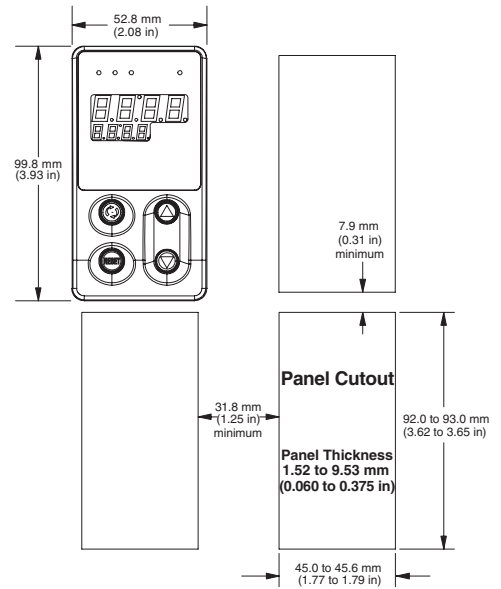

Back (horizontal)

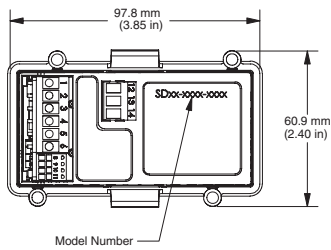

Back (vertical)

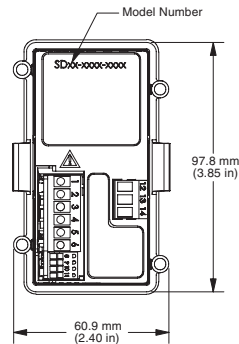

Side (horizontal)

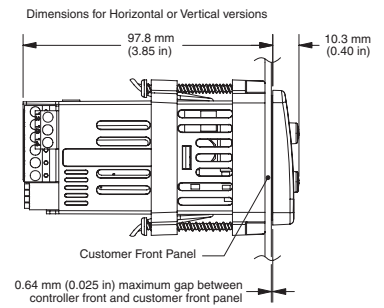

Contact your local Greenlee supplier for the appropriate punch kit and cutout tools required for rapid mounting.

1/4 DIN Series SD Controller Dimensions

Front

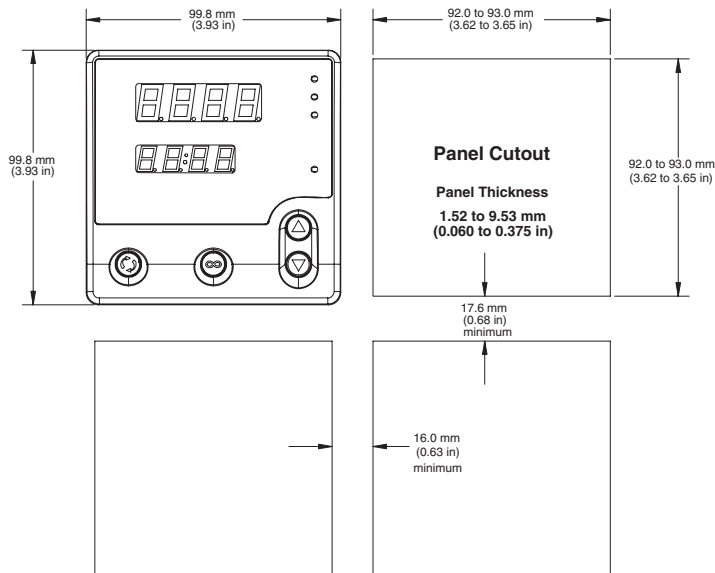

Side

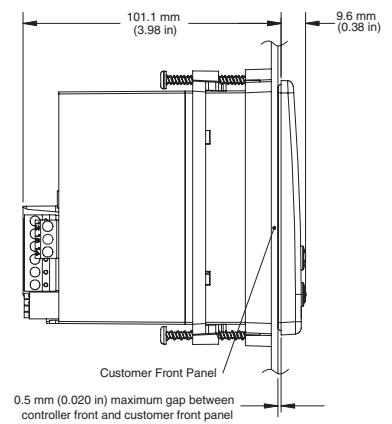

Back

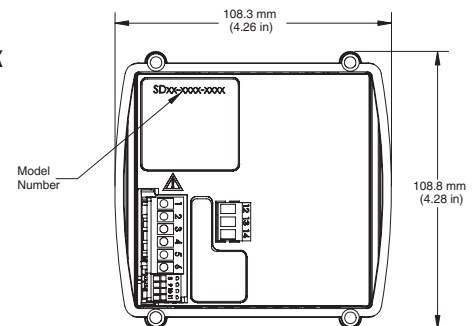

Contact your local Greenlee supplier for the appropriate punch kit and cutout tools required for rapid mounting.



Caution: Follow the installation procedure exactly to guarantee a proper IP65/NEMA 4X seal. Make sure the gasket between the panel and the rim of the case is not twisted and is seated properly. Failure to do so could result in damage to equipment.

Removing the Screw Clamp Connectors

To prevent component damage when removing the screw clamp connector, please follow these steps:

1. Insert a screwdriver in the top of the spring clamp and lift it up as shown.
2. Pull out the sensor connector (pins 8 to 11).
3. Lift up the screw clamp connector.

Note: These directions apply to all Series SD

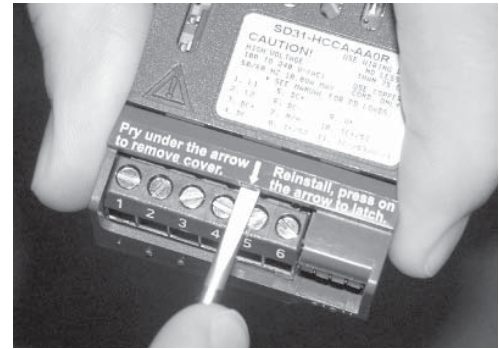

Installation

Installing the 1/32 DIN Series SD Controller

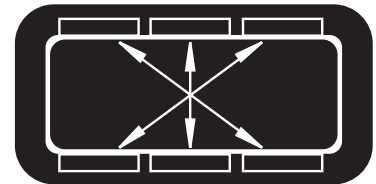
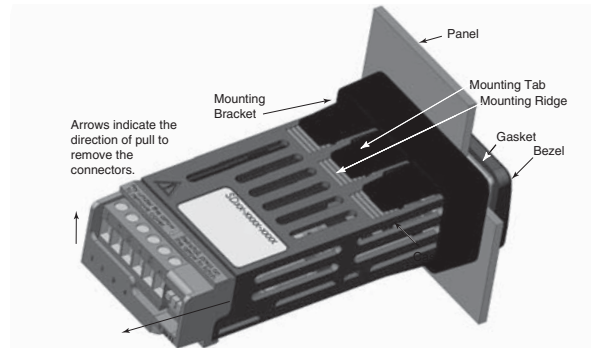

IP65/NEMA 4X Seal Example



Installing and mounting requires access to the back of the panel.

1. Make the panel cutout using the mounting template dimensions in this chapter.
2. Check that the rubber gasket lies in its slot at the back of the bezel. Insert the controller into the panel cutout.
3. While pressing the bezel firmly against the panel, slide the mounting bracket over the back of the controller.
4. If the installation does not require an IP65/NEMA 4X seal, slide the bracket up to the back of the panel enough to eliminate the spacing between the gasket and the panel.

For an IP65/NEMA 4X seal, use your thumb to lock the tabs into place while pressing the controller from side to side. Don't be afraid to apply enough pressure to properly install the controller. If you can move the controller back and forth in the cutout, you do not have a proper seal. The tabs on each side of the bracket have teeth that latch into the ridges.

Each tooth is staggered at a different depth (from the front) so only one of the tabs on each side is ever locked into the ridges at any time. Either the two middle tabs or the two tabs diagonal from each other will be engaged.

5. If the matching tabs are not engaged, you do not have an IP65/NEMA 4X seal. The space between the bezel and panel must be 0 to 0.48 mm (0 to 0.019 in) maximum.

Removing the 1/32 DIN Series SD Controller

1. Remove all the wiring connectors from the back of the controller.
2. Slide a thin, wide tool (putty knife) under all three mounting tabs, on the top and then the bottom, while pushing forward on the back of the case. Be ready to support the controller as it slides out of the panel cutout.

Tools required:
Putty knife or equivalent



Caution: Follow the installation procedure exactly to guarantee a proper IP65/NEMA 4X seal. Make sure the gasket between the panel and the rim of the case is not twisted and is seated properly. Failure to do so could result in damage to equipment.

Note: Be careful not to over-tighten the screws. This may cause the mounting bracket to fail. If the front bezel is touching the front panel, the mounting bracket is too tight.

Installing and mounting requires access to the back of the panel.

Tools required:
one #2 Phillips screwdriver.

Tools required:
one #2 Phillips screwdriver.

Installing the 1/16 DIN Series SD Controller

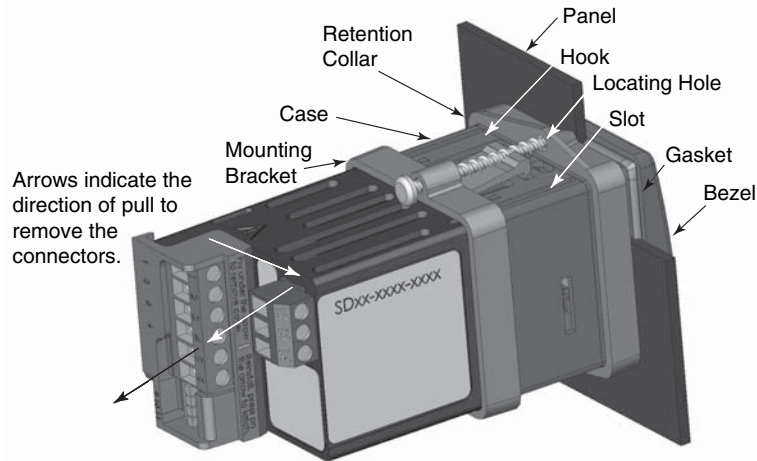

1. Make the panel cutout using the mounting template dimensions in this chapter.
2. Check that the rubber gasket lies in its slot at the back of the bezel. Insert the controller into the panel cutout. Slide the retention collar over the controller, with the locating holes on the top and bottom, facing the back of the controller.
3. Slide the mounting bracket over the back of the controller with the screw tips pointed toward the panel, aligning with the locating holes in the retention collar. Push it gently but firmly over the controller until the hooks snap into the slots at the front.
4. If the installation does not require an IP65/NEMA 4X seal, tighten the two screws with the Phillips screwdriver just enough to eliminate the spacing between the rubber gasket and the panel.

For an IP65/NEMA 4X seal, tighten the two screws until the gap between the bezel and panel surface is 0.6 mm (0.024 in) maximum. Make sure that you cannot move the controller back and forth in the cutout. If you can, you do not have a proper seal. Do not over-tighten. Over-tightening could damage the mounting bracket.

Removing the 1/16 DIN Series SD Controller

1. Remove all the wiring connectors from the back of the controller. While supporting the controller with one hand, use the Phillips screwdriver to unscrew the two screws on the mounting bracket until the tips are flush or past the end of the hooks.
2. Squeeze the two screws together on the mounting bracket to release the hooks from the slots and slide it off the controller. Remove the retention collar and push the controller out of the panel cutout. Be ready to support the controller as it comes through the front panel.



Caution: Follow the installation procedure exactly to guarantee a proper IP65/NEMA 4X seal. Make sure the gasket between the panel and the rim of the case is not twisted and is seated properly. Failure to do so could result in damage to equipment.

Note: Be careful not to over-tighten the screws. This may cause the mounting bracket to fail. If the front bezel is touching the front panel, the mounting bracket is too tight.

Installing and mounting requires access to the back of the panel.

Tools required:
one #2 Phillips screwdriver.

Tools required:
one #2 Phillips screwdriver.

Installing the 1/8 DIN Series SD Controller

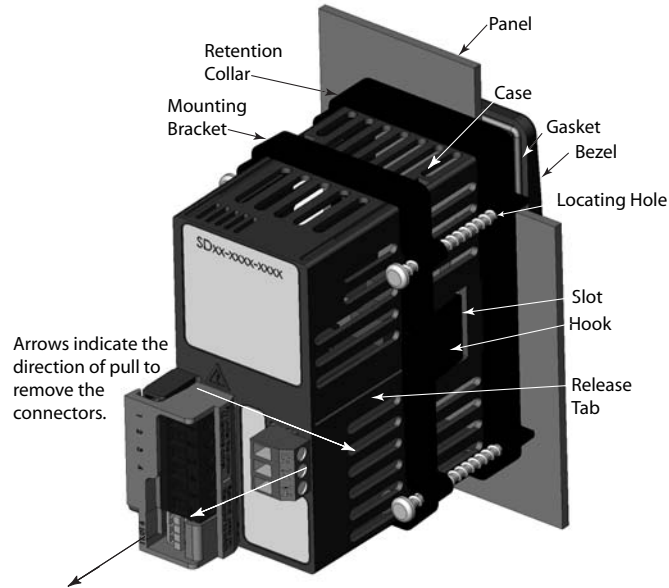

1. Make the panel cutout using the mounting template dimensions in this chapter.
2. Check that the rubber gasket lies in its slot at the back of the bezel. Insert the controller into the panel cutout. Slide the retention collar over the controller, with the locating holes facing the back of the controller.
3. Slide the mounting bracket over the back of the controller with the screw tips pointed toward the panel, aligning with the locating holes in the retention collar. Push it gently but firmly over the controller until the hooks snap into the slots at the front.
4. If the installation does not require an IP65/NEMA 4X seal, tighten the four screws with the Phillips screwdriver just enough to eliminate the spacing between the rubber gasket and the panel.

For an IP65/NEMA 4X seal, tighten the four screws until the gap between the bezel and panel surface is 0.5 mm (0.020 in) maximum. Make sure that you cannot move the controller back and forth in the cutout. If you can, you do not have a proper seal. Do not over-tighten. Over-tightening could damage the mounting bracket.

Removing the 1/8 DIN Series SD Controller

1. Remove all the wiring connectors from the back of the controller. Using the Phillips screwdriver, unscrew the four screws on the mounting bracket until they disengage from the retention collar.
2. Squeeze the release tabs on the long sides of the mounting bracket and slide the mounting bracket off the back of the controller. Remove the retention collar and push the controller out of the panel cutout. Be ready to support the controller as it comes through the front panel.



Caution: Follow the installation procedure exactly to guarantee a proper IP65/NEMA 4X seal. Make sure the gasket between the panel and the rim of the case is not twisted and is seated properly. Failure to do so could result in damage to equipment.

Note: Be careful not to over-tighten the screws. This may cause the mounting bracket to fail. If the front bezel is touching the front panel, the mounting bracket is too tight.

Installing and mounting requires access to the back of the panel.

Tools required:
one #2 Phillips screwdriver.

Tools required:
• one #2 Phillips screwdriver
• one flat-head screwdriver

Installing the 1/4 DIN Series SD Controller

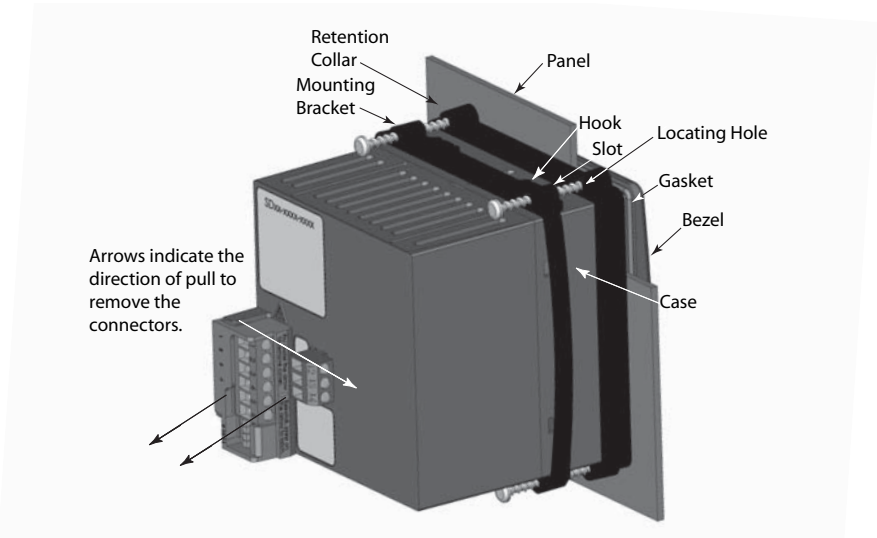

1. Make the panel cutout using the mounting template dimensions in this chapter.
2. Check that the rubber gasket lies in its slot at the back of the bezel. Insert the controller into the panel cutout. Slide the retention collar over the controller, with the locating holes facing the back of the controller.
3. Slide the mounting bracket over the back of the controller with the screw tips pointed toward the panel, aligning with the locating holes in the retention collar. Push it gently but firmly over the controller until the hooks snap into the slots at the front.
4. If the installation does not require an IP65/NEMA 4X seal, tighten the four screws with the Phillips screwdriver just enough to eliminate the spacing between the rubber gasket and the panel.

For an IP65/NEMA 4X seal, tighten the four screws until the gap between the bezel and panel surface is 0.5 mm (0.020 in) maximum. Make sure that you cannot move the controller back and forth in the cutout. If you can, you do not have a proper seal. Do not over-tighten. Over-tightening could damage the mounting bracket.

Removing the 1/4 DIN Series SD Controller

1. Remove all the wiring connectors from the back of the controller. Using the Phillips screwdriver, unscrew the four screws on the mounting bracket (two on top, two on bottom) until they disengage from the retention collar.
2. Slide the tip of a flat screwdriver between the controller and the center top side of the mounting bracket. Rotate the screwdriver 90 degrees, stretching the bracket away from the controller so the hooks on the bracket disengage from the slots. Hold the bracket and press the controller forward slightly to prevent the disengaged hooks from snapping back into the slots.
3. Repeat this operation to disengage the hooks on the bottom side of the mounting bracket.
4. Press with one or two fingers on the lower half of the back of the unit so that the controller slides forward toward the panel. Hold the bracket steady; do not pull back. Be ready to support the controller as it comes through the front panel.

Series SD Family — Back Views in Scale

NOTE: The SD model number determines which diagram applies to your unit.

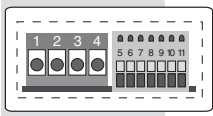

Figure 10a — 1/32 DIN with a Universal Process Output installed for output 1 (S D 3 _ _ F _ _ _ _ _).

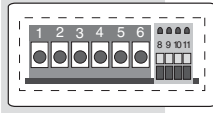

Figure 10b — 1/32 DIN with other than a Universal Process Output installed for output 1 (S D 3 _ _ (C,K or J) _ _ _ _ _).

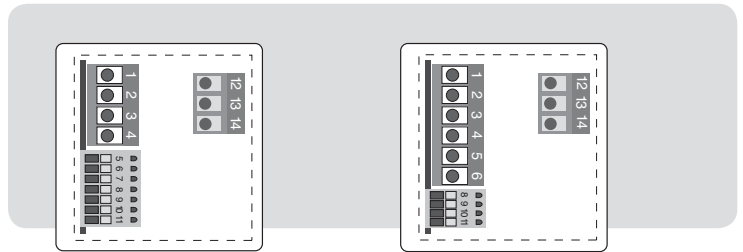

Figure 10c — 1/16 DIN with a Universal Process Output installed for output 1 (S D 6 _ _ F _ _ _ _ _).

Figure 10d — 1/16 DIN with other than a Universal Process Output installed for output 1 (S D 6 _ _ (C,K or J) _ _ _ _ _).

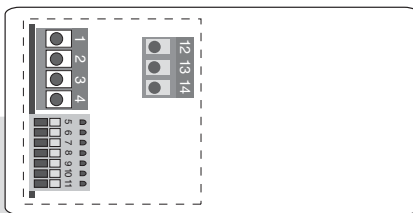

Figure 10e — 1/8 DIN Horizontal with a Universal Process Output installed for output 1 (S D 9 _ _ F _ _ _ _ _).

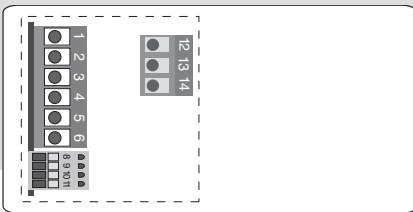

Figure 10f — 1/8 DIN Horizontal with other than a Universal Process Output installed for output 1 (S D 9 _ _ (C,K or J) _ _ _ _ _).

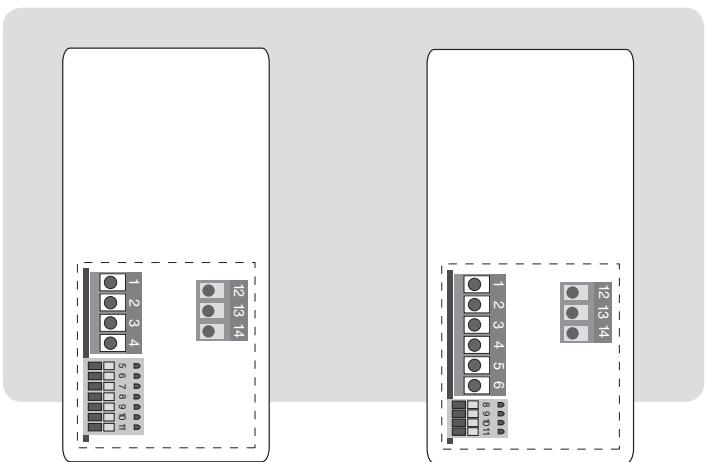

Figure 10g — 1/8 DIN Vertical with a Universal Process Output installed for output 1 (S D 8 _ _ F _ _ _ _ _).

Figure 10h — 1/8 DIN Vertical with other than a Universal Process Output installed for output 1 (S D 8 _ _ (C,K or J) _ _ _ _ _).

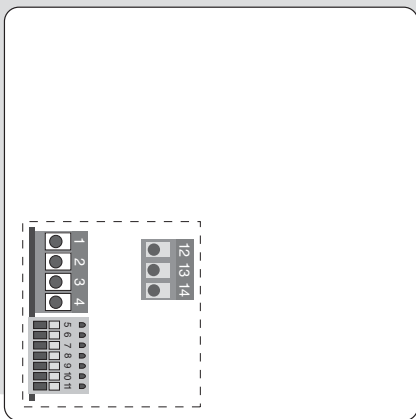

Figure 10i — 1/4 DIN with a Universal Process Output installed for output 1 (S D 4 _ _ F _ _ _ _ _).

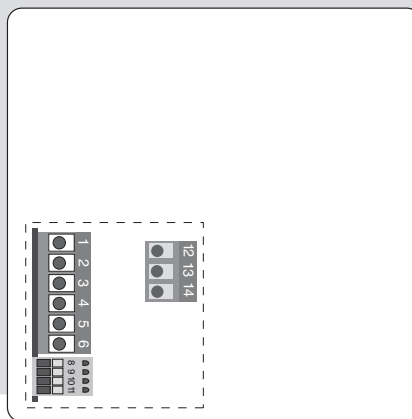

Figure 10j — 1/4 DIN with other than a Universal Process Output installed for output 1 (S D 4 _ _ (C,K or J) _ _ _ _ _).

NOTE:
Terminals 12, 13 and 14 are not installed on controllers without an output 3 (SD _ _ _ _ A- _ _ _ _).



Warning:
Use National Electric (NEC) or other country-specific standard wiring and safety practices when wiring and connecting this controller to a power source and to electrical sensors or peripheral devices. Failure to do so may result in damage to equipment and property, and/or injury or loss of life.

Note: To prevent ground loops, isolation needs to be maintained from input to output when using switched DC or analog process outputs.



WARNING: If high voltage is applied to a low-voltage controller, irreversible damage will occur.

Wiring the Series SD

Isolation Blocks

There are no electrical connections between these blocks.

Sensor Input
Switched DC Outputs
Analog Process Outputs

Power Supply Input

EIA/TIA-485 Communications Input

Relay outputs (mechanical and solid-state) provide isolation through their relay contacts. Each relay output is isolated from the blocks above and is isolated from other relay outputs.

The model number for each output option appears with its wiring diagram. Check the label on the controller and compare your model number to those shown here and to the model number breakdown in the Appendix of this manual.

The connectors on the back of the Series SD are different for different model numbers. Where two different combinations of connectors may appear, we show both in the diagrams.

All outputs, including normally open and normally closed contacts, are referenced to a de-energized state (the controller has power removed).

All wiring and fusing must conform to the National Electric Code and to any locally applicable codes as well.

Figure 11a — High Voltage AC Power Wiring

SD__ - H _____ High

- Nominal voltage: 100 to 240V~ (ac)

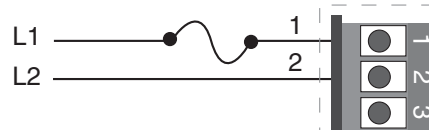
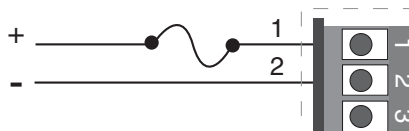

Figure 11b — Low Voltage AC Power Wiring

SD__ - L _____ Low

- Nominal voltage: 24V (ac/dc)
- Class 2 power source required for agency compliance





Warning:
Use National Electric (NEC) or other country-specific standard wiring and safety practices when wiring and connecting this controller to a power source and to electrical sensors or peripheral devices. Failure to do so may result in damage to equipment and property, and/or injury or loss of life.

Spring clamp wiring connector note:

To insert the wire, push the wire into the desired connection number, and it should automatically lock into place. To remove the wire, press and hold the orange release tab with a small screwdriver. Pull the wire out of the connection. Solid or tinned wire recommended.

Note: To prevent ground loops, isolation needs to be maintained from input to output when using switched DC or analog process outputs.



WARNING: Process input may not have sensor break protection. Outputs can remain full on. Check your input settings.

Figure 12a — Thermocouple Input

(all model numbers)

Thermocouples are polarity sensitive. The negative lead (usually red) must be connected to terminal 11.

- Input impedance: >20 MΩ

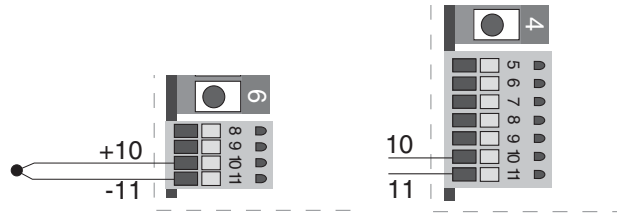

Figure 12b — RTD Input (100 Ω DIN curve 0.00385 Ω/Ω/°C)

(all model numbers)

Terminals 8 and 11 must be shorted for a two-wire RTD. For three-wire RTDs, the S1 lead (usually white) must be connected to terminal 10.

- Nominal excitation current: 390μA

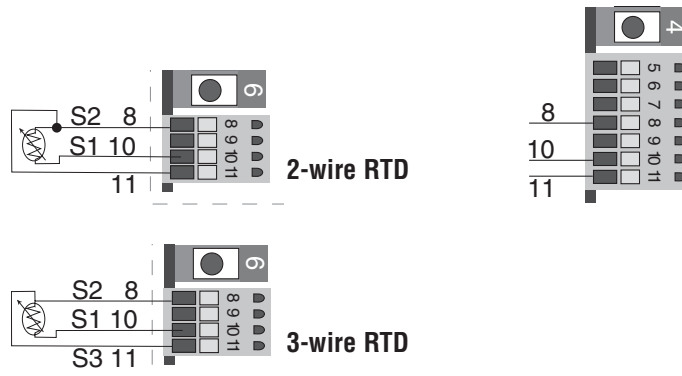

Figure 12c — 0 to 10V_{DC} (dc) Process Input

(all model numbers)

- Input impedance 20 kΩ, dc only.

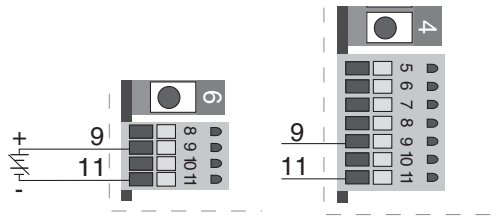
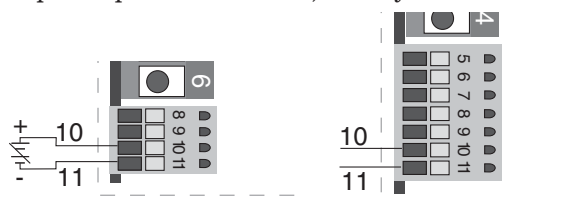

Figure 12d — 0 to 50mV_{DC} (dc) Process Input

(all model numbers)

- Input impedance >20 MΩ, dc only.





WARNING: Process input may not have sensor break protection. Outputs can remain full on. Check your input settings.



Warning: Use National Electric (NEC) or other country-specific standard wiring and safety practices when wiring and connecting this controller to a power source and to electrical sensors or peripheral devices. Failure to do so may result in damage to equipment and property, and/or injury or loss of life.

Quencharc Note: Switching pilot duty inductive loads (relay coils, solenoids, etc.) with the mechanical relay or solid-state relay output requires use of an R.C. suppressor.

Watlow carries the R.C. suppressor Quencharc brand name, which is a trademark of ITW Paktron. Watlow Part No. 0804-0147-0000.

Spring clamp wiring connector note: To insert the wire, push the wire into the desired connection number, and it should automatically lock into place. To remove the wire, press and hold the orange release tab with a small screwdriver. Pull the wire out of the connection. Solid or tinned wire recommended.

Note: To prevent ground loops, isolation needs to be maintained from input to output when using switched DC or analog process outputs.

Figure 13a — 0 to 20 mA Process Input

(all model numbers)

- Input impedance 100 Ω , dc only.
- Controller does not supply power for the current loop.

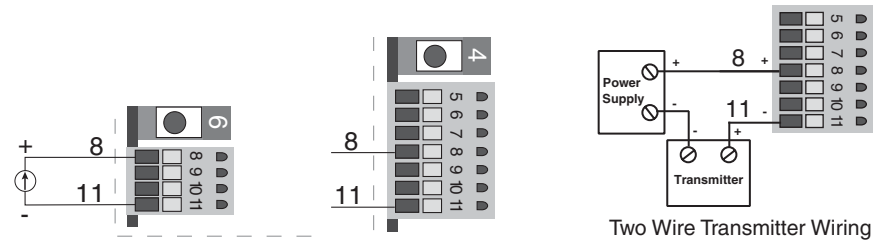

Figure 13b — Output 1 Mechanical Relay

SD _ _ - - **J** _ _ - - - - -

- Form A contact
- 2 A, resistive
- 125 VA pilot duty, 120/240V~ (ac), inductive
- See Quencharc note.
- 240V~ (ac) maximum.
- 30V= (dc) maximum.
- For use with ac or dc.
- Minimum load current 10 mA
- Output does not supply power.

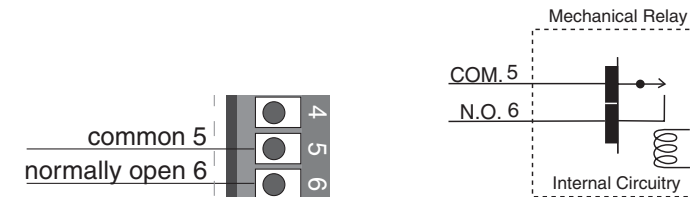
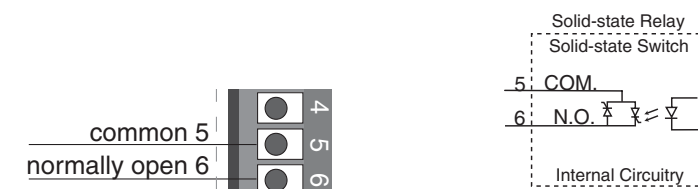

Figure 13c — Output 1 Solid-state Relay

SD _ _ - - **K** _ _ - - - - -

- Form A contact
- 0.5 A maximum, resistive
- 20 VA pilot duty, 120/240V~ (ac), inductive
- See Quencharc note.
- 24 to 240V~ (ac).
- Minimum load current 10 mA
- Maximum leakage current 100 μ A
- Not for use with direct current (dc).
- Output does not supply power.





Warning:

Use National Electric (NEC) or other country-specific standard wiring and safety practices when wiring and connecting this controller to a power source and to electrical sensors or peripheral devices. Failure to do so may result in damage to equipment and property, and/or injury or loss of life.

Quencharc Note:

Switching pilot duty inductive loads (relay coils, solenoids, etc.) with the mechanical relay or solid-state relay output options requires use of an R.C. suppressor.

Watlow carries the R.C. suppressor Quencharc brand name, which is a trademark of ITW Paktron. Watlow Part No. 0804-0147-0000.

Spring clamp wiring connector note:

To insert the wire, push the wire into the desired connection number, and it should automatically lock into place. To remove the wire, press and hold the orange release tab with a small screwdriver. Pull the wire out of the connection. Solid or tinned wire recommended.

Note: To prevent ground loops, isolation needs to be maintained from input to output when using switched DC or analog process outputs.

Figure 14a — Output 1 Switched DC

SD_ _ _ C_ _ _ _ _

- Supply current 30 mA \approx (dc) maximum.
- Supply voltage 6 to 12V \approx (dc).
- Not recommended for switching mechanical relays.
- Output supplies power.

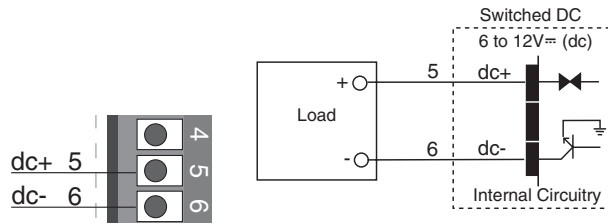

Figure 14b — Output 1 Process

SD_ _ _ F_ _ _ _ _

- Analog output is scalable between 0 to 10V \approx (dc) or 0 to 20 mA \approx (dc).
- Load capability: voltage 1 k Ω minimum; current 800 Ω maximum.
- Output supplies power.
- Cannot use voltage and current output at the same time.

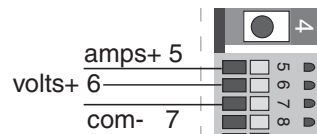
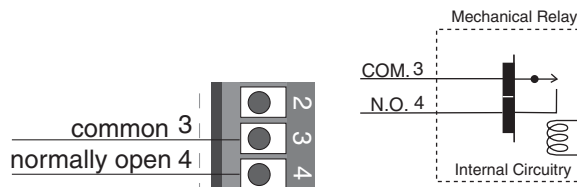

Figure 14c — Output 2 Mechanical Relay

SD_ _ _ J_ _ _ _ _

- Form A contact
- 2 A, resistive
- 125 VA pilot duty, 120/240V \sim (ac), inductive
- See Quencharc note.
- 240V \sim (ac) maximum.
- 30V \approx (dc) maximum.
- For use with ac or dc.
- Minimum load current 10 mA
- Output does not supply power.





Warning:

Use National Electric (NEC) or other country-specific standard wiring and safety practices when wiring and connecting this controller to a power source and to electrical sensors or peripheral devices. Failure to do so may result in damage to equipment and property, and/or injury or loss of life.

Quencharc Note:

Switching pilot duty inductive loads (relay coils, solenoids, etc.) with the mechanical relay or solid-state relay output options requires use of an R.C. suppressor.

Watlow carries the R.C. suppressor Quencharc brand name, which is a trademark of ITW Paktron. Watlow Part No. 0804-0147-0000.

Note: To prevent ground loops, isolation needs to be maintained from input to output when using switched DC or analog process outputs.

Figure 15a — Output 2 Solid-state Relay

SD_ _ - _ _ K _ - _ _ _ _

- Form A contact
- 0.5 A maximum, resistive
- 20 VA pilot duty, 120/240V~ (ac), inductive
- See Quencharc note.
- 24 to 240V~ (ac).
- Minimum load current 10 mA
- Maximum leakage current 100 µA
- Not for use with direct current (dc).
- Output does not supply power.

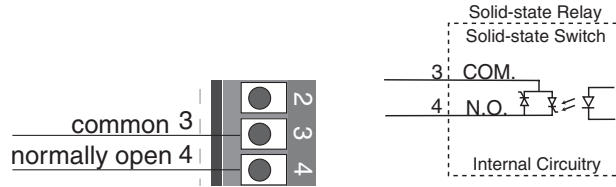

Figure 15b — Output 2 Switched DC

SD_ _ - _ _ C _ - _ _ _ _

- Maximum supply current 30 mA[≡] (dc).
- Supply voltage 6 to 12V[≡] (dc).
- Not recommended for switching mechanical relays.
- Output supplies power.

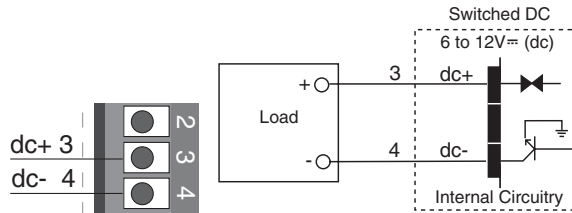
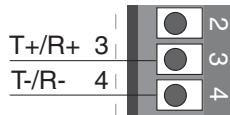

Figure 15c — Output 2 EIA/TIA-485

SD_ _ - _ _ U _ - _ _ _ _

- Isolated [50V[≡] (dc)]
- Half duplex
- For more communications information, see the Features chapter.





Warning:

Use National Electric (NEC) or other country-specific standard wiring and safety practices when wiring and connecting this controller to a power source and to electrical sensors or peripheral devices. Failure to do so may result in damage to equipment and property, and/or injury or loss of life.

Quencharc Note:

Switching pilot duty inductive loads (relay coils, solenoids, etc.) with the mechanical relay or solid-state relay output options requires use of an R.C. suppressor.

Watlow carries the R.C. suppressor Quencharc brand name, which is a trademark of ITW Paktron. Watlow Part No. 0804-0147-0000.

Note: To prevent ground loops, isolation needs to be maintained from input to output when using switched DC or analog process outputs.

Figure 16a — Output 3 Mechanical Relay

SD_ _ - _ _ _ E - _ _ _ _

- Form A contact
- 5 A, resistive
- 125 VA pilot duty, 120/240V~ (ac), inductive
- See Quencharc note.
- 240V~ (ac) maximum.
- 30V= (dc) maximum.
- For use with ac or dc.
- Minimum load current 10 mA
- Output does not supply power.

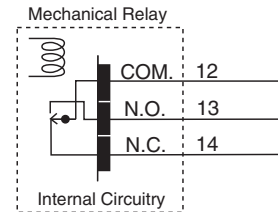
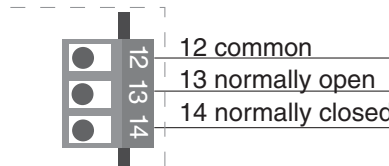

Figure 16b — Output 3 Solid-state Relay

SD_ _ - _ _ _ K - _ _ _ _

- Form A contact
- 0.5 A maximum, resistive
- 20 VA pilot duty, 120/240V~ (ac), inductive
- See Quencharc note.
- 24 to 240V~ (ac).
- Minimum load current 10 mA
- Maximum leakage current 100 µA
- Not for use with direct current (dc).
- Output does not supply power.

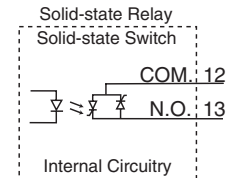
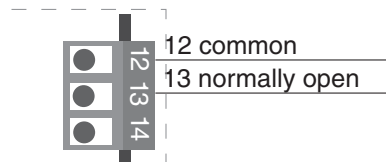
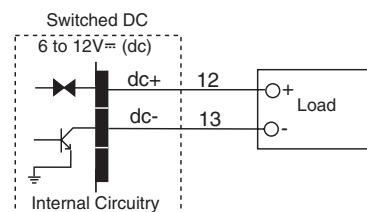
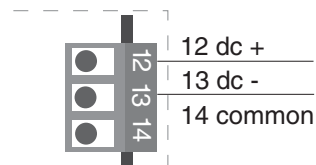

Figure 16c — Output 3 Switched DC

SD_ _ - _ _ _ C - _ _ _ _

- Maximum supply current 30 mA= (dc).
- Supply voltage 6 to 12V= (dc).
- Not for switching mechanical relays.
- Output supplies power.





Warning:
Use National Electric (NEC) or other country-specific standard wiring and safety practices when wiring and connecting this controller to a power source and to electrical sensors or peripheral devices. Failure to do so may result in damage to equipment and property, and/or injury or loss of life.

Quencharc Note:
Switching pilot duty inductive loads (relay coils, solenoids, etc.) with the mechanical relay or solid-state relay output options requires use of an R.C. suppressor.

Watlow carries the R.C. suppressor Quencharc brand name, which is a trademark of ITW Paktron. Watlow Part No. 0804-0147-0000.

Note: To prevent ground loops, isolation needs to be maintained from input to output when using switched DC or analog process outputs.

Figure 17a — Output 3 Open Collector

SD_ _ - _ _ _ C - _ _ _ _

- Maximum current sink 250 mA_{rms} (dc).
- Maximum supply voltage 42V_{rms} (dc).
- For inductive loads, see Quencharc note.
- Output does not supply power.

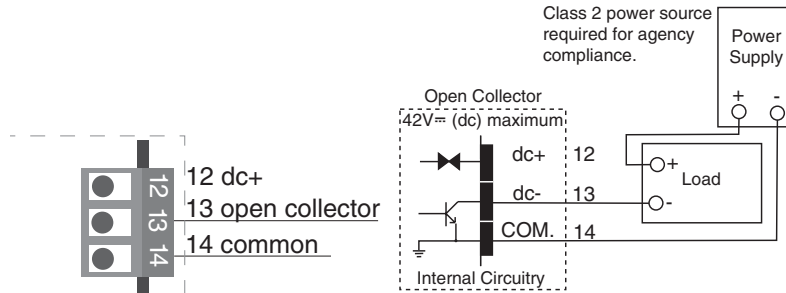
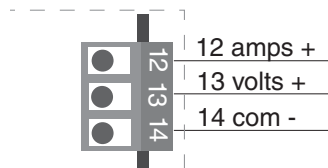

Figure 17b — Output 3 Process

SD_ _ - _ _ _ F - _ _ _ _

- Analog output scalable from 0 to 10V_{rms} (dc) or 0 to 20 mA_{rms} (dc).
- Load capability: voltage, 1 kΩ minimum; current, 800 Ω maximum.
- Output supplies power.
- Cannot use voltage and current output at the same time.



Selecting an EIA/TIA-232 to EIA/TIA-485 Converter

When choosing an EIA/TIA 232 to 485 converter, look for one with the following features:

Two-wire capability

EIA/TIA-485 can be implemented as a two-wire system or a four-wire system. Most Watlow controllers, including the Series SD, use two-wire communications when working with EIA/TIA-485. The converter selected must have a two-wire mode. Some converters can only be used in a four-wire mode.

Automatic Send Data control

In a two-wire system, both the transmitted signals and the received signals travel over the same pair of wires, so the converter must have a method of changing from the transmit mode to the receive mode. Some converters require the toggling of a control line (usually the RTS line) to perform this transition, while others use an automatic timing circuit. The toggling method is dependent on the PC software to toggle the control line and the PC's operating system to make that transition happen in a timely manner. Because of these dependencies, the best choice for a converter is one with automatic control.

Isolation

Converters are available with or without input-to-output isolation. An isolated converter is not a requirement when used with the Series SD, but it is recommended to avoid ground loops. Isolation could be a consideration when the Series SD will be used on a network with other devices that may require isolation.

Power Supply

Many converters can be powered up either through the signals of a serial port or through an external power supply. Because some computers, such as laptops, do not always provide enough power to supply the converter, we recommend using an external power supply with specifications as recommended by the converter manufacturer. Isolated converters may require two supplies.

Biasing and termination

If the system does not work properly, it may need termination resistors at each end of the network. A typical installation would require a 120-ohm resistor across the transmit/receive terminals (3 and 4) of the last controller in the network and the converter box. Pull-up and pull-down resistors may be needed at the converter to maintain the correct voltage during the idle state. The pull-up resistor is connected between the positive of the DC supply and the T+/R+ terminal. The pull-down resistor is connected between the negative of the DC supply and the T-/R- terminal.

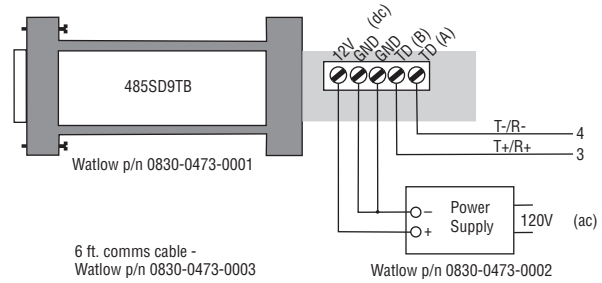

Figure 18a — B&B Converters
Isolated Converter - 4850I9TB
Non-Isolated Converter - 485SD9TB
B&B Electronics Manufacturing Company,
(815) 433-5100, <http://www.bb-elec.com/>

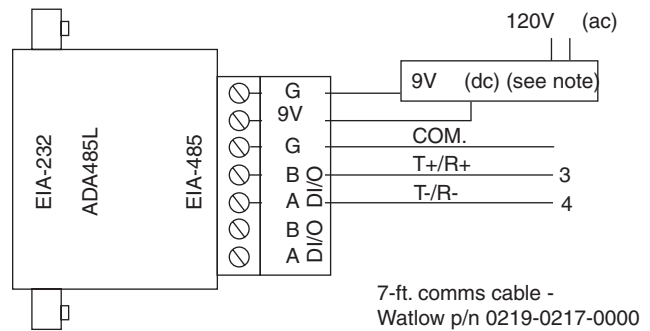

Figure 18b — CMC Non-Isolated Converter - ADA485L
CMC Connecticut Micro-Computer, Inc.,
1-800-426-2872, <http://www.2cmc.com/>

NOTE:

The CMC converter requires an external power supply when used with a laptop computer.

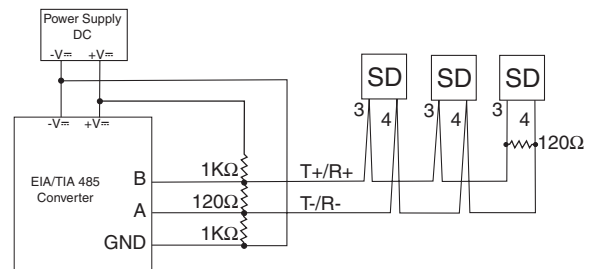

Figure 18c — Wiring bias and termination resistors.
Controllers must be wired in a daisy chain configuration.
Add a 120Ω termination resistor on the last controller.

Ethernet Gateway

The EM00-GATE-0000 is a bridge that allows up to 32 Watlow controllers to be directly connected to an Ethernet network.

The gateway provides a bridge for Modbus messages between the Ethernet bus and EIA-485 or EIA-232 links. The Gateway supports full product configuration monitoring and configuration of runtime parameters via MODBUS TCP over TCP/IP using a software package such as Watlow's WATVIEW™.

The Series SD can be configured using WATVIEW with or without the EM Gateway.

For more information, go to www.watlow.com and search on EM Gateway.

Note: The 32 controller maximum is a functional limitation of the Ethernet Gateway.

Note: The EM Gateway does not currently support the Series SD profiling version.

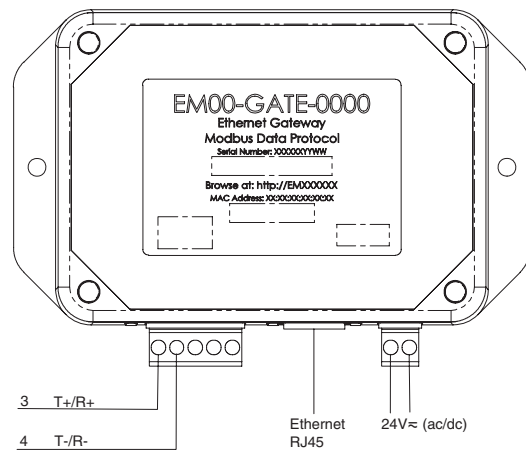

Figure 19a — Connecting to the Watlow EM Gateway (Ethernet to EIA/TIA-485 Serial Modbus connection). Controllers must be wired in a daisy chain configuration.

Note: UL Approved, Class 2, power supply required as EM Gateway power source: 24V~ (dc), part 0830-0474-000.

3

Chapter 3: Keys and Displays

1/32 DIN



1/16 DIN



1/8 DIN Horizontal

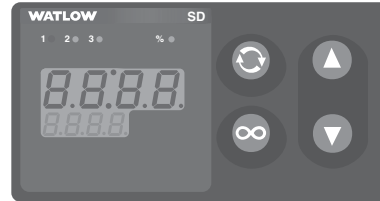

1/8 DIN Vertical



1/4 DIN

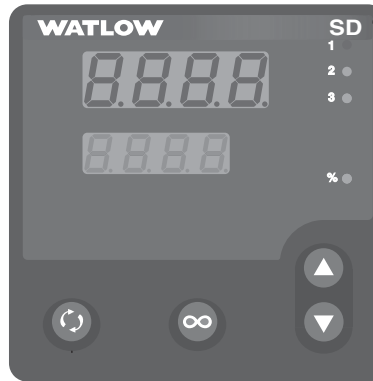

Upper Display (Left Display on 1/32 DIN): Indicates the process in the Home Page, or the value of the parameter in the lower display in other pages.

Lower Display (Right Display on 1/32 DIN): Indicates the set point or output power value during operation, or the parameter whose value appears in the upper display.

1/32 DIN



Advance Key

Advances the lower or right display through parameter prompts.

Toggle between File and Step in Pre-Run menu (profiling version only).



Infinity Key

Returns to the Home Page.

Clears latching alarms.

Start, hold or resume a profile (profiling version only).



Up and Down Keys

In the Home Page, adjusts the set point in the lower or right display. In other pages, changes the upper display to a higher or lower value.



Active Output Indicator Lights

Lit when the corresponding controller output or alarm is on.



Auto-Manual Control Indicator Light

(static set point version only)

On: Manual Mode (open loop control)

Off: Auto Mode (closed loop control)



Profile Status Indicator Light

(profiling version only)

On: Running a profile

Off: Not running a profile

Flashing: Pre-Run menu

Note: After 60 seconds with no key presses, the controller reverts to the Home Page.





Home Page Overview

The Home Page is the default display of the Series SD controller. The process value is usually shown in the upper display. Press Infinity Key  to return to Home Page from any page or parameter.

Note: See the Profiling chapter for more profiling information.





Automatic Mode (static set point version) % **

The % indicator light is off.

 Actual temperature
 Temperature set point (Use Up  or Down  keys to raise or lower the set point.)





Manual Mode (static set point version) % **

The % indicator light is on.

 Actual temperature
 Output power setting (Use Up  or Down  keys to raise or lower the percent power set point.)

Manual Mode (profiling version) ***

Note: A profile can be started from Manual Mode. See the Profiling chapter.





 Actual temperature
 Output power setting (Use Up  or Down  keys to raise or lower the percent power set point.)

Error condition ** ***

The % indicator light is on** or the profile indicator light is off***. If the controller was in Auto mode it will switch to Manual mode when it detects an input error. If a profile is running, it switches to the Hold mode. The profile can be resumed, once the error condition is cleared.***

 Dashed lines
 Error message









Alarm Message

  Process value
 

If alarm message is enabled for an output, the alarm message alternates with set point (auto) or power setting (manual). The corresponding output indicator light is on.

During Ramp to Set Point**

The lower display alternates between the current set point achieved in the ramp and the target set point.

    Actual temperature
   

Current set point prompt Current set point value Ramp target prompts Ramp target set point value





**Static set point version only

***Profiling version only

Adjusting the temperature set point

Adjust the temperature set point in the Home Page. It is not necessary to enter any other page. The temperature set point appears in the lower display and only appears when the controller is in the automatic mode.

To adjust the set point:

1. Ensure the controller is in the automatic mode and that you are on the Home Page. If you are on any other page, press the Infinity Key .
2. The temperature set point is displayed in the lower display window. Press the Up Key  to increase the temperature. Press the Down Key  to decrease the temperature. The set point cannot be set manually while a profile is running.
3. The controller will automatically begin using the new set point after three seconds. Or press the Infinity Key  to immediately use the new value.

Note: The  parameter can lock the ability to adjust the set point. If you are unable to adjust the set point, check  setting on the Setup Page.

Note: While a profile is running, the set point cannot be manually adjusted.

Note: To stop the Series SD PID controller or PID profiling controller from controlling to a set point, press the Down Key while the set point value is equal to the SP.Lo setting.  will be displayed in the lower display and the controller will no longer attempt to maintain a set point.







Caution:

The controller is in the manual mode when the percent indicator is lit** or  appears in the most significant digit of the lower display***. If the controller is in the manual mode, the number displayed in the lower display is the manual output power level. Setting this value can force an output to stay on, regardless of the temperature reading. Always ensure you are in the automatic mode when adjusting the temperature set point.

Operations Page Overview

The Operations Page contains parameters accessed during normal day-to-day operation. The Series SD provides a patented user-definable menu system, allowing the user to customize the Operations Page contents. To go to the Operations Page, press the Advance Key  once from the Home Page.





























- Press the Advance Key  to move through the parameter prompts. At the end of the Operations Page parameters, press the Infinity Key  to return to the Home Page.
- Press the Up  or Down  keys to change the parameter value.
- Press the Infinity Key  at any time to return to the Home Page.

Note: The Operations Page is not accessible while a profile is running.***

Operations Page (typical defaults)

SD_(C or R) - _ _ _ _ - _ _ _ _



	Power Heat
	Auto-Manual**
	Guaranteed Soak Deviation Value***
	Autotune
	Calibration Offset
	Heat Control Method
	Proportional Band Heat
	Reset Heat OR
	Integral Heat
	Rate Heat OR
	Derivative Heat
	Heat Hysteresis
	Cool Control Method
	Proportional Band Cool
	Reset Cool OR
	Integral Cool
	Rate Cool OR
	Derivative Cool
	Cool Hysteresis
	Alarm 1 High
	Alarm 1 Low
	Alarm 2 High
	Alarm 2 Low
	Alarm 3 High
	Alarm 3 Low
	Event Output 1***
	Event Output 2***
	Event Output 3***





















*** Profiling version only (SD_R- _ _ _ _ - _ _ _ _)

Operations Page with TRU-TUNE+™

SD_E- _ _ _ _ - _ _ _ _

(typical defaults)



	Power Heat
	Auto-Manual**
	Autotune
	TRU-TUNE+™ Enable
	Calibration Offset
	Heat Control Method
	Proportional Band Heat
	Heat Hysteresis
	Cool Control Method
	Proportional Band Cool
	Cool Hysteresis
	Integral
	Derivative
	Alarm 1 High
	Alarm 1 Low
	Alarm 2 High
	Alarm 2 Low
	Alarm 3 High
	Alarm 3 Low
	None

Note: Hardware configuration and programming selections determine what parameters appear in the Operations Page. A maximum of 20 or 23 * parameters can be defined to appear on the Operations Page. The Programming Page settings determine what appears on the Operations Page.**



Caution:

The controller is in the manual mode when the percent indicator is lit or  appears in the most significant digit of the lower display***. If the controller is in the manual mode, the number displayed in the lower display is the manual output power level. Setting this value can force an output to stay on, regardless of the temperature reading. Always ensure you are in the automatic mode when adjusting the temperature set point.

Setup Page Overview

SET
PAGE

The Setup Page contains parameters that define basic controller functions. Go to the Setup Page for initial configuration or if your application requirements change. Be sure to program the Setup Page first!

Always press the Infinity Key ∞ to return to the Home Page.

You must start from the Home Page.

To go to the Setup Page, press both the Up \uparrow and Down \downarrow keys for about three seconds.

- Press the Advance Key \rightarrow to move through the parameter prompts.
- Press the Up \uparrow or Down \downarrow keys to change the parameter value.
- Press the Infinity Key ∞ at any time to return to the Home Page.

Note: Hardware configuration and programming selections determine what parameters appear on the Setup Page.

Note: The Setup Page is not accessible while a profile is running.***

∞ Setup Page

- SEn Sensor Type
- Lin Thermocouple Linearization
- $C-F$ Temperature Units
- $SdEL$ Temperature Decimal Places
- $PdEL$ Process Decimal Places
- $ISEn$ InfoSense
- $ISP1$ InfoSense Point 1
- $ISP2$ InfoSense Point 2
- $ISP3$ InfoSense Point 3
- $ISP4$ InfoSense Point 4
- $ScLo$ Process Scale Low
- $ScHi$ Process Scale High
- $PiLE$ Process Input Low Error
- $PiHE$ Process Input High Error
- $r9Lo$ Units Scale Low
- $r9Hi$ Units Scale High
- $SPLo$ Set Point Low Limit
- $SPHi$ Set Point High Limit
- $FtEr$ Input Filter
- $FLtr$ Filter Value
- $Of1$ Output 1 Function
- $Ctr1$ Control Method 1
- $FtB1$ Fixed Time Base 1
- $PL1$ Power Limit 1
- $P5L1$ Output Power Scale Low 1
- $P5H1$ Output Power Scale High 1
- $nLF1$ Output Non-linear Function 1
- $AO1U$ Analog Output 1 Units
- $O1Lo$ Analog Output 1 Scale Low
- $O1Hi$ Analog Output 1 Scale High
- $r1So$ Output 1 Retransmit Source
- $r1Lo$ Output 1 Retransmit Low Scale
- $r1Hi$ Output 1 Retransmit High Scale
- $r1CO$ Output 1 Retransmit Offset

Setup Page (continued)

- $Of2$ Output 2 Function
- $Ctr2$ Control Method 2
- $FtB2$ Fixed Time Base 2
- $PL2$ Power Limit 2
- $P5L2$ Output Power Scale Low 2
- $P5H2$ Output Power Scale High 2
- $nLF2$ Output Non-linear Function 2
- $Of3$ Output 3 Function
- $Ctr3$ Control Method 3
- $FtB3$ Fixed Time Base 3
- $PL3$ Power Limit 3
- $P5L3$ Output Power Scale Low 3
- $P5H3$ Output Power Scale High 3
- $nLF3$ Output Non-linear Function 3
- $AO3U$ Analog Output 3 Units
- $O3Lo$ Analog Output 3 Low Scale
- $O3Hi$ Analog Output 3 High Scale
- $r3So$ Output 3 Retransmit Source
- $r3Lo$ Output 3 Retransmit Low Scale
- $r3Hi$ Output 3 Retransmit High Scale
- $r3CO$ Output 3 Retransmit Offset
- $hYS1$ Alarm 1 Hysteresis
- $L9c1$ Alarm 1 Logic
- $LAt1$ Alarm 1 Latching
- $Sil1$ Alarm 1 Silencing
- $dSP1$ Alarm 1 Message
- $hYS2$ Alarm 2 Hysteresis
- $L9c2$ Alarm 2 Logic
- $LAt2$ Alarm 2 Latching
- $Sil2$ Alarm 2 Silencing
- $dSP2$ Alarm 2 Message
- $hYS3$ Alarm 3 Hysteresis
- $L9c3$ Alarm 3 Logic
- $LAt3$ Alarm 3 Latching
- $Sil3$ Alarm 3 Silencing
- $dSP3$ Alarm 3 Message
- $ACLF$ AC Line Frequency
- $UnIt$ Units of Measurement
- $IErr$ Input Error Latching
- $FAIL$ Input Error Failure Mode
- $P7An$ Input Error Power
- dSP Active Displays
- rP Ramping Mode**
- $rPSc$ Ramp Scale**
- $rPrE$ Ramp Rate**
- $PtYP$ Profile Type***
- $PStE$ Profile Start***
- $9SdE$ Guaranteed Soak Deviation Enable****
- $9Sd$ Guaranteed Soak Deviation Value****
- $Addr$ Modbus Device Address
- $bAud$ Baud Rate
- $tTun$ TRU-TUNE+™ Enable****
- $AgRS$ Autotune Aggressiveness
- $tBnd$ Tune Band****
- tGn Tune Gain****
- LOC Lockout

** Static set point version only

*** Profiling version only

**** TRU-TUNE+™ version only

Programming Page Overview

Prog
Page

The Programming Page determines what parameters the user wants to appear on the Operations Page. Select a parameter for any of the 20 (23 for the profiling version***) Programming Page locations, P1 to P20 (P23***). These now appear on the Operations Page. All 20 (23***) locations have parameters selected as defaults.

To go to the Programming Page, hold down the Infinity key ∞ , then press the Advance Key \rightarrow , and hold both down for about six seconds.

- Press the Advance Key \rightarrow to move through the parameter prompts.
- Press the Up \uparrow or Down \downarrow keys to change the parameter value.
- Press the Infinity Key ∞ at any time to return to the Home Page.

Note: The hardware configuration and programming selections will also determine what parameters appear on the Operations Page. A Programming Page selection will not appear on the Operations Page if the parameter is not active.

Note: The Programming Page is not accessible while a profile is running. ***

Programming Page

P1	Parameter Location 1 (48)
P2	Parameter Location 2 (49)
P3	Parameter Location 3 (50)
P4	Parameter Location 4 (51)
P5	Parameter Location 5 (52)
P6	Parameter Location 6 (53)
P7	Parameter Location 7 (54)
P8	Parameter Location 8 (55)
P9	Parameter Location 9 (56)
P10	Parameter Location 10 (57)
P11	Parameter Location 11 (58)
P12	Parameter Location 12 (59)
P13	Parameter Location 13 (60)
P14	Parameter Location 14 (61)
P15	Parameter Location 15 (62)
P16	Parameter Location 16 (63)
P17	Parameter Location 17 (64)
P18	Parameter Location 18 (65)
P19	Parameter Location 19 (66)
P20	Parameter Location 20 (67)
P21	Parameter Location 21 (68)***
P22	Parameter Location 22 (69)***
P23	Parameter Location 23 (47)***

*** Profiling version only

Factory Page Overview

Fact
Page

The Factory Page contains information on diagnostics, calibration and restore-parameter functions.

To go to the Factory Page, press both the Up \uparrow and Down \downarrow keys for about six seconds from the Home Page.

- Press the Advance Key \rightarrow to move through the parameter prompts.
- Press the Up \uparrow or Down \downarrow keys to change the parameter value of Read/Write (R/W) parameters.
- Press the Infinity Key ∞ at any time to return to the Home Page.

Note: Hardware configuration and programming selections determine what parameters appear on the Factory Page.

Note: The Factory Page is not accessible while a profile is running. ***

Factory Page

Amb	Ambient Temperature
ARn	Minimum Recorded Ambient Temperature
ARm	Maximum Recorded Ambient Temperature
dSPL	Display Intensity
ROE1	Output 1 Process Value
ROE3	Output 3 Process Value
rESE	Restore Factory Calibration
USrr	Restore User Settings
USrS	Save User Settings
PrFr	Restore Profile Settings***
PrFS	Save Profile Settings***
dFLT	Default Parameters
OEY1	Output 1 Type
OEY2	Output 2 Type
OEY3	Output 3 Type
SId	Software ID
SUEr	Software Version
SbLd	Software Build Number
PuJr	Power Type
Sn-	Serial Number 1 (first four digits)
Sn	Serial Number 2 (last four digits)
tc50	Thermocouple, 50mV
tc00	Thermocouple, 0mV
tc32	Thermocouple, 32°F
r.15	RTD, 15 ohm
r.380	RTD, 380 ohm
U.1	Input Calibrate, 1.0 Volt
U.9	Input Calibrate, 9.0 Volt
A.4	Input Calibrate, 4.0 mA
A.16	Input Calibrate, 16.0 mA
O.1.1u	Output 1 Calibrate, 1.0 Volt
O.1.9u	Output 1 Calibrate, 9.0 Volt
O.1.4A	Output 1 Calibrate, 4.0 mA
O.1.16	Output 1 Calibrate, 16.0 mA
O.3.1u	Output 3 Calibrate, 1.0 Volt
O.3.9u	Output 3 Calibrate, 9.0 Volt
O.3.4A	Output 3 Calibrate, 4.0 mA
O.3.16	Output 3 Calibrate, 16.0 mA

Calibration information for the Series SD controllers is available in pdf format. Go to www.watlow.com / Literature / Product User Manuals and search on *Series SD Calibration Manual*.

4

Chapter 4: Home Page

Press the Infinity Key ∞ at any time to go to the Home Page.

Depending upon the controller's status, you will see some combination of the parameters listed below. Normally, you will see the Process Value in the upper display and the Set Point in the lower display. See Home Page Overview in the Keys and Displays chapter.

After 60 seconds with no key presses, the controller reverts to the Home Page.

Display	Parameter Name Description	Settings	Range (Integer values for Modbus in parenthesis.)	Default	Modbus* (less 40,001 offset) Read/Write	Appears if:
Measured Value	Process Value Displays the current process value in the upper (left in 1/32 DIN) display.		-1999 to 9999 degrees or units (-1999000 to 9999000)	NA	*20, 21 R	There is no input error and [ErrE] is set to [OFF] or [Cont] .
Set Value	Closed Loop Set Point Show the current closed loop control set point in the lower (right in 1/32 DIN) display.		Set Point Low Limit [SPLo] to Set Point High Limit [SPh] [OFF] Stop controlling to SP (-20000001)	75	*27, 28 R/W	Control mode is [Auto] and there is no input error.
Measured Value	Filtered Process Value Displays the current filtered process value in the upper (left in 1/32 DIN) display.		-1999 to 9999 degrees or units (-1999000 to 9999000)	NA	*22, 23 R	There is no input error and [ErrE] is set to [d.SP] or [both] .
Set Value	Open Loop Output Power Show the current open loop (manual) control set point in the lower (right in 1/32 DIN) display. The % indicator light is on when the controller is in open loop (manual control).		-100.0 to 0.0% if any output is set to cool; 0.0 to 100.0% if any output is set to heat (-10000 to 0000, 0000 to 10000. Two decimal places implied for Modbus.)	0.0%	26 R/W	Control mode is [Man] . If there is no input error and [ErrE] is set to [OFF] or [Cont] .
[rP]	Current Ramp Set Point** The current working control set point for the ramp that is in process appears in the lower (right in 1/32 DIN) display after this prompt appears.		-1999 to 9999 (-1999000 to 9999000)	NA	*254, 255 R	Static set point version only and ramp to set point active. (SD_C - ____ - ____)
[rPt9]	Ramp Target Set Point The target set point for the ramp that is in process appears in the lower (right in 1/32 DIN) display after this prompt appears.		Set Point Low Limit [SPLo] to Set Point High Limit [SPh]	NA	Same as closed loop set point.	Static set point version only and ramp to set point active. (SD_C - ____ - ____)
[ErrIn]	Input Error Indicate an input error state.		None (0) [- - -] Error (1)	NA	24 R	There is an analog input error
[AlLo]	Alarm Low 1 Status Indicate a low alarm at output 1.		None (0) Alarm (1)	NA	29 R	There is an Alarm 1 low side alarm.
[AlH]	Alarm High 1 Status Indicate a high alarm at output 1.		None (0) Alarm (1)	NA	30 R	There is an Alarm 1 high side alarm
[Al2Lo]	Alarm Low 2 Status Indicate a low alarm at output 2.		None (0) Alarm (1)	NA	31 R	There is an Alarm 2 low side alarm.
[Al2H]	Alarm High 2 Status Indicate a high alarm at output 2.		None (0) Alarm (1)	NA	32 R	There is an Alarm 2 high side alarm
[Al3Lo]	Alarm Low 3 Status Indicate a low alarm at output 3.		None (0) Alarm (1)	NA	33 R	There is an Alarm 3 low side alarm
[Al3H]	Alarm High 3 Status Indicate a high alarm at output 3.		None (0) Alarm (1)	NA	34 R	There is an Alarm 3 high side alarm.

Note: Some values will be rounded off to fit in the four-character display. Full values can be read with Modbus. All temperature parameters are in °F through Modbus.





* Low register numbers contain the two higher bytes; high register numbers contain the two lower bytes of the four-byte integer. Decimal precision is implied at three decimal places unless otherwise noted.

** Static set point version only (SD_C-____ - ____).

5

Chapter 5: Setup Page

To go to the Setup Page, press both the Up  and Down  keys for three seconds from the Home Page. **SEn** will appear in the upper display and **PAGE** will appear in the lower display.

- Press the Advance Key  to move through the parameter prompts.
- Press the Up  or Down  key to change the parameter value.
- Press the Infinity Key  at any time to return to the Home Page display.

Display	Parameter Name Description	Settings	Range (Integer values for Modbus in parenthesis.)	Default	Modbus* (less 40,001 offset) Read/Write	Appears if:
SEn [SEn]	Sensor Type Set the analog sensor type.		tc (0) rtd (1) PTA (2) volt (3) PTU (5)	tc (0)	70 R/W	Always active.
Lin [Lin]	Thermocouple Linearization Set the analog input thermocouple linearization.		J J (0) D D (6) H K (1) PTI PT11 (7) T T (2) R R (8) E E (3) S S (9) N N (4) B B (10) C C (5)	tc J (0)	71 R/W	SEn is set to tc .
C-F [C-F]	Temperature Units Set the temperature units for thermocouple and RTD inputs.		F Fahrenheit (0) C Celsius (1)	F (0)	40 R/W	SEn is set to tc or rtd .
	Temperature Units via Serial Comms		Fahrenheit (0) Celsius (1)	(0)	18 R/W	SEn is set to tc or rtd .
S.dEC [S.dEC]	Temperature Decimal Places Set the decimal places for the displayed input value for thermocouple and RTD types.		0 (0) 00 (1)	0 (0)	41 R/W	SEn is set to tc or rtd .
P.dEC [P.dEC]	Process Decimal Places Set the decimal places for the displayed input value for process types.		0 (0) 00 (1) 000 (2) 0000 (3)	0 (0)	42 R/W	SEn is set to PTA , volt or PTU .
ISEn [IS.En]	INFOSENSE™ Enable the sensor feature, which synchronizes the controller with a Watlow sensor.		no (0) YES (1)	no (0)	91 R/W	Always active.
IS.P1 [IS.P1]	INFOSENSE™ 1 Set sensor point 1 code.		0 to 999 (0 to 999)	500	92 R/W	ISEn is set to YES .
IS.P2 [IS.P2]	INFOSENSE™ 2 Set sensor point 2 code.		0 to 999 (0 to 999)	500	93 R/W	ISEn is set to YES .
IS.P3 [IS.P3]	INFOSENSE™ 3 Set sensor point 3 code.		0 to 999 (0 to 999)	500	94 R/W	ISEn is set to YES .
IS.P4 [IS.P4]	INFOSENSE™ 4 Set sensor point 4 code.		0 to 999 (0 to 999)	500	95 R/W	ISEn is set to YES .

Note: Some values will be rounded off to fit in the four-character display. Full values can be read with Modbus. All temperature parameters through Modbus are in °F, by default. Writing to register 18 will toggle between °F and °C.

* Low register numbers contain the two higher bytes; high register numbers contain the two lower bytes of the four-byte integer. Decimal precision is implied at three decimal places unless otherwise noted.

** Static set point version only (SD_C-____-____).

*** Profiling version only (SD_R-____-____).

Display	Parameter Name Description	Settings	Range (Integer values for Modbus in parenthesis.)	Default	Modbus* (less 40,001 offset) Read/Write	Appears if:
Sc.Lo [Sc.Lo]	Process Scale Low Set the low scale for process inputs.		0.00 to 20.00 mA: if SEn is set to r7A (0000 to 20000) 0.00 to 10.00 V: if SEn is set to u0LE (0000 to 10000) 0.00 to 50.00 mV: if SEn is set to r7u (0000 to 50000)	4.00 mA 0.00 V 0.00 mV	*73, 74 R/W (mA) *77, 78 R/W (V) *331, 332 R/W (mV)	SEn is set to r7A , SEn is set to u0LE , SEn is set to r7u .
Sc.hi [Sc.hi]	Process Scale High Set the high scale for process inputs.		0.00 to 20.00 mA: if SEn is set to r7A (0000 to 20000) 0.00 to 10.00V: if SEn is set to u0LE (0000 to 10000) 0.00 to 50.00 mV: if SEn is set to r7u (0000 to 50000)	20.00 mA 5.00 V 50.00 mV	*75, 76 R/W (mA) *79, 80 R/W (V) *333, 334 R/W (mV)	SEn is set to r7A , SEn is set to u0LE , SEn is set to r7u .
P1.LE [P1.LE]	Process Input Low Error Set the low process value that will cause an error to occur for the process input.		-1.00 to 10.00 mA (-100 to 1000) -1.00 to 5.00 V (-100 to 500) -1.00 to 25.00 mV (-100 to 2500) (two decimal places implied for Modbus)	-1.00 mA -1.00 V -1.00 mV	325 R/W (mA) 327 R/W (V) 329 R/W (mV)	SEn is set to r7A , SEn is set to u0LE , SEn is set to r7u .
P1.HE [P1.HE]	Process Input High Error Set the high process value that will cause an error to occur for the process input.		10.00 to 21.00 mA (1000 to 2100) 5.00 to 11.00 V (500 to 1100) 25.00 to 51.00 mV (2500 to 5100) (two decimal places implied for Modbus)	21.00 mA 11.00 V 51.00 mV	326 R/W (mA) 328 R/W (V) 330 R/W (mV)	SEn is set to r7A , u0LE , or r7u .
rg.Lo [rg.Lo]	Units Scale Low Set the low range for process input units.		-1999 to 9999 (1999000 to 9999000) (Set precision with PdEC , Process Decimal Places.)	-1999	*81, 82 R/W	SEn is set to r7A , u0LE , or r7u .
rg.hi [rg.hi]	Units Scale High Set the high range for process input units.		-1999 to 9999 (-1999000 to 9999000) (Set precision with PdEC , Process Decimal Places.)	9999	*83, 84 R/W	SEn is set to r7A , u0LE , or r7u .

Note: Some values will be rounded off to fit in the four-character display. Full values can be read with Modbus. All temperature parameters through Modbus are in °F, by default. Writing to register 18 will toggle between °F and °C.

* Low register numbers contain the two higher bytes; high register numbers contain the two lower bytes of the four-byte integer. Decimal precision is implied at three decimal places unless otherwise noted.

** Static set point version only (SD_C-____-____).

*** Profiling version only (SD_R-____-____).

Display	Parameter Name Description	Settings	Range (Integer values for Modbus in parenthesis.)	Default	Modbus* (less 40,001 offset) Read/Write	Appears if:
[SP.Lo] [SP.Lo]	Set Point Low Limit Set the low range for the set point.		Min. operating range (of sensor) to [SP.Hi] - 0.100: if [SEn] is set to [tc] -328 to [SP.hi] -0.100: if [SEn] is set to [rtd] -1999 to [SP.hi] -0.001: if [SEn] is set to [r7A] , [uolt] or [r7u] . (Set precision with [PdEC] , Process Decimal Places.)	Min. operating range (J type): [tc] -328: [rtd] -999: [r7A] , [uolt] and [r7u] .	*240, 241 R/W (thermo-couple) *244, 245 R/W (RTD) *248, 249 R/W (mA, V or mV)	Always active.
[SP.hi] [SP.hi]	Set Point High Limit Set the high range for the set point.		[r9Lo] to max. operating range (of sensor): if [SEn] is set to [tc] [SP.Lo] +0.100 to 1472: if [SEn] is set to [rtd] [SP.Lo] +0.001 to 9999: if [SEn] is set to [r7A] , [uolt] or [r7u] . (Set precision with [PdEC] , Process Decimal Places)	Max. operating range (J type): [tc] 1472: [rtd] 999: [r7A] , [uolt] and [r7u] .	*242, 243 R/W (thermo-couple) *246, 247 R/W (RTD) *250, 251 R/W (mA, V or mV)	Always active.
[Ftr.E] [Ftr.E]	Input Filter Select filtering action.		[OFF] (0) (no filtering) [d.SP] (1) (filter only the display value) [CntL] (2) (filter the control input values) [both] (3)	[OFF] (0)	89 R/W	Always active.
[FLtr] [FLtr]	Filter Value Set the input filter value.		0.0 to 60.0 seconds (0000 to 60000)	0.0	*87, 88 R/W	[Ftr.E] is not set to [OFF] .
[Ot 1] [Ot 1]	Output 1 Function Set Output 1 function.		[OFF] Off (0) [PrAL] Process Alarm (1) [dEARL] Deviation Alarm (2) [HEAL] Heat Control (3) [Cool] Cool Control (4) [Event] Event (5) *** [r7rE] Retransmit (6)	[HEAL] (3)	143 R/W Always active.	Active only if Output 1 is a process output (SD_ _ _ F _ _ _ _ _)
[Ctr1] [Ctr1]	Control Method 1 Set output 1 control type. This parameter is only used with PID control, but can be set anytime.		[Ftb] Fixed Time Base (0) [UrTb] Variable Time Base (1)	[Ftb] (0)	144 R/W	[Ot 1] is set to [HEAL] or [Cool] and output type is SD_ _ _ C _ _ _ _ _ or SD_ _ _ K _ _ _ _ _
[Ftb1] [Ftb1]	Fixed Time Base 1 (Cycle Time) Set the time base for Fixed Time Base Control.		1.0 to 60.0 seconds if Output 1 is a mechanical relay (1000 to 60000) 0.1 to 60.0 seconds if Output 1 is not a mechanical relay (100 to 60000)	20.0: mech. relay 5.0: solid-state relay 1.0: switched dc	*145, 146 R/W	[Ot 1] is set to [HEAL] or [Cool] , [Ctr1] is set to [Ftb] and Output 1 is not a process output. (not SD_ _ _ F _ _ _ _ _)

Note: Some values will be rounded off to fit in the four-character display. Full values can be read with Modbus. All temperature parameters through Modbus are in °F, by default. Writing to register 18 will toggle between °F and °C.

* Low register numbers contain the two higher bytes; high register numbers contain the two lower bytes of the four-byte integer. Decimal precision is implied at three decimal places unless otherwise noted.

** Static set point version only (SD_C- _ _ _ _ _).

*** Profiling version only (SD_R- _ _ _ _ _).

Display	Parameter Name Description	Settings	Range (Integer values for Modbus in parenthesis.)	Default	Modbus* (less 40,001 offset) Read/Write	Appears if:
PL [PL 1]	Power Limit 1 Set the maximum power output for a control output		0.0 to 100.0% power (000 to 10000) (Two decimal places implied for Modbus.)	100.0%	160 R/W	DE is set to HEAT or COOL .
PSL [PSL1]	Output Power Scale Low 1 Set the low end of the range within which the output will scale.		0.0 to 100.0% (000 to 10000) (Two decimal places implied for Modbus.)	0%	161 R/W	DE is set to HEAT or COOL , CTR is set to FEB and Output 1 is not a process output. (not SD_ _ _ F_ _ _)
PSh [PSh1]	Output Power Scale High 1 Set the high end of the range within which the output will scale.		0.0 to 100.0% (000 to 10000) (Two decimal places implied for Modbus.)	100%	162 R/W	DE is set to HEAT or COOL , CTR is set to FEB and Output 1 is not a process output. (not SD_ _ _ F_ _ _)
nLF [nLF1]	Output Non-linear Function 1 Select a non-linear output curve to match the response of your system.	OFF Off (0) CRU1 curve 1 (1) CRU2 curve 2 (2)		OFF (0)	163 R/W	DE is set to HEAT or COOL .
AOU [AO1.U]	Analog Output 1 Units Set the analog output units.	MA milliamperes (0) VOLT volts (1)		MA (0)	147 R/W	Output 1 is a process output. (SD_ _ _ F_ _ _)
O1Lo [O1.Lo]	Analog Output 1 Scale Low Set the low scale for the process output.		0.00 to 20.00 mA if output is set to mA (0000 to 20000) 0.00 to 10.00V if output is set to volts (0000 to 10000)	4.00 mA 0.00V	*148, 149 R/W (mA) *152, 153 R/W (V)	Output 1 is a process output. (SD_ _ _ F_ _ _)
O1Hi [O1.hi]	Analog Output 1 Scale High Set the high scale for the process output		0.00 to 20.00 mA if output is set to mA (0000 to 20000) 0.00 to 10.00V if output is set to volts (0000 to 10000)	20.00 mA 10.00V	*150, 151 R/W (mA) *154, 155 R/W (V)	Output 1 is a process output. (SD_ _ _ F_ _ _)
r1So [r1.So]	Output 1 Retransmit Source Set the control variable that the retransmit signal represents.	PROC Process Value (0) SP Set Point (1)		PROC (0)	305 R/W	Output 1 is a process output (SD_ _ _ _ F_ _ _ _) and DE is set to CRU .
r1Lo [r1.Lo]	Output 1 Retransmit Low Scale Set the low scale for the retransmit output.		-1999.0 to 9999.0 (-1999000 to 9999000)	0	*306, 307 R/W	Output 1 is a process output (SD_ _ _ _ F_ _ _ _) and DE is set to CRU .
r1Hi [r1.hi]	Output 1 Retransmit High Scale Set the high scale for the retransmit output.		-1999.0 to 9999.0 (-1999000 to 9999000)	500	*308, 309 R/W	Output 1 is a process output (SD_ _ _ _ F_ _ _ _) and DE is set to CRU .

Note: Some values will be rounded off to fit in the four-character display. Full values can be read with Modbus. All temperature parameters through Modbus are in °F, by default. Writing to register 18 will toggle between °F and °C.

* Low register numbers contain the two higher bytes; high register numbers contain the two lower bytes of the four-byte integer. Decimal precision is implied at three decimal places unless otherwise noted.

** Static set point version only (SD_C- _ _ _ _).

*** Profiling version only (SD_R- _ _ _ _).

Display	Parameter Name Description	Settings	Range (Integer values for Modbus in parenthesis.)	Default	Modbus* (less 40,001 offset) Read/Write	Appears if:
<input type="checkbox"/> CO [r1.CO]	Output 1 Retransmit Offset Set the high scale for the process output.		-999.0 to 999.0 (-999000 to 999000)	0	*310, 311 R/W	Output 1 is a process output (SD_ _ - _ _ F - _ _ _) and <input type="checkbox"/> OE 1 is set to [rmt] .
<input type="checkbox"/> OE 2 [Ot 2]	Output 2 Function Set Output 2 function.		<input type="checkbox"/> OFF Off (0) <input type="checkbox"/> PrAL Process Alarm (1) <input type="checkbox"/> dEAL Deviation Alarm (2) <input type="checkbox"/> hERE Heat Control (3) <input type="checkbox"/> COOL Cool Control (4) <input type="checkbox"/> Event Event (5)***	<input type="checkbox"/> OFF (0)	167 R/W	Output 2 is installed and is not a communications output.
<input type="checkbox"/> ctr2 [Ctr2]	Control Method 2 Set Output 2 control type. This parameter is only used with PID control, but can be set anytime.		<input type="checkbox"/> Ftb Fixed Time Base (0) <input type="checkbox"/> Urtb Variable Time Base (1)	<input type="checkbox"/> Ftb (0)	168 R/W	<input type="checkbox"/> OE 2 is set to <input type="checkbox"/> hERE or <input type="checkbox"/> COOL and output type is SD_ _ - _ _ C _ _ - _ _ or SD_ _ - _ _ K _ _ - _ _ .
<input type="checkbox"/> Ftb2 [Ftb2]	Fixed Time Base 2 (Cycle Time) Set the time base for Fixed Time Base Control.		1.0 to 60.0 seconds if Output 2 is mechanical relay (1000 to 60000) 0.1 to 60.0 seconds if Output 2 is not a mechanical relay (100 to 60000)	20.0 (mech. relay) 5.0 (solid-state relay) 1.0 (switched dc)	*169, 170 R/W	<input type="checkbox"/> OE 2 is set to <input type="checkbox"/> hERE or <input type="checkbox"/> COOL , and <input type="checkbox"/> ctr2 is <input type="checkbox"/> Ftb .
<input type="checkbox"/> PL 2 [PL 2]	Power Limit 2 Set maximum power output for a control output.		0.0 to 100.0% power (000 to 10000) (Two decimal places implied for Modbus.)	100.0%	171 R/W	<input type="checkbox"/> OE 2 is set to <input type="checkbox"/> hERE or <input type="checkbox"/> COOL .
<input type="checkbox"/> PSL2 [PSL2]	Output Power Scale Low 2 Set the low end of the range within which the output will scale.		0.0 to 100.0% (000 to 10000) (Two decimal places implied for Modbus.)	0%	172 R/W	<input type="checkbox"/> OE 2 is set to <input type="checkbox"/> hERE or <input type="checkbox"/> COOL , <input type="checkbox"/> ctr2 is set to <input type="checkbox"/> Ftb and Output 2 is not a communications output. (not SD_ _ - _ _ U _ - _ _ _)
<input type="checkbox"/> PSh2 [PSh2]	Output Power Scale High 2 Set the high end of the range within which the output will scale.		0.0 to 100.0% (000 to 10000) (Two decimal places implied for Modbus.)	100.0%	173 R/W	<input type="checkbox"/> OE 2 is set to <input type="checkbox"/> hERE or <input type="checkbox"/> COOL , <input type="checkbox"/> ctr2 is set to <input type="checkbox"/> Ftb and Output 2 is not a communications output. (not SD_ _ - _ _ U _ - _ _ _)
<input type="checkbox"/> nLF2 [nLF2]	Output Non-linear Function 2 Select a non-linear output curve to match the response of your system.		<input type="checkbox"/> OFF Off (0) <input type="checkbox"/> CrV1 curve 1 (1) <input type="checkbox"/> CrV2 curve 2 (2)	<input type="checkbox"/> OFF (0)	174 R/W	<input type="checkbox"/> OE 2 is set to <input type="checkbox"/> hERE or <input type="checkbox"/> COOL .
<input type="checkbox"/> OE 3 [Ot 3]	Output 3 Function Set Output 3 function.		<input type="checkbox"/> OFF Off (0) <input type="checkbox"/> PrAL Process Alarm (1) <input type="checkbox"/> dEAL Deviation Alarm (2) <input type="checkbox"/> hERE Heat Control (3) <input type="checkbox"/> COOL Cool Control (4) <input type="checkbox"/> Event Event (5)*** <input type="checkbox"/> rRET Retransmit (6)	<input type="checkbox"/> OFF (0)	178 R/W	Output 3 is installed. Active only if Output 3 is a process output (SD_ _ - _ _ F - _ _ _)

Note: Some values will be rounded off to fit in the four-character display. Full values can be read with Modbus. All temperature parameters through Modbus are in °F, by default. Writing to register 18 will toggle between °F and °C.

* Low register numbers contain the two higher bytes; high register numbers contain the two lower bytes of the four-byte integer. Decimal precision is implied at three decimal places unless otherwise noted.

** Static set point version only (SD_C- _ _ _ - _ _ _ _).

*** Profiling version only (SD_R- _ _ _ - _ _ _ _).

Display	Parameter Name Description	Settings	Range (Integer values for Modbus in parenthesis.)	Default	Modbus* (less 40,001 offset) Read/Write	Appears if:
[Ctr3] [Ctr3]	Control Method 3 Set Output 3 control type. This parameter is only used with PID control, but can be set anytime.		[Ftb] Fixed Time Base (0) [Urtb] Variable Time Base (1)	[Ftb] (0)	179 R/W	[Oe3] is set to [HEAT] or [COOL] and output type is SD_ _ _ _ C _ _ _ or SD_ _ _ _ K _ _ _.
[Ftb3] [Ftb3]	Fixed Time Base 3 (Cycle Time) Set the time base for Fixed Time Base Control.		1.0 to 60.0 seconds if Output 3 is a mechanical relay (1000 to 60000) 0.1 to 60.0 seconds if Output 3 is not a mechanical relay (100 to 60000)	20.0 (mech. relay) 5.0 (solid-state relay) 1.0 (switched dc)	*180, 181 R/W	[Oe3] is set to [HEAT] or [COOL] , and [Ctr3] is set to [Ftb] , and Output 3 is not a process output. (not SD_ _ _ _ F _ _ _)
[PL3] [PL3]	Power Limit 3 Set the maximum power output for a control output.		0.0 to 100.0% (000 to 10000) (Two decimal places implied for Modbus.)	100.0%	195 R/W	[Oe3] is set to [HEAT] or [COOL] .
[PSL3] [PSL3]	Output Power Scale Low 3 Set the low end of the range within which the output will scale.		0.0 to 100.0% (000 to 10000) (Two decimal places implied for Modbus.)	0%	196 R/W	[Oe3] is set to [HEAT] or [COOL] , [Ctr3] is set to [Ftb] and Output 3 is not a process output. (not SD_ _ _ _ F _ _ _)
[PSH3] [PSH3]	Output Power Scale High 3 Set the high end of the range within which the output will scale		0.0 to 100.0% (000 to 10000) (Two decimal places implied for Modbus.)	100.0%	197 R/W	[Oe3] is set to [HEAT] or [COOL] , [Ctr3] is set to [Ftb] and Output 3 is not a process output (not SD_ _ _ _ F _ _ _).
[nLF3] [nLF3]	Output Non-linear Function 3 Select a non-linear output curve to match the response of your system.		[OFF] Off (0) [Cr1] curve 1 (1) [Cr2] curve 2 (2)	[OFF] (0)	198 R/W	[Oe3] is set to [HEAT] or [COOL] .
[AO3.U] [AO3.U]	Analog Output 3 Units Set the analog process output units.		[PTA] milliamperes (0) [VOLT] volts (1)	[PTA] (0)	182 R/W	Output 3 is a process output. (SD_ _ _ _ F _ _ _)
[O3.Lo] [O3.Lo]	Output 3 Low Scale Set the low scale for the process output.		0.00 to 20.00 mA if output is set to mA (0000 to 20000) 0.00 to 10.00V if output is set to volts (0000 to 10000)	4.00 mA 0.00V	*183, 184 R/W (mA) *187, 188 R/W (V)	Output 3 is a process output. (SD_ _ _ _ F _ _ _)
[O3.Hi] [O3.Hi]	Output 3 High Scale Set the high scale for the process output.		0.00 to 20.00 mA if output is set to mA (0000 to 20000) 0.00 to 10.00V if output is set to volts (0000 to 10000)	20.00 mA 10.00V	*185, 186 R/W (mA) *189, 190 R/W (V)	Output 3 is a process output. (SD_ _ _ _ F _ _ _)
[r3.So] [r3.So]	Output 3 Retransmit Source Set the control variable that the retransmit signal represents.		[Proc] Process Value (0) [SP] Set Point (1)	[Proc] (0)	315 R/W	Output 3 is a process output (SD_ _ _ _ F _ _ _) and [Oe3] is set to [rTE] .

Note: Some values will be rounded off to fit in the four-character display. Full values can be read with Modbus. All temperature parameters through Modbus are in °F, by default. Writing to register 18 will toggle between °F and °C.

* Low register numbers contain the two higher bytes; high register numbers contain the two lower bytes of the four-byte integer. Decimal precision is implied at three decimal places unless otherwise noted.

** Static set point version only (SD_C- _ _ _ _ - _ _ _ _).

*** Profiling version only (SD_R- _ _ _ _ - _ _ _ _).

Display	Parameter Name Description	Settings	Range (Integer values for Modbus in parenthesis.)	Default	Modbus* (less 40,001 offset) Read/Write	Appears if:
r3Lo [r3.Lo]	Output 3 Retransmit Low Scale Set the low scale for the retransmit output.		-1999.0 to 9999.0 (-1999000 to 9999000)	0	*316, 317 R/W	Output 3 is a process output (SD__-___F-____) and DE 3 is set to rPnE .
r3hi [r3.hi]	Output 3 Retransmit High Scale Set the high scale for the retransmit output.		-1999.0 to 9999.0 (-1999000 to 9999000)	500	*318, 319 R/W	Output 3 is a process output (SD__-___F-____) and DE 3 is set to rPnE .
r3CO [r3.CO]	Output 3 Retransmit Offset Set the offset value for the retransmit output.		-999.0 to 999.0 (-999000 to 999000)	0	*320, 321 R/W	Output 3 is a process output (SD__-___F-____) and DE 3 is set to rPnE .
hyS1 [hyS1]	Alarm 1 Hysteresis Set the hysteresis for an alarm. This determines how far into the safe region the input needs to move before the alarm can be cleared.		0.0 to 999.0 (0000 to 999000)	1.0	*106, 107 R/W	DE 1 is set to dEAL or PcAL .
Lgc1 [Lgc1]	Alarm 1 Logic Select the alarm output condition in the alarm state.		AL C closed on alarm (0) AL O open on alarm (1)	AL C (0)	164 R/W	DE 1 is set to dEAL or PcAL .
LAt1 [LAt1]	Alarm 1 Latching Turn J on or off.		nLAE off (0) LAE on (1)	nLAE (0)	108 R/W	DE 1 is set to dEAL or PcAL .
SiL1 [SiL1]	Alarm 1 Silencing Turn alarm silencing on or off.		OFF off (0) no silencing On on (1) silencing	OFF (0)	109 R/W	DE 1 is set to dEAL or PcAL .
dSP1 [dSP1]	Alarm 1 Message Displays an alarm message when an alarm is active.		OFF off (0) no message On on (1) message	On (1)	110 R/W	DE 1 is set to dEAL or PcAL .
hyS2 [hyS2]	Alarm 2 Hysteresis Set the hysteresis for an alarm. This determines how far into the safe region the input needs to move before the alarm can be cleared.		0.0 to 999.0 (0000 to 999000)	1.0	*121, 122 R/W	DE 2 is set to dEAL or PcAL .
Lgc2 [Lgc2]	Alarm 2 Logic Select the alarm output condition in the alarm state.		AL C closed on alarm (0) AL O open on alarm (1)	AL C (0)	175 R/W	DE 2 is set to dEAL or PcAL .
LAt2 [LAt2]	Alarm 2 Latching Turn alarm latching on or off.		nLAE off (0) LAE on (1)	nLAE (0)	123 R/W	DE 2 is set to dEAL or PcAL .
SiL2 [SiL2]	Alarm 2 Silencing Turn alarm silencing on or off.		OFF off (0) no silencing On on (1) silencing	OFF (0)	124 R/W	DE 2 is set to dEAL or PcAL .
dSP2 [dSP2]	Alarm 2 Message Displays an alarm message when an alarm is active.		OFF off (0) no message On on (1)	On (1)	125 R/W	DE 2 is set to dE;AL or PcAL .

Note: Some values will be rounded off to fit in the four-character display. Full values can be read with Modbus. All temperature parameters through Modbus are in °F, by default. Writing to register 18 will toggle between °F and °C.

* Low register numbers contain the two higher bytes; high register numbers contain the two lower bytes of the four-byte integer. Decimal precision is implied at three decimal places unless otherwise noted.

** Static set point version only (SD_C-____-____).

*** Profiling version only (SD_R-____-____).

Display	Parameter Name Description	Settings	Range (Integer values for Modbus in parenthesis.)	Default	Modbus* (less 40,001 offset) Read/Write	Appears if:
[hyS3] [hyS3]	Alarm 3 Hysteresis Set the hysteresis for an alarm. This determines how far into the safe region the input needs to move before the alarm can be cleared.		0.0 to 999.0 (0000 to 999000)	1.000	*136, 137 R/W	[DE 3] is set to [dE;AL] or [Pr.AL] .
[Lgc3] [Lgc3]	Alarm 3 Logic Select the alarm output condition in the alarm state.		[AL C] closed on alarm (0) [AL 0] open on alarm (1)	[AL C] (0)	199 R/W	[DE 3] is set to [dEAL] .
[LAt3] [LAt3]	Alarm 3 Latching Turn alarm latching on or off.		[nLAt] off (0) [LAt] on (1)	[nLAt] (0)	138 R/W	[DE 3] is set to [dEAL] or [Pr.AL] .
[SiL3] [SiL3]	Alarm 3 Silencing Turn alarm silencing on or off.		[OFF] off (0) no silencing [On] on (1) silencing	[OFF] (0)	139 R/W	[DE 3] is set to [dEAL] or [Pr.AL] .
[dSP3] [dSP3]	Alarm 3 Message Displays an alarm message when an alarm is active.		[OFF] off (0) no message [On] on (1) message	[On] (1)	140 R/W	[DE 3] is set to [dEAL] or [Pr.AL] .
[Unit] [Unit]	AC Line Frequency Set the frequency of the applied AC line power source.		[50] 50 (0) [60] 60 (1)	[60] (1)	276 R/W	If [Ct r 1] , [Ct r 2] or [Ct r 3] is set to [Ur t b] .
[Unit] [Unit]	Units of Measurement Set the type of units used for the PID control parameters.		[US] US (0) [SI] SI (1)	[US] (0)	45 R/W	Always active.
[I.Err] [I.Err]	Input Error Latching Turn input error latching on or off.		[nLAt] off (0) [LAt] on (1)	[nLAt] (0)	90 R/W	Always active.
[FAIL] [FAIL]	Input Error Failure Mode Set the input error failure mode when an error is detected and the control changes to manual mode.		[OFF] off (0) (0% power) [bPLS] bumpless (1) (current power level) [PMan] manual (2) (fixed power level)	[bPLS] (1)	252 R/W	Always active.
[MAN] [MAN]	Input Error Power Set the manual power level when an input error causes a change to manual mode.		-100.0 to 100.0% (-10000 to 10000)	0.0%	253 R/W	[FAIL] is set to [PMan] .
[dSP] [dSP]	Active Displays Select which displays are active.		[nOr] both displays on (0) [SE] lower display only (1) [PrO] upper display only (2)	[nOr] (0)	44 R/W	Always active.
[rP] [rP]	Ramping Mode** Select when the control set point ramps to the defined end set point.		[OFF] off (0) [SEr] ramps on start-up only (1) [On] ramps at start-up or any set point change (2)	[OFF] (0)	266 R/W	Static set point version only. (SD_C-____-____)

Note: Some values will be rounded off to fit in the four-character display. Full values can be read with Modbus. All temperature parameters through Modbus are in °F, by default. Writing to register 18 will toggle between °F and °C.

* Low register numbers contain the two higher bytes; high register numbers contain the two lower bytes of the four-byte integer. Decimal precision is implied at three decimal places unless otherwise noted.

** Static set point version only (SD_C-____-____).

*** Profiling version only (SD_R-____-____).

Display	Parameter Name Description	Settings	Range (Integer values for Modbus in parenthesis.)	Default	Modbus* (less 40,001 offset) Read/Write	Appears if:
rPSc [rP.Sc]	Ramp Scale** Select the scale of the ramp rate.		hour degrees/hour (0) min degrees/minute (1)	hour (0)	267 R/W	rP is set to Scr or On .
rPrE [rP.rt]	Ramp Rate** Set the rate for the set point ramp.		0 to 9999 (0000 to 9999000)	100	*268, 269 R/W	rP is set to Scr or On . Does not appear if rP is set to OFF .
PtYP [PtyP]	Profile Type*** Set the profile ramp to time based or rate based.		Tr Time based ramp (0) rRE Rate based ramp (1)	Tr (0)	354 R/W	Profiling version only. (SD_R - - - - -)
PStE [PStr]	Profile Start*** Select where the profile begins the starting set point of the profile, current static set point or current process temperature.		SEt Static Set Point (0) Pro Process (1)	SEt (0)	355 R/W	Profiling version only. (SD_R - - - - -)
gSdE [gS.dE]	Guaranteed Soak Deviation Enable*** Enables the guaranteed soak deviation function in profiles.		no Disabled (0) YES Enabled (1)	no (0)	356 R/W	Profiling version only. (SD_R - - - - -)
gSd [gSd]	Guaranteed Soak Deviation Value*** Set the value of deviation allowed by the guaranteed soak deviation function.		1 to 999 (1000 to 999000)	1	*357, 358 R/W	Profiling version only. (SD_R - - - - -) gSdE is set to YES .
Addr [Addr]	Modbus Device Address Set the device address for communications. Every controller on a network must have a unique address.		1 to 247	1	This can only be set from the controller front panel.	Output 2 is a communications output. (SD_ - - - - - U - - - - -)
bAud [bAud]	Baud Rate Set the baud rate at which the communications occurs.		9600 192 384	9600	This can only be set from the controller front panel.	Output 2 is a communications output. (SD_ - - - - - U - - - - -)
t.tun [t.tun]	TRU-TUNE+™ Enable Enable or disable the TRU-TUNE+™ adaptive tuning feature.		no No (0) YES Yes (1)	YES	350 rw	TRU-TUNE+™ version only. (SD_E - - - - -)
AgrS [AgrS]	Autotune Aggressiveness Select the aggressiveness of the autotuning calculations. (This does not affect the TRU-TUNE+™ function.)		Undr Under (0) Crit Critical (1) Over Over (2)	Undr Under [0]	351 rw	
t.bnd [t.bnd]	Tune Band Set the range, centered on the set point, within which TRU-TUNE+™ will be in effect. Use this function only if the controller is unable to adaptive tune automatically.		0 Auto 1 to 999 Degrees or Units	0 Auto	353 rw	TRU-TUNE+™ version only. (SD_E - - - - -)

Note: Some values will be rounded off to fit in the four-character display. Full values can be read with Modbus. All temperature parameters through Modbus are in °F, by default. Writing to register 18 will toggle between °F and °C.

* Low register numbers contain the two higher bytes; high register numbers contain the two lower bytes of the four-byte integer. Decimal precision is implied at three decimal places unless otherwise noted.

** Static set point version only (SD_C- - - - -).

*** Profiling version only (SD_R- - - - -).

Display	Parameter Name Description	Settings	Range (Integer values for Modbus in parenthesis.)	Default	Modbus* (less 40,001 offset) Read/Write	Appears if:
<input type="text" value="E.gn"/> [t.gn]	Tune Gain Select the responsiveness of the TRU-TUNE+™ adaptive tuning calculations. More responsiveness may increase overshoot.		1 to 7 Least to most responsive.	4	354 rw	TRU-TUNE+™ version only. (SD_E - _ _ _ _ - _ _ _ _).
<input type="text" value="LOC"/> [LOC]	Lockout Set the security level for the user interface.		<input type="text" value="0"/> (0) no lockout *** Full profile access. <input type="text" value="1"/> (1) Set Point, Auto/Manual, alarms only. *** Full profile access <input type="text" value="2"/> (2) Set Point, Auto/Manual, only. *** Pre-Run and Run Menu access only. View a running profile. Profile editing not permitted. <input type="text" value="3"/> (3) Set Point only *** Profile access not permitted. <input type="text" value="4"/> (4) full lockout *** Profile access not permitted. See the Features chapter for details.	<input type="text" value="0"/> (0)	43 R/W	Always active.



Note: Some values will be rounded off to fit in the four-character display. Full values can be read with Modbus. All temperature parameters through Modbus are in °F, by default. Writing to register 18 will toggle between °F and °C.

* Low register numbers contain the two higher bytes; high register numbers contain the two lower bytes of the four-byte integer. Decimal precision is implied at three decimal places unless otherwise noted.

*** Static set point version only (SD_C- _ _ _ _ - _ _ _ _).

*** Profiling version only (SD_R- _ _ _ _ - _ _ _ _).

6 Chapter 6: Operations Parameters Table

These parameters can be selected to appear in the Operations Page. Select the parameters you want to appear in the Operations Page in the Programming Page. Press the Advance Key  to enter the Operations Page and to step through the parameters. For profiling controllers, set **[Prog]** to **[no]** to access the Operations Page. Press the Infinity Key  to return to the Home Page at any time.

Note: This chapter only applies to the static set point and profiling versions of the Series SD (SD_C or R - ____ - ____).

Note: The Operations Page is not accessible when a profile is running.

Display	Parameter name Description	Settings	Range	Default	Modbus* (less 40,001 offset) Read/Write	Appears if'
[Po.hE] [Po.ht]	Power Heat Displays the current heat control power.		0.0 to 100.0% power (000 to 10000) (Two decimal places implied for Modbus.)	NA	256 R	[A-M] is set to [Auto] and at least one output is set to [Heat] .
[Po.CL] [Po.CL]	Power Cool Displays the current cool control power.		0.0 to 100.0% power (000 to 10000) (Two decimal places implied for Modbus.)	NA	257 R	[A-M] is set to [Auto] and at least one output is set to [Cool] .
[A-M] [A-M]	Auto-Manual Mode Set the control mode.	[Auto] (0) [MAN] (1)		[Auto] (0)	25 R/W	Always appears.
[Aut] [Aut]	Autotune Start an autotune.	[OFF] off (0) [On] on (1)		[OFF] (0)	215 R/W	At least one output is set to [Heat] or [Cool] .
[CAL] [CAL]	Calibration Offset Offset the input reading.		-999 to 999 (-999000 to 999000)	0.0	*85, 86 R/W	Always appears.
[ht.M] [ht.M]	Heat Control Method Set the heat control method.	[OFF] off (0) [PID] PID (1) [onoff] on-off (2)		[PID] (1)	213 R/W	At least one output is set to [Heat] .
[Pb.ht] [Pb.ht]	Proportional Band Heat Set the proportional band for the heat outputs.		1 to 999°F, if [SEN] is set to [Ea] or [rEd] (1000 to 999000) 0.000 to 999 units, if [SEN] is set to [MAN] or [Auto] . (0000 to 999000)	25 25	*216, 217 R/W *220, 221 R/W	At least one output is set to [Heat] and [ht.M] is set to [PID] .
[rE.ht] [rE.ht]	Reset Heat Set the PID reset in repeats per minute for the heat outputs.		0.00 to 99.99 repeats per minute (0000 to 99990) 0.00: disabled	0.00	*224, 225 R/W (Modbus value is integral, which is the inverse of reset.)	At least one output is set to [Heat] , [ht.M] is set to [PID] , and [Unit] is set to [US] .

Note: Parameters appear in the Operations Page only if activated from the programming page. See page 22 for Operations Page defaults.

Note: Some values will be rounded off to fit in the four-character display. Full values can be read with Modbus. All temperature parameters through Modbus are in °F, by default.

* Low register numbers contain the two higher bytes; high register numbers contain the two lower bytes of the four-byte integer. Decimal precision is implied at three decimal places unless otherwise noted.

** Static set point version only (SD_C-____-____).

*** Profiling version only (SD_R-____-____).

**** This value multiplied by 100 equals the percent power.

Display	Parameter name Description	Settings	Range	Default	Modbus* (less 40,001 offset) Read/Write	Appears if"
[It.ht] [It.ht]	Integral Heat Set the PID integral in minutes per repeat for the heat outputs.		0.00 to 99.99 minutes/per repeat (0000 to 99990) 0.00: disabled	0.00	*224, 225 R/W	At least one output is set to [HEAT] , [TEMP] is set to [PID] , and [UNIT] is set to [SI] .
[rA.ht] [rA.ht]	Rate Heat Set the PID rate time in minutes for the heat output.		0.00 to 9.99 minutes (0000 to 9990) 0.00: disabled	0.00	*228, 229 R/W	At least one output is set to [HEAT] , [TEMP] is set to [PID] , and [UNIT] is set to [US] .
[dE.ht] [dE.ht]	Derivative Heat Set the PID derivative time in minutes for the heat outputs.		0.00 to 9.99 minutes (0000 to 9990) 0.00: disabled	0.00	*228, 229 R/W	At least one output is set to [HEAT] , [TEMP] is set to [PID] , and [UNIT] is set to [SI] .
[db.ht] [db.ht]	Dead Band Heat An offset of the heating proportional band from the set point.		0 to 999 (0000 to 999000)	0	*279, 280 R/W	At least one output is set to [HEAT] and [TEMP] is set to PID.
[h.hyS] [h.hyS]	Heat Hysteresis Set the control switching hysteresis for on-off control. This determines how far into the "on" region the input needs to move before the output actually turns on.		1 to 999 degrees, if [SEN] is set to [EC] or [rtd] (1000 to 999000) 0.000 to 999.999 units, if [SEN] is set to [PFR] or [uolt] (0000 to 999999)	1.0 1.000	*232, 233 R/W *234, 235 R/W	At least one output is set to [HEAT] , and [TEMP] is set to [onof] .
[CL.M] [CL.M]	Cool Control Method Set the Cool Control Method		[OFF] off (0) [PID] PID (1) [onof] on-off (2)	[OFF] (0)	214 R/W	At least one output is set to [Cool] .
[Pb.CL] [Pb.CL]	Proportional Band Cool Set the proportional band for the cool outputs.		1 to 999°F if [SEN] is set to [EC] or [rtd] (1000 to 999000) 0.000 to 999.0 if [SEN] is set to [PFR] or [uolt] (0000 to 999000)	25 25.000	*218, 219 R/W *222, 223 R/W	At least one output is set to [Cool] , and [CL.M] is set to [PID] .
[rE.CL] [rE.CL]	Reset Cool Set the PID reset in repeats per minute for the cool output.		0.00 to 99.99 repeats per minute (0000 to 99990) 0.00: disabled	0.00	*226, 227 R/W (Modbus value is integral, which is the inverse of reset.)	At least one output is set to [Cool] , [CL.M] is set to [PID] , and [UNIT] is set to [US] .
[It.CL] [It.CL]	Integral Cool Set the PID integral in minutes per repeat for the cool outputs.		0.00 to 99.99 minutes per repeat (0000 to 99990) 0.00: disabled	0.00	*226, 227 R/W	At least one output is set to [Cool] , [CL.M] is set to [PID] , and [UNIT] is set to [SI] .
[rA.CL] [rA.CL]	Rate Cool Set the PID rate time in minutes for the cool outputs.		0.00 to 9.99 minutes (0000 to 99990) 0.00: disabled	0.00	*230, 231 R/W	At least one output is set to [Cool] , [CL.M] is set to [PID] , and [UNIT] is set to [US] .

Note: Parameters appear in the Operations Page only if activated from the programming page. See page 22 for Operations Page defaults.

Note: Some values will be rounded off to fit in the four-character display. Full values can be read with Modbus. All temperature parameters through Modbus are in °F, by default.

* Low register numbers contain the two higher bytes; high register numbers contain the two lower bytes of the four-byte integer. Decimal precision is implied at three decimal places unless otherwise noted.

** Static set point version only (SD_C-____-____).

*** Profiling version only (SD_R-____-____).

**** This value multiplied by 100 equals the percent power.

Display	Parameter name Description	Settings	Range	Default	Modbus* (less 40,001 offset) Read/Write	Appears if"
[dE.CL] [dE.CL]	Derivative Cool Set the PID derivative time in minutes for the cool outputs.		0.00 to 9.99 minutes (0000 to 99990) 0.00: disabled	0.00	*230, 231 R/W	At least one output is set to [Cool] , [CLP7] is set to [PID] , and [Unit] is set to [SI] .
[db.CL] [db.CL]	Dead Band Cool An offset of the cooling proportional band from the set point.		0 to 999 (0000 to 999000)	0	*281, 282 R/W	At least one output is set to [Cool] and [CLP7] is set to [PID] .
[ChyS] [C.hyS]	Cool Hysteresis Set the control switching hysteresis for on/off control. This determines how far into the "on" region the input needs to move before the output actually turns on.		1 to 999°F if [SEN] is set to [tc] or [rtd] (1000 to 999000) 0.000 to 999.9 if [SEN] is set to [P7A] or [uolt] (0000 to 999000)	1 1.000	*236, 237 R/W *238, 239 R/W	At least one output is set to [Cool] and [CLP7] is set to [onoff] .
[Prop] [Prop]	Proportional Term View the active proportional term for PID diagnostics.		0.000 to 1.000**** (0000 to 1000)	NA	258 R	Any output is set to [HEAT] or [Cool] .
[it] [it]	Integral Term View the active integral term for PID diagnostics.		0.000 to 1.000**** (0000 to 1000)	NA	259 R	Any output is set to [HEAT] or [Cool] .
[dE] [dE]	Derivative Term View the active derivative term for PID diagnostics.		0.000 to 1.000**** (0000 to 1000)	NA	260 R	Any output is set to [HEAT] or [Cool] .
[Ent1] [Ent1]	Event Output 1*** Set Event Output 1 to an on or off state.		[off] (0) Output is off [on] (1) Output is on	[off] (0)	351 R/W	Profiling version only. (SD_R-____-_____) Output 1 is set to [Ent1] .
[Ent2] [Ent2]	Event Output 2*** Set Event Output 2 to an on or off state.		[off] (0) Output is off [on] (1) Output is on	[off] (0)	352 R/W	Profiling version only. (SD_R-____-_____) Output 2 is set to [Ent2] .
[Ent3] [Ent3]	Event Output 3*** Set Event Output 3 to an on or off state.		[off] (0) Output is off [on] (1) Output is on	[off] (0)	353 R/W	Profiling version only. (SD_R-____-_____) Output 3 is set to [Ent3] .
[Al.hi] [Al.hi]	Alarm 1 High Set the high alarm set point.		Deviation: 0 to 9999 (0000 to 9999000) Process: range of sensor, if [SEN] is set to [tc] or [rtd] -1999 to 9999 if [SEN] is set to [P7A] or [uolt] . (-1999000 to 9999000)	999 (dev) 1500 (pro)	*100, 101 R/W (dev) *104, 105 R/W (pro)	[DEI] is set to [dEAL] or [PrAL] .

Note: Parameters appear in the Operations Page only if activated from the programming page. See page 22 for Operations Page defaults.

Note: Some values will be rounded off to fit in the four-character display. Full values can be read with Modbus. All temperature parameters through Modbus are in °F, by default.

* Low register numbers contain the two higher bytes; high register numbers contain the two lower bytes of the four-byte integer. Decimal precision is implied at three decimal places unless otherwise noted.

** Static set point version only (SD_C-____-____).

*** Profiling version only (SD_R-____-____).

**** This value multiplied by 100 equals the percent power.

Display	Parameter name Description	Settings	Range	Default	Modbus* (less 40,001 offset) Read/Write	Appears if"
[A1.Lo] [A1.Lo]	Alarm 1 Low Set the low alarm set point.		Deviation: -1999 to 0 (-1999000 to 0000) Process: range of sensor, if [SEN] is set to [tc] or [rtd] -1999 to 9999 if [SEN] is set to [P7A] or [uolt] . (-1999000 to 9999000)	-999 (dev) 32 (pro)	*98, 99 R/W (dev) *102, 103 R/W (pro)	[DE 1] is set to [dEARL] or [PrAL] .
[A2.hi] [A2.hi]	Alarm 2 High Set the high alarm set point.		Deviation: 0 to 9999 (0000 to 9999000) Process: range of sensor, if [SEN] is set to [tc] or [rtd] -1999 to 9999 if [SEN] is set to [P7A] or [uolt] . (-1999000 to 9999000)	999 (dev) 1500 (pro)	*115, 116 R/W (dev) *119, 120 R/W (pro)	[DE 2] is set to [dEARL] or [PrAL] .
[A2.Lo] [A2.Lo]	Alarm 2 Low Set the low alarm set point.		Deviation: -1999 to 0 (-1999000 to 0000) Process: range of sensor, if [SEN] is set to [tc] or [rtd] -1999 to 9999 if [SEN] is set to [P7A] or [uolt] . (-1999000 to 9999000)	-999 (dev) 32 (pro)	*113, 114 R/W (dev) *117, 118 R/W (pro)	[DE 2] is set to [dEARL] or [PrAL] .
[A3.hi] [A3.hi]	Alarm 3 High Set the high alarm set point.		Deviation: 0 to 9999 (0000 to 9999000) Process: range of sensor, if [SEN] is set to [tc] or [rtd] -1999 to 9999 if [SEN] is set to [P7A] or [uolt] . (-1999000 to 9999000)	999 (dev) 1500 (pro)	*130, 131 R/W (dev) *134, 135 R/W (pro)	[DE 3] is set to [dEARL] or [PrAL] .
[A3.Lo] [A3.Lo]	Alarm 3 Low Set the low alarm set point.		Deviation: -1999 to 0 (-1999000 to 0000) Process: range of sensor, if [SEN] is set to [tc] or [rtd] -1999 to 9999 if [SEN] is set to [P7A] or [uolt] . (-1999000 to 9999000)	-999 (dev) 32 (pro)	*128, 129 R/W (dev) *132, 133 R/W (pro)	[DE 3] is set to [dEARL] or [PrAL] .

Note: Parameters appear in the Operations Page only if activated from the programming page. See page 22 for Operations Page defaults.

Note: Some values will be rounded off to fit in the four-character display. Full values can be read with Modbus. All temperature parameters through Modbus are in °F, by default.

* Low register numbers contain the two higher bytes; high register numbers contain the two lower bytes of the four-byte integer. Decimal precision is implied at three decimal places unless otherwise noted.



** Static set point version only (SD_C-____-____).

*** Profiling version only (SD_R-____-____).

**** This value multiplied by 100 equals the percent power.

7

Chapter 7: Operations Parameters Table for TRU-TUNE+™

These parameters can be selected to appear in the Operations Page. Select the parameters you want to appear in the Operations Page in the Programming Page. Press the Advance Key  to enter the Operations Page and to step through the parameters. For profiling controllers, set **[Prog]** to **[no]** to access the Operations Page. Press the Infinity Key  to return to the Home Page at any time.

Note: This chapter only applies to the TRU-TUNE+™ version of the Series SD (SD_E - _____).

Display	Parameter name Description	Settings	Range	Default	Modbus* (less 40,001 offset) Read/Write	Appears if'
[PohE] [Po.ht]	Power Heat Displays the current heat control power.		0.0 to 100.0% power (000 to 10000) (Two decimal places implied for Modbus.)	NA	256 R	[A-M] is set to [Auto] and at least one output is set to [Heat] .
[PocL] [Po.CL]	Power Cool Displays the current cool control power.		0.0 to 100.0% power (000 to 10000) (Two decimal places implied for Modbus.)	NA	257 R	[A-M] is set to [Auto] and at least one output is set to [Cool] .
[A-M] [A-M]	Auto-Manual Mode Set the control mode.		[Auto] (0) [MAN] (1)	[Auto] (0)	25 R/W	Always appears.
[Aut] [Aut]	Autotune Start an autotune.		[OFF] off (0) [On] on (1)	[OFF] (0)	215 R/W	At least one output is set to [Heat] or [Cool] .
[t.tun] [t.tun]	TRU-TUNE+™ Enable Enable or disable the TRU TUNE+™ adaptive tuning feature.		[no] No (0) [YES] Yes (1)	[YES]	350 rw	TRU-TUNE+™ version only. (SD_E - _____).
[CAL] [CAL]	Calibration Offset Offset the input reading.		-999 to 999 (-999000 to 999000)	0.0	*85, 86 R/W	Always appears.
[ht.M] [ht.M]	Heat Control Method Set the heat control method.		[OFF] off (0) [PID] PID (1) [on-off] on-off (2)	[PID] (1)	213 R/W	At least one output is set to [Heat] .
[Pb.ht] [Pb.ht]	Proportional Band Heat Set the proportional band for the heat outputs.		1 to 999°F, if [SEN] is set to [tc] or [rtd] (1000 to 999000) 0.000 to 999 units, if [SEN] is set to [MAN] or [voltage] . (0000 to 999000)	25 25	*335, 336 R/W *339, 340 R/W	At least one output is set to [Heat] and [ht.M] is set to [PID] .
[It.hc] [It.hc]	Integral Set the PID integral in seconds per repeat for all outputs.		0.00 to 3,600 seconds per repeat (0000 to 3600) 0.00: disabled	180.0	*343, 344 R/W	TRU-TUNE+™ version only. (SD_E - _____). [ht.M] and/or [CAL] is set to [PID] .

Note: Parameters appear in the Operations Page only if activated from the programming page. See page 22 for Operations Page defaults.

Note: Some values will be rounded off to fit in the four-character display. Full values can be read with Modbus. All temperature parameters through Modbus are in °F, by default.

* Low register numbers contain the two higher bytes; high register numbers contain the two lower bytes of the four-byte integer. Decimal precision is implied at three decimal places unless otherwise noted.

**** This value multiplied by 100 equals the percent power.

Display	Parameter name Description	Settings	Range	Default	Modbus* (less 40,001 offset) Read/Write	Appears if"
<u>dEhc</u> [dE.hc]	Derivative Set the PID derivative time in seconds for all outputs.		0.00 to 3,600 seconds (0000 to 3600) 0.00: disabled	0.00	*345, 346 R/W	TRU-TUNE+™ version only. (SD_E - _ _ _ _ _). (<u>hEPr</u>) and/or (<u>CLPr</u>) is set to (<u>PId</u>).
<u>dbhc</u> [db.hc]	Dead Band Set an offset of the proportional band from the set point.		0 to 999 (0000 to 999000)	0	*347, 348 R/W	TRU-TUNE+™ version only. (SD_E - _ _ _ _ _). (<u>hEPr</u>) and/or (<u>CLPr</u>) is set to (<u>PId</u>).
<u>hhys</u> [h.hyS]	Heat Hysteresis Set the control switching hysteresis for on-off control. This determines how far into the "on" region the input needs to move before the output actually turns on.		1 to 999 degrees, if (<u>SEn</u>) is set to (<u>tc</u>) or (<u>rtD</u>) (1000 to 999000) 0.000 to 999.999 units, if (<u>SEn</u>) is set to (<u>PrR</u>) or (<u>uOLt</u>) (0000 to 999999)	1.0 1.000	*232, 233 R/W *234, 235 R/W	At least one output is set to (<u>hERE</u>), and (<u>hEPr</u>) is set to (<u>onof</u>).
<u>CLPr</u> [CL.M]	Cool Control Method Set the Cool Control Method		<u>OFF</u> off (0) <u>PId</u> PID (1) <u>onof</u> on-off (2)	<u>OFF</u> (0)	214 R/W	At least one output is set to (<u>CoOL</u>).
<u>PbCL</u> [Pb.CL]	Proportional Band Cool Set the proportional band for the cool outputs.		1 to 999°F if (<u>SEn</u>) is set to (<u>tc</u>) or (<u>rtD</u>) (1000 to 999000) 0.000 to 999.0 if (<u>SEn</u>) is set to (<u>PrR</u>) or (<u>uOLt</u>) (0000 to 999000)	25 25.000	*337, 338 R/W *341, 342 R/W	At least one output is set to (<u>CoOL</u>), and (<u>CLPr</u>) is set to (<u>PId</u>).
<u>Chys</u> [C.hyS]	Cool Hysteresis Set the control switching hysteresis for on/off control. This determines how far into the "on" region the input needs to move before the output actually turns on.		1 to 999°F if (<u>SEn</u>) is set to (<u>tc</u>) or (<u>rtD</u>) (1000 to 999000) 0.000 to 999.9 if (<u>SEn</u>) is set to (<u>PrR</u>) or (<u>uOLt</u>) (0000 to 999000)	1 1.000	*236, 237 R/W *238, 239 R/W	At least one output is set to (<u>CoOL</u>) and (<u>CLPr</u>) is set to (<u>onof</u>).
<u>PrOP</u> [ProP]	Proportional Term View the active proportional term for PID diagnostics.		0.000 to 1.000**** (0000 to 1000)	NA	258 R	Any output is set to (<u>hERE</u>) or (<u>CoOL</u>).
<u>it</u> [it]	Integral Term View the active integral term for PID diagnostics.		0.000 to 1.000**** (0000 to 1000)	NA	259 R	Any output is set to (<u>hERE</u>) or (<u>CoOL</u>).
<u>dE</u> [dE]	Derivative Term View the active derivative term for PID diagnostics.		0.000 to 1.000**** (0000 to 1000)	NA	260 R	Any output is set to (<u>hERE</u>) or (<u>CoOL</u>).
<u>Alhi</u> [Al.hi]	Alarm 1 High Set the high alarm set point.		Deviation: 0 to 9999 (0000 to 9999000) Process: range of sensor, if (<u>SEn</u>) is set to (<u>tc</u>) or (<u>rtD</u>) -1999 to 9999 if (<u>SEn</u>) is set to (<u>PrR</u>) or (<u>uOLt</u>). (-1999000 to 9999000)	999 (dev) 1500 (pro)	*100, 101 R/W (dev) *104, 105 R/W (pro)	(<u>DEI</u>) is set to (<u>dEARL</u>) or (<u>PrRL</u>).

Note: Parameters appear in the Operations Page only if activated from the programming page. See page 22 for Operations Page defaults.

Note: Some values will be rounded off to fit in the four-character display. Full values can be read with Modbus. All temperature parameters through Modbus are in °F, by default.

* Low register numbers contain the two higher bytes; high register numbers contain the two lower bytes of the four-byte integer. Decimal precision is implied at three decimal places unless otherwise noted.

**** This value multiplied by 100 equals the percent power.

Display	Parameter name Description	Settings	Range	Default	Modbus* (less 40,001 offset) Read/Write	Appears if"
A1Lo [A1.Lo]	Alarm 1 Low Set the low alarm set point.		Deviation: -1999 to 0 (-1999000 to 0000) Process: range of sensor, if SEN is set to tc or rd -1999 to 9999 if SEN is set to PPA or uolt . (-1999000 to 9999000)	-999 (dev) 32 (pro)	*98, 99 R/W (dev) *102, 103 R/W (pro)	DE 1 is set to DEAL or PrAL .
A2Hi [A2.hi]	Alarm 2 High Set the high alarm set point.		Deviation: 0 to 9999 (0000 to 9999000) Process: range of sensor, if SEN is set to tc or rd -1999 to 9999 if SEN is set to PPA or uolt . (-1999000 to 9999000)	999 (dev) 1500 (pro)	*115, 116 R/W (dev) *119, 120 R/W (pro)	DE 2 is set to DEAL or PrAL .
A2Lo [A2.Lo]	Alarm 2 Low Set the low alarm set point.		Deviation: -1999 to 0 (-1999000 to 0000) Process: range of sensor, if SEN is set to tc or rd -1999 to 9999 if SEN is set to PPA or uolt . (-1999000 to 9999000)	-999 (dev) 32 (pro)	*113, 114 R/W (dev) *117, 118 R/W (pro)	DE 2 is set to DEAL or PrAL .
A3Hi [A3.hi]	Alarm 3 High Set the high alarm set point.		Deviation: 0 to 9999 (0000 to 9999000) Process: range of sensor, if SEN is set to tc or rd -1999 to 9999 if SEN is set to PPA or uolt . (-1999000 to 9999000)	999 (dev) 1500 (pro)	*130, 131 R/W (dev) *134, 135 R/W (pro)	DE 3 is set to DEAL or PrAL .
A3Lo [A3.Lo]	Alarm 3 Low Set the low alarm set point.		Deviation: -1999 to 0 (-1999000 to 0000) Process: range of sensor, if SEN is set to tc or rd -1999 to 9999 if SEN is set to PPA or uolt . (-1999000 to 9999000)	-999 (dev) 32 (pro)	*128, 129 R/W (dev) *132, 133 R/W (pro)	DE 3 is set to DEAL or PrAL .

Note: Parameters appear in the Operations Page only if activated from the programming page. See page 22 for Operations Page defaults.



Note: Some values will be rounded off to fit in the four-character display. Full values can be read with Modbus. All temperature parameters through Modbus are in °F, by default.





* Low register numbers contain the two higher bytes; high register numbers contain the two lower bytes of the four-byte integer. Decimal precision is implied at three decimal places unless otherwise noted.

**** This value multiplied by 100 equals the percent power.

8

Chapter 8: Programming Page

The Programming Page allows you to select what parameters appear on the Operations Page. To go to the Programming Page, press both the Advance  and Infinity  keys for six seconds from the Home Page. **Pro9** will appear in the upper display and **PAGE** will appear in the lower display.

- Press the Advance Key  to move through the parameter prompts.
- Press the Up  or Down  key to change the parameter value.
- Press the Infinity Key  at any time to return to the Home Page display.

Note: This chapter only applies to the static set point and profiling versions of the Series SD (SD_C or R - _ _ _ _ - _ _ _).

Display	Parameter name Description	Settings	Range (Integer values for Modbus in parentheses.)	Default	Modbus* (less 40,001 offset) Read/Write	Appears if [†]
P1	Parameter Location 1		none (0) None	PohE (15)	48 R/W	All parameter locations always appear on the Programming Page. Static set point version (SD_C - _ _ _ _ - _ _ _) P1 to P20 Profiling version only. (SD_R - _ _ _ _ - _ _ _) P1 to P23
P2	Parameter Location 2		CRl (1) Calibration Offset	95d (35)	49 R/W	
P3	Parameter Location 3		CF (2) Temperature Units (Setup Page)	RuE (13)	50 R/W	
P4	Parameter Location 4		R1Lo (3) Alarm 1 Low	CRl (1)	51 R/W	
P5	Parameter Location 5		R1Hi (4) Alarm 1 High	hEPT (17)	52 R/W	
P6	Parameter Location 6		R2Lo (5) Alarm 2 Low	PbHE (18)	53 R/W	
P7	Parameter Location 7		R2Hi (6) Alarm 2 High	rEHE (19)	54 R/W	
P8	Parameter Location 8		R3Lo (7) Alarm 3 Low	rRHE (20)	55 R/W	
P9	Parameter Location 9		R3Hi (8) Alarm 3 High	hHY2 (22)	56 R/W	
P10	Parameter Location 10		HY1 (9) Alarm Hysteresis 1 (Setup Page)	CLPT (23)	57 R/W	
P11	Parameter Location 11		HY2 (10) Alarm Hysteresis 2 (Setup Page)	PbCL (24)	58 R/W	
P12	Parameter Location 12		HY3 (11) Alarm Hysteresis 3 (Setup Page)	rECL (25)	59 R/W	
P13	Parameter Location 13		Addr (12) Modbus Device Address (Setup Page)	rRCL (26)	60 R/W	
P14	Parameter Location 14		RuE (13) Autotune	CHYS (28)	61 R/W	
P15	Parameter Location 15		R-M (14) Auto-Manual	R1Hi (4)	62 R/W	
P16	Parameter Location 16		PohE (15) Power Heat	R1Lo (3)	63 R/W	
P17	Parameter Location 17		PoCL (16) Power Cool	R2Hi (6)	64 R/W	
P18	Parameter Location 18		hEPT (17) Heat Control Method	R2Lo (5)	65 R/W	
P19	Parameter Location 19		PbHE (18) Prop. Band Heat	R3Hi (8)	66 R/W	
P20	Parameter Location 20		IEHE (19) Integral Heat or	R3Lo (7)	67 R/W	
P21	Parameter Location 21***		rEHE (19) Reset Heat	Ent1 (32)	68 R/W	
P22	Parameter Location 22***		dEHE (20) Derivative Heat or	Ent2 (33)	69 R/W	
P23	Parameter Location 23***		rRHE (20) Rate Heat	Ent3 (34)	47 R/W	
			dbHE (21) Dead Band Heat			
			hHY5 (22) Heat Hysteresis			
			CLPT (23) Cool Control Method			
			PbCL (24) Prop. Band Cool			
			IECL (25) Integral Cool or			
			rECL (25) Reset Cool			
			dECL (26) Derivative Cool or			
			rRCL (26) Rate Cool			
			dbCL (27) Dead Band Cool			
			CHYS (28) Cool Hysteresis			
			ProP (29) Proportional Term			
			IE (30) Integral Term			
			dE (31) Derivative Term			
			rPE (32) Ramp Rate (Setup Page)**			

Note: All parameter locations have the same range of possible values.

***Static set point version (SD_C - _ _ _ _ - _ _ _)

***Profiling version only. (SD_R - _ _ _ _ - _ _ _)

Programming Page Example





An oven manufacturer wants users of their ovens to have easy access to the Series SD PID parameters. They also want to limit access to other parameters they do not want them to change. This can be achieved by customizing the Operations Page. The Programming Page configuration determines which parameters appear on the Operations Page. The static set point version (SD_C-_-_-_-_-_) has 20 Programming Page locations, P1 to P20. The profiling version (SD_R-_-_-_-_-_) has 23 Programming Page locations, P1 to P23.

The oven manufacturer wants only these parameters to appear on the Operations Page:

- Heat Output Power
- Fahrenheit/Celsius
- Autotune
- Modbus Device Address



To go to the Programming Page, press the Advance  and Infinity  keys for six seconds from the Home Page.

Prog will appear in the upper display and **PAGE** in the lower display.

- Press the Advance Key  to move through the parameter prompts.
- Press the Up  or Down  keys to change the parameter value.
- Press the Infinity Key  at any time to return to the Home Page.



On the Programming Page, select the following settings:





Power **C-F** **Aut** **Addr** **nonE** **nonE**
 P1 **P2** **P3** **P4** **P5** thru **P20**

To access the Operation Page parameters, press the Infinity Key  to return to the Home Page. Press the Advance Key  to see the Operation Page parameters. Only the parameters selected on the Programming Page appear on the Operations Page.

50 **F** **OFF** **I**
Power **C-F** **Aut** **Addr**

9 Chapter 9: Programming Page for TRU-TUNE+™

The Programming Page allows you to select what parameters appear on the Operations Page. To go to the Programming Page, press both the Advance  and Infinity  keys for six seconds from the Home Page. **P_{ro}9** will appear in the upper display and **PAGE** will appear in the lower display.

- Press the Advance Key  to move through the parameter prompts.
- Press the Up  or Down  key to change the parameter value.
- Press the Infinity Key  at any time to return to the Home Page display.

Note: This chapter only applies to the TRU-TUNE+™ version of the Series SD (SD_E - _ _ _ _ - _ _ _ _).

Display	Parameter name Description	Settings	Range (Integer values for Modbus in parentheses.)	Default	Modbus (less 40,001 offset) Read/Write	Appears if'
P1	Parameter Location 1		none (0) None	P_{oh}t (15)	48 R/W	All parameter locations always appear on the Programming Page.
P2	Parameter Location 2		CAL (1) Calibration Offset	R-P₇ (14)	49 R/W	
P3	Parameter Location 3		C-F (2) Temperature Units (Setup Page)	R_ut (13)	50 R/W	
P4	Parameter Location 4		R1Lo (3) Alarm 1 Low	t_un (36)	51 R/W	
P5	Parameter Location 5		R1Hi (4) Alarm 1 High	CAL (1)	52 R/W	
P6	Parameter Location 6		R2Lo (5) Alarm 2 Low	h_tP₇ (17)	53 R/W	
P7	Parameter Location 7		R2Hi (6) Alarm 2 High	P_bh_t (18)	54 R/W	
P8	Parameter Location 8		R3Lo (7) Alarm 3 Low	h_hY₅ (22)	55 R/W	
P9	Parameter Location 9		R3Hi (8) Alarm 3 High	C_LP₇ (23)	56 R/W	
P10	Parameter Location 10		h_Y51 (9) Alarm Hysteresis 1 (Setup Page)	P_bc_L (24)	57 R/W	
P11	Parameter Location 11		h_Y52 (10) Alarm Hysteresis 2 (Setup Page)	C_hY₅ (28)	58 R/W	
P12	Parameter Location 12		h_Y53 (11) Alarm Hysteresis 3 (Setup Page)	i_th_c (19)	59 R/W	
P13	Parameter Location 13		Addr (12) Modbus Device Address (Setup Page)	d_Eh_c (20)	60 R/W	
P14	Parameter Location 14		R_ut (13) Autotune	R1h_i (4)	61 R/W	
P15	Parameter Location 15		R-P₇ (14) Auto-Manual	R1Lo (3)	62 R/W	
P16	Parameter Location 16		P_{oh}t (15) Power Heat	R2h_i (6)	63 R/W	
P17	Parameter Location 17		P_oc_L (16) Power Cool	R2Lo (5)	64 R/W	
P18	Parameter Location 18		h_tP₇ (17) Heat Control Method	R3h_i (8)	65 R/W	
P19	Parameter Location 19		P_bh_t (18) Prop. Band Heat	R3Lo (7)	66 R/W	
P20	Parameter Location 20		i_th_c (19) Integral	none (0)	67 R/W	
			d_Eh_c (20) Derivative			
			db_hc (21) Dead Band			
			h_hY₅ (22) Heat Hysteresis			
			C_LP₇ (23) Cool Control Method			
			P_bc_L (24) Prop. Band Cool			
			C_hY₅ (28) Cool Hysteresis			
			P_ro_P (29) Proportional Term			
			i_t (30) Integral Term			
			d_E (31) Derivative Term			
			r_Pr_t (32) Ramp Rate (Setup Page)			
			(33)			
			(34)			
			(35)			
			t_un (36) TRU-TUNE+™ Enable			



Note: All parameter locations have the same range of possible values.

Programming Page Example





An oven manufacturer wants users of their ovens to have easy access to the Series SD PID parameters. They also want to limit access to other parameters they do not want them to change. This can be achieved by customizing the Operations Page. The Programming Page configuration determines which parameters appear on the Operations Page.

The oven manufacturer wants only these parameters to appear on the Operations Page:

- Heat Output Power
- Fahrenheit/Celsius
- Autotune
- Modbus Device Address



To go to the Programming Page, press the Advance  and Infinity  keys for six seconds from the Home Page.

Prog will appear in the upper display and **PRGE** in the lower display.

- Press the Advance Key  to move through the parameter prompts.
- Press the Up  or Down  keys to change the parameter value.
- Press the Infinity Key  at any time to return to the Home Page.

On the Programming Page, select the following settings:

Power  **Aut Addr**  
     thru 

To access the Operation Page parameters, press the Infinity Key  to return to the Home Page. Press the Advance Key  to see the Operation Page parameters. Only the parameters selected on the Programming Page appear on the Operations Page.

   
Power  **Aut Addr**

10

Chapter 10: Profiling Page

The Profiling Page allows you to enter your ramp and soak profile information. To go to the Profiling Page from the Home Page, press the Advance Key \odot and **PROF** appears in the lower display. Press the Up Key \blacktriangle to change the upper display to **YES**.

- Press the Advance Key \odot to move through the profile parameter prompts.
- Press the Up \blacktriangle or Down \blacktriangledown keys to change the profile parameter values.
- Press the Infinity Key ∞ at any time to return to the Home Page.

Note: The Profiling Page only appears if the profiling version has been ordered (SD_R- ____ - ____).

Note: The Profiling Page is only accessible if the profile is on hold or not running.

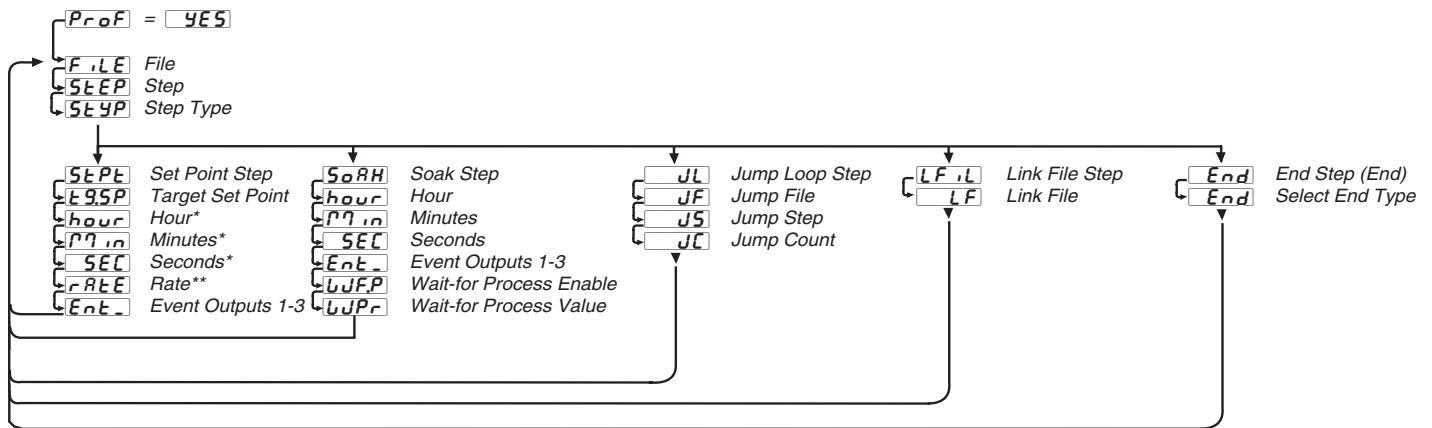

* Hour, minutes and seconds appear if Profile Type **PEYP** is set to **ET**.

** Rate appears if Profile Type **PEYP** is set to **RATE**.

The Profiling Menu

Display	Parameter name Description	Set- tings	Range (Integer values for Mod- bus in parentheses.)	Default	Modbus* (less 40,001 offset) Read/Write	Appears if:
FILE [FiLE]	File Represents the profile to be edited or viewed.		1 (1) 2 (2) 3 (3) 4 (4)	1	See page 53.	Profiling version only. (SD_R - ____ - ____)
STEP [StEP]	Step Represents the current step of the profile to be edited or viewed. Up to ten steps per file.		1 (1) • thru • 10 (10)	1	See page 53.	Profiling version only. (SD_R - ____ - ____)
STYP [StYP]	Step Type Select from five different step types.		End End (0) SEPE Set Point (1) SoRH Soak (2) JL Jump Loop (3) LFIL Link File (4)	End (0)	See page 53.	Profiling version only. (SD_R - ____ - ____)

Note: Some values will be rounded off to fit in the four-character display. Full values can be read with Modbus. All temperature parameters are in °F through Modbus.

* Low register numbers contain the two higher bytes; high register numbers contain the two lower bytes of the four-byte integer. Decimal precision is implied at three decimal places unless otherwise noted.

Display	Parameter name Description	Set- tings	Range (Integer values for Mod- bus in parentheses.)	Default	Modbus* (less 40,001 offset) Read/Write	Appears if:
	[STYP] Set Point Step					
[E9SP] [tg.SP]	Target Set Point Indicates ending set point value the controller ramps to during the set point step.		-1999 to 9999 (-1999000 to 9999000) Target set point values must be between [SPLo] to [SPHi] or step will fail the Pre- Run check and will not run.	75	See page 53.	Profiling version only. (SD_R - - - - - - - -)
[hour] [hour]	Hours The number of hours, (plus Min and Sec parameters) equal the total step time to achieve the ending set point under the [styp] step type.		0 to 99	0	See page 53.	Profiling version only. (SD_R - - - - - - - -) Active if the value set for [PEYP] is [Ei] or time based profiles.
[min] [Min]	Minutes The number of minutes, (plus Hour and Sec parameters) equal the total step time to achieve the ending set point under the [styp] step type.		0 to 59	0	See page 53.	Profiling version only. (SD_R - - - - - - - -) Active if the value set for [PEYP] is [Ei] or time based profiles.
[SEc] [SEc]	Seconds The number of seconds, (plus Hour and Min parameters) equal the total step time to achieve the ending set point under the [STYP] step type.		0 to 59	0	See page 53.	Profiling version only. (SD_R - - - - - - - -) Active if the value set for [PEYP] is [Ei] or time based profiles.
[rAtE] [rAtE]	Rate Indicates rate at which the set point changes in degrees per minute.		0 to 9999	100	See page 53.	Profiling version only. (SD_R - - - - - - - -) Active if the value set for [PEYP] is [rAtE] or rate based profiles.
[Ent1] [Ent1]	Event Output 1 Selects whether Event Output 1 is on or off during the program step.		<input type="checkbox"/> OFF (0) <input type="checkbox"/> On (1)	<input type="checkbox"/> OFF (0)	See page 53.	Profiling version only. (SD_R - - - - - - - -) Output 1 is set to [Ent1] .
[Ent2] [Ent2]	Event Output 2 Selects whether Event Output 2 is on or off during the program step.		<input type="checkbox"/> OFF (0) <input type="checkbox"/> On (1)	<input type="checkbox"/> OFF (0)	See page 53.	Profiling version only. (SD_R - - - - - - - -) Output 2 is set to [Ent2] .
[Ent3] [Ent3]	Event Output 3 Selects whether Event Output 3 is on or off during the program step.		<input type="checkbox"/> OFF (0) <input type="checkbox"/> On (1)	<input type="checkbox"/> OFF (0)	See page 53.	Profiling version only. (SD_R - - - - - - - -) Output 3 is set to [Ent3] .
Note: Some values will be rounded off to fit in the four-character display. Full values can be read with Modbus. All temperature parameters are in °F through Modbus.						
* Low register numbers contain the two higher bytes; high register numbers contain the two lower bytes of the four-byte integer. Decimal precision is implied at three decimal places unless otherwise noted.						

Display	Parameter name Description	Set- tings	Range (Integer values for Mod- bus in parentheses.)	Default	Modbus* (less 40,001 offset) Read/Write	Appears if:
	[SoRH] Soak Step					
[hour] [hour]	Hours The number of hours, (plus Min and Sec parameters) equal the total soak step time at set point under the [SoRH] step type.		0 to 99	0	See page 53.	Profiling version only. (SD_ R - - - - - - - -)
[Min] [Min]	Minutes The number of minutes, (plus Hour and Sec parameters) equal the total soak step time at set point under the [SoRH] step type.		0 to 59	0	See page 53.	Profiling version only. (SD_ R - - - - - - - -)
[SEc] [SEc]	Seconds The number of seconds, (plus Hour and Min parameters) equal the total soak step time at set point under the [SoRH] step type.		0 to 59	0	See page 53.	Profiling version only. (SD_ R - - - - - - - -)
[Ent1] [Ent1]	Event Output 1 Selects whether Event Output 1 is on or off during the program step.		<input type="checkbox"/> OFF (0) <input type="checkbox"/> On (1)	<input type="checkbox"/> OFF (0)	See page 53.	Profiling version only. (SD_ R - - - - - - - -) Output 1 is set to [Ent1] .
[Ent2] [Ent2]	Event Output 2 Selects whether Event Output 2 is on or off during the program step.		<input type="checkbox"/> OFF (0) <input type="checkbox"/> On (1)	<input type="checkbox"/> OFF (0)	See page 53.	Profiling version only. (SD_ R - - - - - - - -) Output 2 is set to [Ent2] .
[Ent3] [Ent3]	Event Output 3 Selects whether Event Output 3 is on or off during the program step.		<input type="checkbox"/> OFF (0) <input type="checkbox"/> On (1)	<input type="checkbox"/> OFF (0)	See page 53.	Profiling version only. (SD_ R - - - - - - - -) Output 3 is set to [Ent3] .
[WFP] [WFP]	Wait-for Process Enable Select to enable Wait-for Process value.		<input type="checkbox"/> no (0) <input type="checkbox"/> YES (1)	<input type="checkbox"/> no (0)	See page 53.	Profiling version only.
[WPr] [WPr]	Wait-for Process Value The program will not begin to decrement the soak time during the programmed step until process value is equal to the Wait-for Process Value setting. Once the Wait-for Process is satisfied, this function is no longer active for this step.		-1999 to 9999 (-1999000 to 9999000)	75	See page 53.	Profiling version only. (SD_ R - - - - - - - -)

Note: Some values will be rounded off to fit in the four-character display. Full values can be read with Modbus. All temperature parameters are in °F through Modbus.

* Low register numbers contain the two higher bytes; high register numbers contain the two lower bytes of the four-byte integer. Decimal precision is implied at three decimal places unless otherwise noted.

Display	Parameter name Description	Set- tings	Range (Integer values for Mod- bus in parentheses.)	Default	Modbus* (less 40,001 offset) Read/Write	Appears if:
	JL Jump Loop Step					
<input type="checkbox"/> JF [JF]	Jump File Selects the file which is to be jumped to. This is a zero-time step.		1 to 4	1	See page 53.	Profiling version only. (SD_ R - - - - - _ _ - - -)
<input type="checkbox"/> JS [JS]	Jump Step Selects the step which is to be jumped to. This is a zero-time step.		1 to 10	1	See page 53.	Profiling version only. (SD_ R - - - - - _ _ - - -)
<input type="checkbox"/> JL [JC]	Jump Count Indicates the number of times the jump is to be done. A value of 0 results in an infinite loop.		0 to 9999	1	See page 53.	Profiling version only. (SD_ R - - - - - _ _ - - -)
	LF , L Link File Step					
<input type="checkbox"/> LF [LF]	Link File Selects the file to link to.		1 to 4	1	See page 53.	Profiling version only. (SD_ R - - - - - _ _ - - -)
	End End Step					
<input type="checkbox"/> End [End]	End Selects the state of the control and auxiliary outputs when a profile is ended.		<input type="checkbox"/> OFF (0) <input type="checkbox"/> hold (1)	<input type="checkbox"/> OFF (0)	See page 53.	Profiling version only. (SD_ R - - - - - _ _ - - -)

Note: Some values will be rounded off to fit in the four-character display. Full values can be read with Modbus. All temperature parameters are in °F through Modbus.

* Low register numbers contain the two higher bytes; high register numbers contain the two lower bytes of the four-byte integer. Decimal precision is implied at three decimal places unless otherwise noted.

How to Navigate the Profiling Menus

	Pre-Run Menu - Profile Off	Pre-Run Menu - Profile Run or Hold	Profile Menu	Run Menu
Menu function	Start a profile.	Holding, resuming or stopping a profile.	Programming a profile.	Viewing profile status.
Enter menu	Press the Infinity Key ☉.	Press the Infinity Key ☉.	Press the Advance Key ☉. At the [Pr o F] prompt, select [Y E S] .	Press the Advance Key ☉.
Scroll through menu	Press the Advance Key ☉.	N/A	Press the Advance Key ☉.	Press the Advance Key ☉.
Change prompt values	Press the Up ▲ or down ▼ key.	Press the Up ▲ or down ▼ key.	Press the Up ▲ or down ▼ key.	Read only.
Exit menu*	Press the Infinity Key ☉ at the [F , I L E] prompt.	Select the desired mode and press the Infinity Key ☉.	Press the Infinity Key ☉.	Press the Infinity Key ☉.
Start profile	Press the Infinity Key ☉ while at the [S E E P] prompt.	N/A	N/A	N/A

Pre-Run Menu**

The Pre-run prompts are only visible when in the Pre-Run mode. The Pre-Run mode is entered by pressing the Infinity Key ☉ one time while at the Home Page. The profile indicator light flashes while in the Pre-Run mode.

The menu consists of the File **[F , I L E]**, Step **[S E E P]** and Select **[S E L C]** prompts. It allows the user to stop or start a profile.

When no profile is running, entering the Pre-run menu allows the selection of a profile and step number to run. Pressing the Advance Key ☉ toggles between the two prompts. Pressing the Infinity Key ☉ at the **[S E E P]** prompt will start the profile. Pressing the Infinity Key ☉ at the **[F , I L E]** prompt will exit the pre-run menu without starting the profile. Pressing the Infinity Key ☉ while a profile is running or on hold will activate the **[S E L C]** prompt. The profile indicator light flashes when **[S E L C]** is displayed. The prompt allows you to choose to hold the profile **[h o l d]**, turn off the profile **[O F F]** or resume running a profile **[r E S U]**.

Pre-Run Menu - Profile off

[F , I L E] File to start profile with

[S E E P] Step to start profile on

Pre-Run Menu - Profile Run or Hold

[h o l d] Hold current profile

[S E L C]

[O F F] Terminate profile

[S E L C]

[r E S U] Resume running current profile

[S E L C]

Note: If there isn't any key press activity for 15 seconds while

in the Pre-Run Menu, the controller exits the Pre-Run Menu and returns to the Home Page.

*Exit menu refers to returning back to the display of process value in the upper display and active set point value in the lower display. The ramping set point will be active while running a profile and the manual adjustable set point will be active when a profile is not running.

**The Lockout parameter in the Setup Page determines your level of access to the other pages and menus, including the Pre-Run and Run menus.

Run Menu*

The Run Menu is active when a program is running. Enter the Run Menu by pressing the Advance Key ☉ once from the Home Page. The profile indicator light will be lit when in the Run Mode. The file-step **[F , S E]** prompt is visible in the Run Menu and shows the current file and step number of the running profile. Other prompts in the Run menu show the target end set point, as well as status for time remaining, ramp rate, wait-for, event status and jump count if relevant.

Run Menu

[F , S E] File number - step number

[E n S P] End set point for step

[h o u r] Hours remaining in step

[M i n] Minutes remaining in step

[S E C] Seconds remaining in step

[r A T E] Ramp rate in minutes for step

[E n t 1] Event Output 1.

[E n t 2] Event Output 2

[E n t 3] Event Output 3

[W J P r] Wait-for process value

[E J C] Elapsed jump count for last jump step

Running a Profile

To run a profile:

1. You must start from the Home Page. Press the Infinity Key ∞ to exit a menu and return to the Home Page. Press the Infinity Key ∞ from the Home Page to enter the Pre-Run menu. The profile light will begin flashing. The lower display will indicate **FILE** and upper display will indicate the file number.
2. Use the Up \blacktriangle or Down \blacktriangledown key to select the desired file number to run. Press the Advance Key \odot . The lower display will indicate **STEP** and the upper display will indicate the step number.
3. Use the Up \blacktriangle or Down \blacktriangledown key to select the desired step number to start the profile on. Press the Infinity Key ∞ to begin the profile. The profile light will go full on.

Profile Errors

If the lower display alternates between a set point and file.step, there is an error in the step. For example, if the display flashes **FILE**, there is a problem with File1, Step 1, and the profile will not run until the problem has been corrected. Check the program step for accuracy.

Holding and Resuming a Profile

If for some reason you need to pause a profile that is running, the profile can be put into a hold mode. While the profile is on hold, you may have full access* to the Setup, Operation and Programming menus to make any required changes. The profile can continue from where it left off using the resume function.

To hold or stop a running profile:

1. You must start from the Home Page. Press the Infinity Key ∞ to exit a menu and return to the Home Page. Press the Infinity Key ∞ to enter the Pre-Run menu. The profile light will begin flashing. **SELC** will appear in the lower display.
2. Use the Up \blacktriangle or Down \blacktriangledown key to select **hold** in the upper display to maintain the present set point and pause the profile. The profile will now be on hold until either **RESU** or **OFF** is selected from the Pre-Run menu. Selecting **OFF** in the upper display will stop the profile and move the set point to **OFF**.

Note: A Pre-Run check verifies that all profile steps are valid before allowing a profile to be started or resumed. A flashing File/Step number in the lower display indicates invalid information in a profile step. See Troubleshooting section.

* The Lockout parameter in the Setup Page determines your level of access to the other pages and menus, including the Pre-Run and Run menus.

To resume a profile on hold:

1. You must start from the Home Page. Press the Infinity Key ∞ to exit a menu and return to the Home Page. Press the Infinity Key ∞ to enter the Pre-Run menu. **SELC** will appear in the lower display.
2. Use the Up \blacktriangle or Down \blacktriangledown key to select **RESU** in the upper display. The profile will continue starting with the step it was running when it was placed on hold.

Editing a Profile on Hold

The profile can be edited* while in the hold mode. If you edit a step that has not yet been executed, the controller will execute that step using the new settings once the profile is resumed. When editing a step that is already in progress, the controller will adjust the current step utilizing the changed settings once the profile is resumed. The step will run as if it was the beginning of the step, including the jump count for a jump step. For example, if you are 3 minutes into a 20 minute step and you change the time, the step starts over at the beginning of the step when the profile is resumed. The new settings will be retained and used in future runs of that profile.

Step Types

Set Point Step

The set point step is used to establish a controller setting within a profile. Set points can be established instantaneously or over some period of time. Establishing a set point over time is also referred to as ramping. The Series SD allows for two methods of expressing a set point ramp, time-based or rate-based. Use the Profile Type **PTYP** parameter on the Setup Page to select the ramp type.

When expressed as time **TIME**, the user enters the target set point and the amount of time desired to increment the current set point towards the target set point. Setting a time of 0 hours, 0 minutes, and 0 seconds causes the set point to be established instantaneously.

When expressed as rate **RATE**, the user enters the target set point and the rate in degrees per minute to increment the current set point towards the target set point. Setting a ramp rate of 0 degrees per minute causes the set point to be established instantaneously. In either time or rate based programming, it is only a manipulation (increment or decrement) of the controller's setting, not the actual process value. To limit set point movement or timing based on the actual process value, use the Guaranteed Soak function and/or the Wait-for Process function of a Soak step.

Soak Step

A Soak step maintains the set point from the previous step for the time in hours, minutes and seconds entered into the step. It is not necessary to enter a set point for this step, only the time duration, the event output states and the Wait-for Process function. The Wait-for function can be enabled or disabled from the Wait-for Process Enable **WJFP** for each individual Soak step. The Wait-for Process function causes the controller to pause the timer until the process value passes through the Wait-for Process value **WJPC**. Once the Wait-for Process value is satisfied, the Wait-for function is not active until the step runs again.

Note: If you have Guaranteed Soak Deviation enabled, the Wait-for Process function is satisfied once the process enters the Guaranteed Soak Deviation window.

* The Lockout parameter in the Setup Page determines your level of access to the other pages and menus, including the Pre-Run and Run menus.

Jump-loop Step

A profile can jump forward or backwards from any step, except Step 1 of any file. You cannot jump-loop to the step that you are on.

Jump-loop example:

Step 1 **SEPE** Set Point Step

Step 2 **SEPE** Set Point Step

Step 3 **SOAH** Soak Step

Step 4 **SEPE** Set Point Step

Step 5 **JL** Jump-loop

JF = 1 **JS** = 2 **JC** = 1

Step 6 **END** End

In this example the program will execute steps 2 through 4 a total of 2 times. This includes the initial pass and the pass associated with the Jump Count of 1. Following the second pass, the End step (Step 6) will be executed and the program will end. The Jump Count can be any number from 0 to 255. If you enter 0, this will be an infinite loop and never progresses to Step 6. When Jump File is not set to the current program file, the profile may jump to any step of any programmed files.

Link File Step

The Link File step enables you to link any step other than the first step of a profile to the first step of another profile. Linking profiles allows for a simple method to effectively extend the number of steps available in a profile. All four profiles of the Series SD can be linked together to effectively give you a profile with 40 steps. However, each link step consumes one of the available profile steps and Step 10 of each profile is an End step. If you link File 1 to File 2, File 2 to File 3 and File 3 to File 4, only 34 steps would be available to perform the actual functions of a user's profile. In this example, linking the last profile to the first profile causes the profile to run endlessly.

End Step

The End step ends the profile and selects the status of the control set point and event outputs when a profile finishes. When Hold **hold** is selected, the control set point and event outputs maintain the same state they were in before the End step was executed. When selected as Off **OFF**, the control set point will be set to off (control outputs off) and any event outputs will be set to the off state.

Event Outputs

The flexibility of the Series SD allows configuration of any available output as an event output. An event output is simply an output that can be turned on or off through a profile step, or manually from the front panel if a profile is not running. The event may turn any number of peripheral devices on or off to assist you in controlling your process or system. For instance, an environmental chamber might need to energize a fan to circulate air at a given time in your profile for one or more steps. The chamber might need to turn lights on or off, lock out the humidification system or activate a video recorder. Each output can be configured as an event output on the Setup Page. Once configured, the option to set an event output's state appears while programming the steps in a profile. The state can be selected as on or off for each set point step and soak step in the profile.

Guaranteed Soak

The Guaranteed Soak Deviation feature insures that the actual temperature tracks a programmed profile within a window around set point. See figure below. If the deviation value from set point is exceeded, the timer function pauses, and the lower display alternately flashes between **95d** and the current parameter until the process variable returns within the deviation window. Setting **95dE** to **YES** enables the Guaranteed Soak Deviation function. When enabled, it applies to all steps within the profiles. Programmed in degrees or units, the value entered for Guaranteed Soak Deviation sets up a plus and minus deviation around the set point. **95dE** and **95d** are located on the Setup Page. The **95d** parameter can also be added to the Operation's Page.

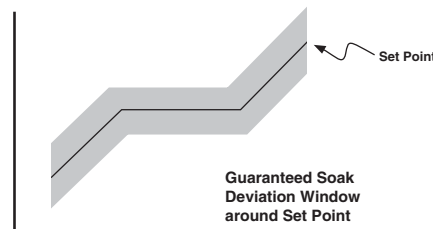

Note: If you have Guaranteed Soak Deviation enabled, the Wait-for Process function is satisfied once the process enters the Guaranteed Soak Deviation window.

Example profile

Gwen, of Smith Manufacturing needs to perform a burn-in test of their product in an environmental chamber. The test should take the product through the following sequence:

1. Heat from room temperature to a temperature of 150°F over a 1-hour period.
2. Hold the temperature at 150°F for 2 hours.
3. Cool the temperature to 32°F as quickly as possible.
4. Once the temperature reaches 32°F, hold that temperature for 2 hours.
5. Stop controlling the temperature and allow it to return to room temperature naturally.

Use the master step chart to map out the profile.

Circle File Number: 1 2 3 4				Master Step Chart					
Step 1	___ S tp (Ptyp=ti) Tg.SP 150 Hour 1 Min. 0 Sec. 0 Ent1: On Off Ent2: On Off Ent3: On Off								
	___ Stpt (Ptyp=rate) Tg.SP Rate Ent1: On Off Ent2: On Off Ent3: On Off								
	___ Soak Hour Min. Sec. Ent1: On Off Ent2: On Off Ent3: On Off W.F.P: Yes No W.Pr								
	___ JL JF JS JC								
	___ LFil LF								
	___ End End: Off Hold								
Step 2	___ Stpt (Ptyp=ti) Tg.SP Hour Min Sec. Ent1: On Off. Ent2: On Off Ent3: On Off								
	___ Stpt (Ptyp=rate) Tg.SP Rate Ent1: On Off Ent2: On Off Ent3: On Off								
	___ S tp Hour 2 Min. 0 Sec. 0 Ent1: On Off Ent2: On Off Ent3: On Off W.F.P: Yes No W.Pr								
	___ JL JF JS JC								
	___ LFil LF								
	___ End End: Off Hold								
Step 3	___ S tp (Ptyp=ti) Tg.SP 32 Hour 0 Min. 0 Sec. 0 Ent1: On Off Ent2: On Off Ent3: On Off								
	___ Stpt (Ptyp=rate) Tg.SP Rate Ent1: On Off Ent2: On Off Ent3: On Off								
	___ Soak Hour Min. Sec. Ent1: On Off Ent2: On Off Ent3: On Off W.F.P: Yes No W.Pr								
	___ JL JF JS JC								
	___ LFil LF								
	___ End End: Off Hold								
Step 4	___ Stpt (Ptyp=ti) Tg.SP Hour Min Sec Ent1: On Off. Ent2: On Off Ent3: On Off								
	___ Stpt (Ptyp=rate) Tg.SP Rate Ent1: On Off Ent2: On Off Ent3: On Off								
	___ S tp Hour 2 Min. 0 Sec. 0 Ent1: On Off Ent2: On Off Ent3: On Off W.F.P: Yes No W.Pr 32								
	___ JL JF JS JC								
	___ LFil LF								
	___ End End: Off Hold								
Step 5	___ Stpt (Ptyp=ti) Tg.SP Hour Min. Sec. Ent1: On Off Ent2: On Off Ent3: On Off								
	___ Stpt (Ptyp=rate) Tg.SP Rate Ent1: On Off Ent2: On Off Ent3: On Off								
	___ Soak Hour Min. Sec. Ent1: On Off Ent2: On Off Ent3: On Off W.F.P: Yes No W.Pr								
	___ JL JF JS JC								
	___ LFil LF								
	___ E nd End: Off Hold								

Step 1	<input type="text" value="1"/>	<input type="text" value="1"/>	<input type="text" value="SETE"/>	<input type="text" value="150"/>	<input type="text" value="1"/>	<input type="text" value="0"/>	<input type="text" value="0"/>	
	FILE	STEP	SEYP	TEMP	hour	min	SEC	
Step 2	<input type="text" value="1"/>	<input type="text" value="2"/>	<input type="text" value="Soak"/>	<input type="text" value="2"/>	<input type="text" value="0"/>	<input type="text" value="0"/>	<input type="text" value="no"/>	
	FILE	STEP	SEYP	hour	min	SEC	WJFP	
Step 3	<input type="text" value="1"/>	<input type="text" value="3"/>	<input type="text" value="SETE"/>	<input type="text" value="32"/>	<input type="text" value="0"/>	<input type="text" value="0"/>	<input type="text" value="0"/>	
	FILE	STEP	SEYP	TEMP	hour	min	SEC	
Step 4	<input type="text" value="1"/>	<input type="text" value="4"/>	<input type="text" value="Soak"/>	<input type="text" value="2"/>	<input type="text" value="0"/>	<input type="text" value="0"/>	<input type="text" value="YES"/>	<input type="text" value="32"/>
	FILE	STEP	SEYP	hour	min	SEC	WJFP	WJPr
Step 5	<input type="text" value="1"/>	<input type="text" value="5"/>	<input type="text" value="End"/>	<input type="text" value="OFF"/>				
	FILE	STEP	SEYP	End				

Circle File Number: 1 2 3 4				Master Step Chart (Make a copy and write in your settings)					
Step 1	___ Stpt (Ptyp=ti)	Tg.	Hou	Min.	Sec.	Ent1: On Off	Ent2: On Off	Ent3: On Off	
	___ Stpt (Ptyp=rate)	Tg.SP	Rate	Ent1: On Off	Ent2: On Off	Ent3: On Off			
	___ Soak	Hour	Min.	Sec.	Ent1: On Off	Ent2: On Off	Ent3: On Off	W.F.P: Yes No	W.Pr
	___ JL	JF	JS	JC					
	___ LFil	LF							
	___ End	End: Off Hold							
Step 2	___ Stpt (Ptyp=ti)	Tg.SP	Hour	Min	Sec.	Ent1: On Off.	Ent2: On Off	Ent3: On Off	
	___ Stpt (Ptyp=rate)	Tg.SP	Rate	Ent1: On Off	Ent2: On Off	Ent3: On Off			
	___ Soak	Hour	Min. 0	Sec. 0	Ent1: On Off	Ent2: On Off	Ent3: On Off	W.F.P Yes No	WPr
	___ JL	JF	JS	JC					
	___ LFil	LF							
	___ End	End: Off Hold							
Step 3	___ Stpt (Ptyp=ti)	Tg.SP	Hour 0	Min. 0	Sec. 0	Ent1: On Off	Ent2: On Off	Ent3: On Off	
	___ Stpt (Ptyp=rate)	Tg.SP	Rate	Ent1: On Off	Ent2: On Off	Ent3: On Off			
	___ Soak	Hour	Min.	Sec.	Ent1: On Off	Ent2: On Off	Ent3: On Off	W.F.P Yes No	WPr
	___ JL	JF	JS	JC					
	___ LFil	LF							
	___ End	End: Off Hold							
Step 4	___ Stpt (Ptyp=ti)	Tg.SP	Hour	Min	Sec	Ent1: On Off.	Ent2: On Off	Ent3: On Off	
	___ Stpt (Ptyp=rate)	Tg.SP	Rate	Ent1: On Off	Ent2: On Off	Ent3: On Off			
	___ Soak	Hour	Min. 0	Sec. 0	Ent1: On Off	Ent2: On Off	Ent3: On Off	W.F.P Yes No	WPr
	___ JL	JF	JS	JC					
	___ LFil	LF							
	___ End	End: Off Hold							
Step 5	___ Stpt (Ptyp=ti)	Tg.SP	Hour	Min.	Sec.	Ent1: On Off	Ent2: On Off	Ent3: On Off	
	___ Stpt (Ptyp=rate)	Tg.SP	Rate	Ent1: On Off	Ent2: On Off	Ent3: On Off			
	___ Soak	Hour	Min.	Sec.	Ent1: On Off	Ent2: On Off	Ent3: On Off	W.F.P Yes No	WPr
	___ JL	JF	JS	JC					
	___ LFil	LF							
	___ End	End: Off Hold							
Step 6	___ Stpt (Ptyp=ti)	Tg.SP	Hour	Min.	Sec.	Ent1: On Off	Ent2: On Off	Ent3: On Off	
	___ Stpt (Ptyp=rate)	Tg.SP	Rate	Ent1: On Off	Ent2: On Off	Ent3: On Off			
	___ Soak	Hour	Min.	Sec.	Ent1: On Off	Ent2: On Off	Ent3: On Off	W.F.P Yes No	WPr
	___ JL	JF	JS	JC					
	___ LFil	LF							
	___ End	End: Off Hold							
Step 7	___ Stpt (Ptyp=ti)	Tg.SP	Hour	Min.	Sec.	Ent1: On Off	Ent2: On Off	Ent3: On Off	
	___ Stpt (Ptyp=rate)	Tg.SP	Rate	Ent1: On Off	Ent2: On Off	Ent3: On Off			
	___ Soak	Hour	Min.	Sec.	Ent1: On Off	Ent2: On Off	Ent3: On Off	W.F.P: Yes No	W.Pr
	___ JL	JF	JS	JC					
	___ LFil	LF							
	___ End	End: Off Hold							
Step 8	___ Stpt (Ptyp=ti)	Tg.SP	Hour	Min.	Sec.	Ent1: On Off	Ent2: On Off	Ent3: On Off	
	___ Stpt (Ptyp=rate)	Tg.SP	Rate	Ent1: On Off	Ent2: On Off	Ent3: On Off			
	___ Soak	Hour	Min.	Sec.	Ent1: On Off	Ent2: On Off	Ent3: On Off	W.F.P: Yes No	W.Pr
	___ JL	JF	JS	JC					
	___ LFil	LF							
	___ End	End: Off Hold							
Step 9	___ Stpt (Ptyp=ti)	Tg.SP	Hour	Min.	Sec.	Ent1: On Off	Ent2: On Off	Ent3: On Off	
	___ Stpt (Ptyp=rate)	Tg.SP	Rate	Ent1: On Off	Ent2: On Off	Ent3: On Off			
	___ Soak	Hour	Min.	Sec.	Ent1: On Off	Ent2: On Off	Ent3: On Off	W.F.P: Yes No	W.Pr
	___ JL	JF	JS	JC					
	___ LFil	LF							
	___ End	End: Off Hold							
Step 10									
	___ End	End: Off Hold	Note: Step 10 in each file can only be an End Step.						

Series SD Profiling Modbus Registers

This section contains information for creating, editing and running profiles using Modbus. Some of these are available only through Modbus and others can be accessed through the front panel and Modbus. If a parameter is accessible only through Modbus, N/A appears in the display column. Parameters appear in profiling version only.

Display	Parameter Name Description	Settings	Range (Integer values for Modbus in parentheses.)	Default	Modbus* (less 40,001 offset) Read/Write	Appears if:
[PEYP] [Ptyp]	Profile Type Set the profile ramp to time based or rate based.		[t,] Time based ramp (0) [RtE] Rate based ramp (1)	[t,] (0)	354 R/W	Always
[PStr] [PStr]	Profile Start Select where the profile begins the starting set point of the profile, current static set point or current process temperature.		[SE] Static Set Point (0) [Pro] Process (1)	[SE] (0)	355 R/W	Always
[gS.dE] [gS.dE]	Guaranteed Soak Deviation Enable Enables the guaranteed soak deviation function in profiles.		[no] Disabled (0) [yES] Enabled (1)	[no] (0)	356 R/W	Always
[gSd] [gSd]	Guaranteed Soak Deviation Value Set the value of deviation allowed by the guaranteed soak deviation function.		1 to 999 (1 to 999000)	1	*357, 358 R/W	[gS.dE] set to [yES]
N/A	Profile State Indicates current profile status.		Profile off (0) Profile is holding (1) Profile is running (2) Pre-run check failed when starting the profile (3) Pre-run check failed when resuming the profile (4)	0	359 R	Available through Modbus only.
N/A	Jump Count Step Enabled Indicates whether a Jump Step is currently being executed.		Profile is not running or profile is running and is not currently executing a Jump Step (0) Profile is running and the profile is currently executing a Jump Step (1)	0	363 R	Available through Modbus only.
[FiLE] [FiLE]	Start File Number Selects the file to start running.		1 to 4	1	361 R/W	Always
[StEP] [StEP]	Start Step Number Selects the profile step to be run.		1 to 10	1	362 R/W	Always
[SELC] [SELC]	Profile Select Selects what to do when a profile is on hold.		[OFF] Terminate current profile (0) [RESU] Resume running current profile (1) [hold] Hold current profile (2)		360 R/W	If profile is holding or running.
[GSD] [GSD]	Guaranteed Soak Deviation Message Monitors guaranteed soak deviation status.		Message Disabled [GSD is disabled or within range if enabled. No message is flashing] (0) Message Enabled [GSD outside range and a message is flashing] (1)	0	364 R	[gS.dE] set to [yES]

Note: Some values will be rounded off to fit in the four-character display. Full values can be read with Modbus. All temperature parameters are in °F through Modbus.

* Low register numbers contain the two higher bytes; high register numbers contain the two lower bytes of the four-byte integer. Decimal precision is implied at three decimal places unless otherwise noted.

Monitoring Profile Status from Modbus

Display	Parameter Name Description	Settings	Range (Integer values for Modbus in parentheses.)	Default	Modbus* (less 40,001 offset) Read/Write	Appears if:
N/A	File Running File number that is currently running.		1 to 4	1	900 R	Profile is running.
N/A	Step Running Step number that is currently running.		1 to 10	1	901 R	Profile is running.
EnSP [EnSP]	End Set Point Value Set point value reached at the end of the current step.		SPLo to SPHi		*902, 903 R	Profile is running.
hour [hour]	Hours Remaining Indicates number of hours remaining in the step currently running.		0 to 99		904 R	Profile is running. Active if the value set for PEYP is E , or time based profiles.
Min [-Min]	Minutes Remaining Indicates number of minutes remaining in the step currently running.		0 to 59		905 R	Profile is running. Active if the value set for PEYP is E , or time based profiles.
SEC [SEc]	Seconds Remaining Indicates number of seconds remaining in the step currently running.		0 to 59		907 R	Profile is running. Active if the value set for PEYP is E , or time based profiles.
rAtE [rAtE]	Ramp Rate Rate at which the profile changes in degrees or units per minute.		0.0 to 9999.9 (0 to 9999900)		*907, 908 R	Profile is running. Active if the value set for PEYP is rAtE or rate based profiles.
Ent1 [Ent1]	Event Output 1 status Indicates Event Output 1 status.		OFF (0) On (1)		909 R	Profile is running. Output 1 is set to Ent1 .
Ent2 [Ent2]	Event Output 2 status Indicates Event Output 2 status.		OFF (0) On (1)		910 R	Profile is running. Output 2 is set to Ent2 .
Ent3 [Ent3]	Event Output 3 status Indicates Event Output 3 status.		OFF (0) On (1)		911 R	Profile is running. Output 3 is set to Ent3 .
WJPr [WPr]	Wait-for Process Value Profile clock waits until the process value matches the Wait-for value and then continues with the step.		SPLo to SPHi		*912, 913 R	Profile is running. WJPr set to YES .
EJC [EJC]	Elapsed Jump Count Number of times the profile has been through the Jump Loop Step.		0 to 9999 (0 to 9999000)		914 R	Profile is running and the current profile step running is a Jump Loop Step Type.
N/A	Failed File Number Indicates the file number that failed the Pre-Run check.		1 to 4		365 R	Profile State is set to 3 (Pre-Run Failed Start) or 4 (Pre-Run Failed Resume)
N/A	Failed Step Number Indicates the step number that failed the Pre-Run check.		1 to 10		366 R	Profile State is set to 3 (Pre-Run Failed Start) or 4 (Pre-Run Failed Resume)

Note: Some values will be rounded off to fit in the four-character display. Full values can be read with Modbus. All temperature parameters are in °F through Modbus.

* Low register numbers contain the two higher bytes; high register numbers contain the two lower bytes of the four-byte integer. Decimal precision is implied at three decimal places unless otherwise noted.

Series SD Profiling Modbus Register Numbers

This table contains the Modbus register numbers. The number in () identifies the file number for that register.





Parameter	File (X) Step 1	File (X) Step 2	File (X) Step 3	File (X) Step 4	File (X) Step 5	File (X) Step 6	File (X) Step 7	File (X) Step 8	File (X) Step 9	File (X) Step 10
Step Type	1000 (1) 1250 (2) 1500 (3) 1750 (4)	1025 (1) 1275 (2) 1525 (3) 1775 (4)	1050 (1) 1300 (2) 1550 (3) 1800 (4)	1075 (1) 1325 (2) 1575 (3) 1825 (4)	1100 (1) 1350 (2) 1600 (3) 1850 (4)	1125 (1) 1375 (2) 1625 (3) 1875 (4)	1150 (1) 1400 (2) 1650 (3) 1900 (4)	1175 (1) 1425 (2) 1675 (3) 1925 (4)	1200 (1) 1450 (2) 1700 (3) 1950 (4)	
Target Set Point (two registers)	1001 (1) 1251 (2) 1501 (3) 1751 (4)	1026 (1) 1276 (2) 1526 (3) 1776 (4)	1051 (1) 1301 (2) 1551 (3) 1801 (4)	1076 (1) 1326 (2) 1576 (3) 1826 (4)	1101 (1) 1351 (2) 1601 (3) 1851 (4)	1126 (1) 1376 (2) 1626 (3) 1876 (4)	1151 (1) 1401 (2) 1651 (3) 1901 (4)	1176 (1) 1426 (2) 1676 (3) 1926 (4)	1201 (1) 1451 (2) 1701 (3) 1951 (4)	
Hours	1003 (1) 1253 (2) 1503 (3) 1753 (4)	1028 (1) 1278 (2) 1528 (3) 1778 (4)	1053 (1) 1303 (2) 1553 (3) 1803 (4)	1078 (1) 1328 (2) 1578 (3) 1828 (4)	1103 (1) 1353 (2) 1603 (3) 1853 (4)	1128 (1) 1378 (2) 1628 (3) 1878 (4)	1153 (1) 1403 (2) 1653 (3) 1903 (4)	1178 (1) 1428 (2) 1678 (3) 1928 (4)	1203 (1) 1453 (2) 1703 (3) 1953 (4)	
Minutes	1004 (1) 1254 (2) 1504 (3) 1754 (4)	1029 (1) 1279 (2) 1529 (3) 1779 (4)	1054 (1) 1304 (2) 1554 (3) 1804 (4)	1079 (1) 1329 (2) 1579 (3) 1829 (4)	1104 (1) 1354 (2) 1604 (3) 1854 (4)	1129 (1) 1379 (2) 1629 (3) 1879 (4)	1154 (1) 1404 (2) 1654 (3) 1904 (4)	1179 (1) 1429 (2) 1679 (3) 1929 (4)	1204 (1) 1454 (2) 1704 (3) 1954 (4)	
Seconds	1005 (1) 1255 (2) 1505 (3) 1755 (4)	1030 (1) 1280 (2) 1530 (3) 1780 (4)	1055 (1) 1305 (2) 1555 (3) 1805 (4)	1080 (1) 1330 (2) 1580 (3) 1830 (4)	1105 (1) 1355 (2) 1605 (3) 1855 (4)	1130 (1) 1380 (2) 1630 (3) 1880 (4)	1155 (1) 1405 (2) 1655 (3) 1905 (4)	1180 (1) 1430 (2) 1680 (3) 1930 (4)	1205 (1) 1455 (2) 1705 (3) 1955 (4)	
Ramp Rate (two registers)	1006 (1) 1256 (2) 1506 (3) 1756 (4)	1031 (1) 1281 (2) 1531 (3) 1781 (4)	1056 (1) 1306 (2) 1556 (3) 1806 (4)	1081 (1) 1331 (2) 1581 (3) 1831 (4)	1106 (1) 1356 (2) 1606 (3) 1856 (4)	1131 (1) 1381 (2) 1631 (3) 1881 (4)	1156 (1) 1406 (2) 1656 (3) 1906 (4)	1181 (1) 1431 (2) 1681 (3) 1931 (4)	1206 (1) 1456 (2) 1706 (3) 1956 (4)	
Event Output 1	1008 (1) 1258 (2) 1508 (3) 1758 (4)	1033 (1) 1283 (2) 1533 (3) 1783 (4)	1058 (1) 1308 (2) 1558 (3) 1808 (4)	1083 (1) 1333 (2) 1583 (3) 1833 (4)	1108 (1) 1358 (2) 1608 (3) 1858 (4)	1133 (1) 1383 (2) 1633 (3) 1883 (4)	1158 (1) 1408 (2) 1658 (3) 1908 (4)	1183 (1) 1433 (2) 1683 (3) 1933 (4)	1208 (1) 1458 (2) 1708 (3) 1958 (4)	
Event Output 2	1009 (1) 1259 (2) 1509 (3) 1759 (4)	1034 (1) 1284 (2) 1534 (3) 1784 (4)	1059 (1) 1309 (2) 1559 (3) 1809 (4)	1084 (1) 1334 (2) 1584 (3) 1834 (4)	1109 (1) 1359 (2) 1609 (3) 1859 (4)	1134 (1) 1384 (2) 1634 (3) 1884 (4)	1159 (1) 1409 (2) 1659 (3) 1909 (4)	1184 (1) 1434 (2) 1684 (3) 1934 (4)	1209 (1) 1459 (2) 1709 (3) 1959 (4)	
Event Output 3	1010 (1) 1260 (2) 1510 (3) 1760 (4)	1035 (1) 1285 (2) 1535 (3) 1785 (4)	1060 (1) 1310 (2) 1560 (3) 1810 (4)	1085 (1) 1335 (2) 1585 (3) 1835 (4)	1110 (1) 1360 (2) 1610 (3) 1860 (4)	1135 (1) 1385 (2) 1635 (3) 1885 (4)	1160 (1) 1410 (2) 1660 (3) 1910 (4)	1185 (1) 1435 (2) 1685 (3) 1935 (4)	1210 (1) 1460 (2) 1710 (3) 1960 (4)	
Wait-for Process Enable	1011 (1) 1261 (2) 1511 (3) 1761 (4)	1036 (1) 1286 (2) 1536 (3) 1786 (4)	1061 (1) 1311 (2) 1561 (3) 1811 (4)	1086 (1) 1336 (2) 1586 (3) 1836 (4)	1111 (1) 1361 (2) 1611 (3) 1861 (4)	1136 (1) 1386 (2) 1636 (3) 1886 (4)	1161 (1) 1411 (2) 1661 (3) 1911 (4)	1186 (1) 1436 (2) 1686 (3) 1936 (4)	1211 (1) 1461 (2) 1711 (3) 1961 (4)	
Wait-for Process Value (two registers)	1012 (1) 1262 (2) 1512 (3) 1762 (4)	1037 (1) 1287 (2) 1537 (3) 1787 (4)	1062 (1) 1312 (2) 1562 (3) 1812 (4)	1087 (1) 1337 (2) 1587 (3) 1837 (4)	1112 (1) 1362 (2) 1612 (3) 1862 (4)	1137 (1) 1387 (2) 1637 (3) 1887 (4)	1162 (1) 1412 (2) 1662 (3) 1912 (4)	1187 (1) 1437 (2) 1687 (3) 1937 (4)	1212 (1) 1462 (2) 1712 (3) 1962 (4)	
Jump File	1014 (1) 1264 (2) 1514 (3) 1764 (4)	1039 (1) 1289 (2) 1539 (3) 1789 (4)	1064 (1) 1314 (2) 1564 (3) 1814 (4)	1089 (1) 1339 (2) 1589 (3) 1839 (4)	1114 (1) 1364 (2) 1614 (3) 1864 (4)	1139 (1) 1389 (2) 1639 (3) 1889 (4)	1164 (1) 1414 (2) 1664 (3) 1914 (4)	1189 (1) 1439 (2) 1689 (3) 1939 (4)	1214 (1) 1464 (2) 1714 (3) 1964 (4)	
Jump Step	1014 (1) 1264 (2) 1514 (3) 1764 (4)	1040 (1) 1290 (2) 1540 (3) 1790 (4)	1065 (1) 1315 (2) 1565 (3) 1815 (4)	1090 (1) 1340 (2) 1590 (3) 1840 (4)	1115 (1) 1365 (2) 1615 (3) 1865 (4)	1140 (1) 1390 (2) 1640 (3) 1890 (4)	1165 (1) 1415 (2) 1665 (3) 1915 (4)	1190 (1) 1440 (2) 1690 (3) 1940 (4)	1215 (1) 1465 (2) 1715 (3) 1965 (4)	
Jump Count	1016 (1) 1266 (2) 1516 (3) 1766 (4)	1041 (1) 1291 (2) 1541 (3) 1791 (4)	1066 (1) 1316 (2) 1566 (3) 1816 (4)	1091 (1) 1341 (2) 1591 (3) 1841 (4)	1116 (1) 1366 (2) 1616 (3) 1866 (4)	1141 (1) 1391 (2) 1641 (3) 1891 (4)	1166 (1) 1416 (2) 1666 (3) 1916 (4)	1191 (1) 1441 (2) 1691 (3) 1941 (4)	1216 (1) 1466 (2) 1716 (3) 1966 (4)	
Link File	1017 (1) 1267 (2) 1517 (3) 1767 (4)	1042 (1) 1292 (2) 1542 (3) 1792 (4)	1067 (1) 1317 (2) 1567 (3) 1817 (4)	1092 (1) 1342 (2) 1592 (3) 1842 (4)	1117 (1) 1367 (2) 1617 (3) 1867 (4)	1142 (1) 1392 (2) 1642 (3) 1892 (4)	1167 (1) 1417 (2) 1667 (3) 1917 (4)	1192 (1) 1442 (2) 1692 (3) 1942 (4)	1217 (1) 1467 (2) 1717 (3) 1967 (4)	
End Step	1018 (1) 1268 (2) 1518 (3) 1768 (4)	1043 (1) 1293 (2) 1543 (3) 1793 (4)	1068 (1) 1318 (2) 1568 (3) 1818 (4)	1093 (1) 1343 (2) 1593 (3) 1843 (4)	1118 (1) 1368 (2) 1618 (3) 1868 (4)	1143 (1) 1393 (2) 1643 (3) 1893 (4)	1168 (1) 1418 (2) 1668 (3) 1918 (4)	1193 (1) 1443 (2) 1693 (3) 1943 (4)	1218 (1) 1468 (2) 1718 (3) 1968 (4)	1243 (3) 1493 (2) 1743 (3) 1993 (4)

Low register numbers contain the two higher bytes; high register numbers contain the two lower bytes of the four-byte integer. Decimal precision is implied at three decimal places unless otherwise noted. All temperature parameters are in °F through Modbus.

11

Chapter 11: Factory Page





To go to the Factory Page, press both the Up  and Down  keys for six seconds from the Home Page. **[FACT]** will appear in the upper display and **[PAGE]** in the lower display.

- Press the Advance Key  to move through the parameter prompts.
- Press the Up  or Down  keys to change the parameter value.
- Press the Infinity Key  at any time to return to the Home Page.

Display	Parameter Name Description	Settings	Range (Integer values for Modbus in parentheses.)	Default	Modbus* (less 40,001 offset) Read/Write	Appears if:
[AMB] [AMb]	Ambient Temperature Displays the current calculated ambient temperature.		-50.0 to 300.0°F	NA		Always active.
[A.Mn] [A.Mn]	Minimum Recorded Ambient Temperature Displays the minimum recorded ambient temperature.		-50.0 to 300.0°F	NA	NA	Always active.
[A.MA] [A.MA]	Maximum Recorded Ambient Temperature Displays the maximum recorded ambient temperature.		-50.0 to 300.0°F	NA	NA	Always active.
[dSPL] [dSPL]	Display Intensity Increase or decrease the brightness of the upper and lower display.		15 to 100% duty	100	NA	Always active.
[rESt] [rESt]	Restore Factory Calibration Replaces the user calibration parameters with the factory calibration parameters.		<input type="checkbox"/> no (0) <input type="checkbox"/> YES (1)	<input type="checkbox"/> no (0)	208 R/W	Always active.
[Usr.r] [Usr.r]	Restore User Settings Restores customer configured settings. Two sets of user settings for non-profiling version and one set of user settings for profiling version.		<input type="checkbox"/> no (0) <input type="checkbox"/> SEt 1 (1) <input type="checkbox"/> SEt 2 (2) <input type="checkbox"/> no (0) <input type="checkbox"/> YES (1)	<input type="checkbox"/> no (0)	209 R/W	Non-profiling version only. (SD_C - _ _ _ _ - _ _ _) Profiling version only. (SD_R - _ _ _ _ - _ _ _)
[USr.S] [USr.S]	Save User Settings Saves customer configured settings. Two sets of user settings for non-profiling version and one set of user settings for profiling version.		<input type="checkbox"/> no (0) <input type="checkbox"/> SEt 1 (1) <input type="checkbox"/> SEt 2 (2) <input type="checkbox"/> no (0) <input type="checkbox"/> YES (1)	<input type="checkbox"/> no (0)	210 R/W	Non-profiling version only. (SD_C - _ _ _ _ - _ _ _) Profiling version only. (SD_R - _ _ _ _ - _ _ _)
[PrFr] [PrFr]	Restore User Profiles Restores the current customer configured profiles		<input type="checkbox"/> no (0) <input type="checkbox"/> YES (1)	<input type="checkbox"/> no (0)	209 R/W	Profiling version only. (SD_R - _ _ _ _ - _ _ _)
[Prf.S] [Prf.S]	Save User Profiles Saves the current customer configured profiles.		<input type="checkbox"/> no (0) <input type="checkbox"/> YES (1)	<input type="checkbox"/> no (0)	210 R/W	Profiling version only. (SD_R - _ _ _ _ - _ _ _).
[dFLt] [dFLt]	Default Parameters Reset all parameters to the default values (may take up to 4 seconds to complete).		<input type="checkbox"/> no (0) <input type="checkbox"/> YES (1)	<input type="checkbox"/> no (0)	207 R/W	Always active.

Display	Parameter Name Description	Settings	Range (Integer values for Modbus in parentheses.)	Default	Modbus* (less 40,001 offset) Read/Write	Appears if:
0EY1 [O.ty1]	Output 1 Type Displays the hardware type for Output 1.		none none (0) dc DC/open collect. (1) RLAY mech. relay (2) SSr solid-state relay (3) Proc process (4)	none none (0)	202 R	Always active.
0EY2 [O.ty2]	Output 2 Type Displays the hardware type for Output 2.		none none (0) dc DC/open collect. (1) RLAY mech. relay (2) SSr solid-state relay (3) COMM communications (5)	none none (0)	203 R	Always active.
0EY3 [O.ty3]	Output 3 Type Displays the hardware type for Output 3.		none none (0) dc DC/open collect. (1) RLAY mech. relay (2) SSr solid-state relay (3) Proc process (4)	none none (0)	204 R	Always active.
S.id [S.id]	Software ID Displays the software ID number.		0 to 9999	NA	10 R	Always active.
S.VEr [S.VEr]	Software Version Displays the firmware revision.		0.00 to 99.99	NA	11 R	Always active.
S.bLd [S.bLd]	Software Build Number Displays the software build number.		0 to 9999 Build Number	NA	13 R	Always active.
PWjr [PWr]	Power Type Displays the type of input power.		HL high voltage LOLJ low voltage	NA	*NA	Always active.
Sn- [Sn-]	Serial Number 1 Displays the first four characters of the serial number.		0 to 9999	NA	7,8 R	Always active.
Sn_ [Sn_]	Serial Number 2 Displays the last four characters of the serial number.		0 to 9999	NA	7,8 R	Always active.

Restoring Factory Calibration

- Press the Up  and Down  keys together for six seconds until **FACT** appears in the upper display and **PAGE** appears in the lower display.
- Press the Advance Key  to step through the parameters until the **RES** appears.
- Use the Up Key  to select **YES** in the upper display.
- Press the Infinity Key  to exit the Factory Page.

Calibration information for the Series SD controllers is available in pdf format. Go to www.watlow.com > Literature > Product User Manuals and search on Series SD Calibration Manual.

12

Chapter 12: Features

Saving and Restoring User Settings	62
Saving and Restoring User Profiles	62
Operations Page	62
Tuning the PID Parameters	63
Autotuning	63
Manual Tuning	63
TRU-TUNE+™ Adaptive Control	63
Inputs	64
INFOSENSE™ Temperature Sensing	64
Calibration Offset	64
Filter Time Constant	65
Sensor Selection	65
Access Lockout	65
Set Point Low Limit and High Limit	65
High Scale and Low Scale	66
High Range and Low Range	66
Control Methods	66
Output Configuration	66
Auto (closed loop) and Manual (open loop) Control	66
On-Off Control	67
Proportional Control	67
Proportional plus Integral (PI) Control	68
Proportional plus Integral plus Derivative (PID) Control	68
Dead Band	68
Power Limiting and Power Scaling	68
Non-linear Output Curve	69
Independent Heat and Cool PID	69
Variable Time Base	69
Single Set Point Ramping	70
Alarms	70
Process or Deviation Alarms	70
Alarm Set Points	70
Alarm Hysteresis	71
Alarm Latching	71
Alarm Silencing	71
Retransmit	71
Communications	71
Overview	71
Setting Up a Modbus Network	72
Writing to Non-Volatile Memory	73
Infrared Data Communications (IDC)	73
Troubleshooting	74
Error Messages	76

Saving and Restoring User Settings

Recording setup and operations parameter settings for future reference is very important. If you unintentionally change these, you will need to program the correct settings back into the controller to return the equipment to operational condition.

After you program the controller and verify proper operation, use **[USr.S]** to save the settings into a special section of memory. If the settings in the controller are altered and you want to return the controller to the saved values, use **[USr.r]** to recall the saved settings. The non-profiling version has two sets of user settings and the profiling version only has one set.

To save the Setup and Operations parameters:

1. Ensure all the settings that you want to store are already programmed into the Setup, Programming, and Operations Page parameters.
2. From the Home Page, press the Up **▲** and Down **▼** keys together for six seconds until **[FRct]** appears in the upper display and **[PAGE]** appears in the lower display.
3. Press the Advance Key **⊗** to step through the prompts until the **[USr.S]** prompt appears.
4. Use the Up Key **▲** to select **[YES]***** or **[SEt 1]** or **[SEt 2]**** in the upper display.
5. Press the Infinity Key **∞** to exit the Factory Page.

Note: Only perform the above procedure when you are sure that all the correct settings are programmed into the controller. Saving the settings overwrites any previously saved collection of settings. Be sure to document all the controller settings.

To restore a collection of saved settings:

1. Press the Up **▲** and Down **▼** keys together for six seconds until **[FRct]** appears in the upper display and **[PAGE]** appears in the lower display.
2. Press the Advance Key **⊗** to step through the menu until the **[USr.r]** prompt appears.
3. Use the Up Key **▲** to select **[YES]** in the upper display.
4. Press the Infinity Key **∞** to exit the Factory Page.

Saving and Restoring User Profiles

Profiles can be backed up and saved independently from other user settings. Once all the necessary files and steps have been programmed, the **[PrF.S]** parameter is used to save the profiles into a special section of memory. All ten steps of each of the four profiles is saved even if they are not all being used. If the profile information is altered and the user wants to return to the backup profiles, the **[PrF.r]** parameter will restore the saved profiles.

**** Static set Point version only**

*****Profiling version only**

To save a backup of the profiles:

1. Be sure all profiles are programmed as desired.
2. From the Home Page, press the Up **▲** and Down **▼** keys together for six seconds until **[FRct]** appears in the upper display and **[PAGE]** appears in the lower display.
3. Press the Advance Key **⊗** to step through the menu until the **[PrF.S]** parameter appears.
4. Press the Up Key **▲** to select **[YES]** in the upper display.
5. Press the Infinity Key **∞** to exit the Factory Page.



Caution: Only perform this procedure when you are sure that all the correct profile information is programmed into the controller. This will overwrite all previously saved profiles.

To restore a backup of the profiles:

1. Press the Up **▲** and Down **▼** keys together for six seconds until **[FRct]** appears in the upper display and **[PAGE]** appears in the lower display.
2. Press the Advance Key **⊗** to step through the menu until the **[PrF.r]** parameter appears.
3. Press the Up Key **▲** to select **[YES]** in the upper display.
4. Press the Infinity Key **∞** to exit the Factory Page.

Operations Page

Watlow's patented user-defined menu system improves operational efficiency. The user-defined Operations Page provides you with a shortcut to monitor or change the parameter values that you use most often. You can go directly to the Operations Page from the Home Page by pressing the Advance Key **⊗**.

You can create your own Operations Page with as many as 20 (23 on profiling version) of the active parameters from the list in the Keys and Displays chapter. When a parameter normally located in the Setup Page is placed in the Operations Page, it is accessible through both. If you change a parameter in the Operations Page, it is automatically changed in its original page. If you change a parameter in its original page it is automatically changed in the Operations Page.

The default parameters will automatically appear in the Operations Page.

To change the list of parameters in the Operations Page, hold down the Infinity Key **∞**, then press the Advance Key **⊗**, and hold both down for about six seconds. This will take you to the Programming Page.

Note: On profiling version, keys must be pressed exactly at the same time to enter the Programming Page.

Press the Advance Key **⊗** once to go to the first selection in the page. The parameter choices will appear in the top display and the selection number will appear in the bottom display. Use the Up **▲** or the Down **▼** key to

change the selected parameter in the top display. If you do not want a parameter to appear for that location, select **[nonE]**. To change the other 19 selections, press the Advance Key **[⊕]** to select a place in the page, **[P1]** to **[P20]** (**[P23]** for the profiling version), in the bottom display and use the Up **[↑]** or the Down **[↓]** key to change the parameter selected in the top display.

Changes made to the Operations Page will persist until changed by the operator or defaulted by full defaults or user defaults. User-defined parameters are not overwritten by default parameters if those features become enabled. Only parameters supported by a controller's particular hardware configuration and programming settings will appear.

Tuning the PID Parameters

Autotuning

The autotuning feature allows the controller to measure the system response to determine effective settings for PID control. When autotuning is initiated the controller reverts to on-off control. The temperature must cross the Autotune Set Point four times to complete the autotuning process. Once complete, the controller controls at the normal set point, using the new parameters.

To initiate an autotune, set Autotune **[Aut]** (Operations parameters) to **[On]**. A profile can't be running.

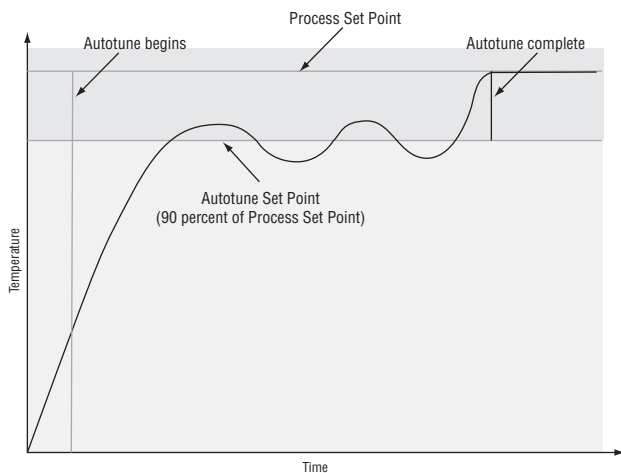

Manual Tuning

In some applications, the autotune process may not come up with PID parameters that provide the process characteristics you desire. If the autotune does not provide satisfactory results, you will have to perform a manual tune on the process:

1. Apply power to the Series SD and establish a set point typically used in your process. If the controller includes the TRU-TUNE+™ option (SD_E-____-____-____-____), set TRU-TUNE+™ Enable to **[no]**.
2. Go to the Operations Page, and establish values for the PID parameters: Proportional Band = 5; Reset* = 0.00; Rate* = 0.00. Autotune should be set to off.

3. When the system stabilizes, watch the process value. If this value fluctuates, increase the proportional band setting until it stabilizes. Adjust the proportional band in 3° to 5° increments, allowing time for the system to stabilize between adjustments.
4. When the process has stabilized, watch the percent power, **[PohT]** or **[PocL]**. It should be stable $\pm 2\%$. At this point, the process temperature should also be stable, but it will have stabilized before reaching set point. The difference between set point and actual can be eliminated with reset.
5. Start with a reset* value of 0.01 (99.99)** and allow 10 minutes for the process temperature to get to set point. If it has not, double (halve) ** the setting and wait another 10 minutes. Continue doubling (halving) ** every 10 minutes until the process value equals the set point. If the process becomes unstable, the reset* value is too large (small) **. Decrease (increase) ** the reset value until the process stabilizes.
6. Increase Rate* to 0.10 minute. Then increase the set point by 11° to 17°C. Monitor the system's approach to the set point. If the process value overshoots the set point, increase Rate* to 0.50 minute. Increase the set point by 11° to 17°C and watch the approach to the new set point. If you increase Rate* too much, the approach to the set point will be very sluggish. Repeat as necessary until the system rises to the new set point without overshoot or sluggishness.

***Note:** With the **[Unit]** parameter set at **[51]** (Setup Page) Integral will appear in place of Reset and Derivative will appear in place of Rate.

****Note:** Integral is the reciprocal of reset. For Integral instead of reset, use the values in parentheses.

For additional information about autotune and PID control, see related features in this chapter.

TRU-TUNE+™ Adaptive Control

If your Series SD controller was ordered with the TRU-TUNE+™ option (SD_E-____-____) the TRU-TUNE+™ feature can be enabled or disabled in the Setup Page. The TRU-TUNE+™ feature is enabled as the default condition. If TRU-TUNE+™ is disabled, the controller will control using fixed PID settings (non adaptive).

The TRU-TUNE+™ adaptive algorithm will optimize the Series SD controller's PID values to improve the controller's ability to control difficult-to-control or dynamic processes. TRU-TUNE+™ monitors the process variable and adjusts the control parameters automatically to keep your process at set point during set point and load changes. When the controller is in the adaptive control mode, it determines the appropriate output signal and, over time, adjusts the control parameters to optimize responsiveness and stability. The TRU-TUNE+™ feature does not function for on-off control.

Autotune Enable **AUT**: The Autotune Enable parameter appears in the Operations Page.

The autotune feature can be enabled if TRU-TUNE+™ is enabled or disabled.

Autotuning with TRU-TUNE+™ adaptive control is a process by which the Series SD controller calculates the PID settings for optimum control. Both heating and cooling PID parameter settings are determined. The autotune feature can also be enabled if TRU-TUNE+™ has been disabled. The autotune generated PID settings are used until the autotune feature is rerun or the PID variable values are manually adjusted by the user or if TRU-TUNE+™ is enabled.

The preferred and quickest method for tuning the Series SD controller when TRU-TUNE+™ is enabled is to use the autotune feature to establish initial control settings and continue with the adaptive mode to fine tune the settings. Enabling the autotune function from the Operations Page starts this two-step tuning function. First the autotune determines initial, rough settings for the PID parameters. Second the loop automatically switches to the adaptive mode, which fine tunes the PID parameters. This function can be used for heat-only, heat-and-cool, and cool-only PID control systems.

Once the process value has been at set point for a suitable period of time (about 30 minutes for a fast process to roughly 2 hours for a slower process) and if no further tuning of the PID parameters is desired or needed, TRU-TUNE+™ can then be disabled. However, only operating the controller in the adaptive mode allows it to automatically adjust to load changes and compensate for differing control characteristics at various set points for processes that are not entirely linear.

Once the PID parameters have been set by the TRU-TUNE+™ adaptive algorithm, the process, if shut down for any reason, can be restarted in the adaptive control mode.

Autotune Aggressiveness **AGG**: This parameter appears in the Setup Page. This parameter is used by the autotune feature to determine how aggressively power is applied to the controllers output to enable the process value to reach the set point.

Undr Under damped. Aggressive PID values are selected during autotune that bring the load quickly to the set point. Overshoot is not critical and is allowed.

OvEr Over damped. PID values are selected during autotune that minimize overshoot. It is not critical that the load reach the set point quickly. Overshoot is critical and is not allowed or kept to a minimum.

Crit Critical damped. PID values are selected during the autotune that bring the load up to the set point at power levels that allow for some overshoot. It is critical to get the load to the set point as fast as possible with minimal overshoot.

Crit Critical damped is the default setting.

Tune Band **band**: This parameter appears in the Setup Page if TRU-TUNE+™ is enabled. Set the controller to automatically adjust the range around set point

over which the controller will continuously tune the control parameters, or enter a fixed value. This parameter is provided for use only in the unlikely event that the controller is unable to automatically tune and stabilize at set point. This may occur with very fast processes. In that case select a large value, such as 300. Otherwise, leave this parameter set to auto.

Values: auto (0) and 1 (1) to 999 (999)

Default: auto (0)

Tune Gain **gain** This parameter appears in the Setup Page if TRU-TUNE+™ is enabled. Choose the target responsiveness of the control algorithm. Settings range from 1, with the least aggressive response and least potential overshoot (lowest gain), to 7, with the most aggressive response and most potential for overshoot (highest gain). The default setting, 4, is recommended for loops with thermocouple feedback and moderate response and overshoot potential.

Values: 1 (1) to 7 (7)

Default: 4 (4)

Inputs

INFOSENSE™ Temperature Sensing

Watlow's INFOSENSE™ feature can improve temperature sensing accuracy by 50%. Watlow's INFO-SENSE™ thermocouples and RTD temperature sensors must be used together to achieve these results.

Each INFOSENSE™ “smart” sensor contains four numerical values that are programmed into the SD memory. These values characterize Watlow sensors, for the controller to provide greater accuracy.

Turn the INFOSENSE™ feature on or off with INFO-SENSE™ Enable **ISEn** (Setup Page). Set the four numerical values supplied with Watlow's INFO-SENSE™ in the **ISP1**, **ISP2**, **ISP3** and **ISP4** parameters.

The four numerical values are found on the tag attached to the INFOSENSE™ sensor. Contact your Watlow salesperson or Watlow authorized distributor for the pricing and availability of Watlow INFOSENSE™ products.

Calibration Offset

Calibration offset allows a device to compensate for an inaccurate sensor, lead resistance or other factors that affect the input value. A positive offset increases the input value, and a negative offset decreases the input value.

The input offset value can be viewed or changed with Calibration Offset **CAL** (Operations parameters).

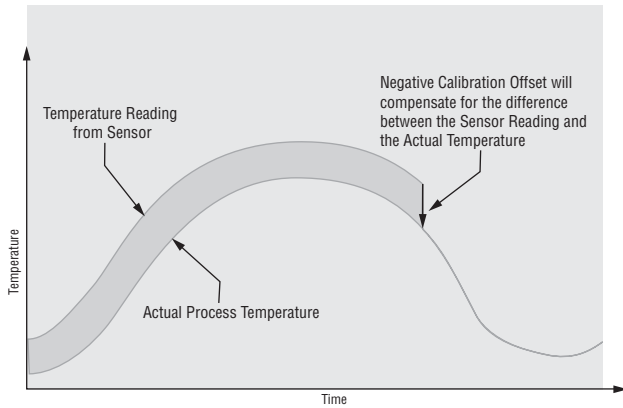

Filter Time Constant

Filtering smoothes an input signal by applying a first-order filter time constant to the signal. The displayed value, the controlled value or both the displayed and controlled values can be filtered. Filtering the displayed value makes it easier to monitor. Filtering the signal may improve the performance of PID control in a noisy or very dynamic system.

Select filter options with Input Filter **[Ftr.E]**. Select the Filter Value with **[FLtr]** (Setup Page).

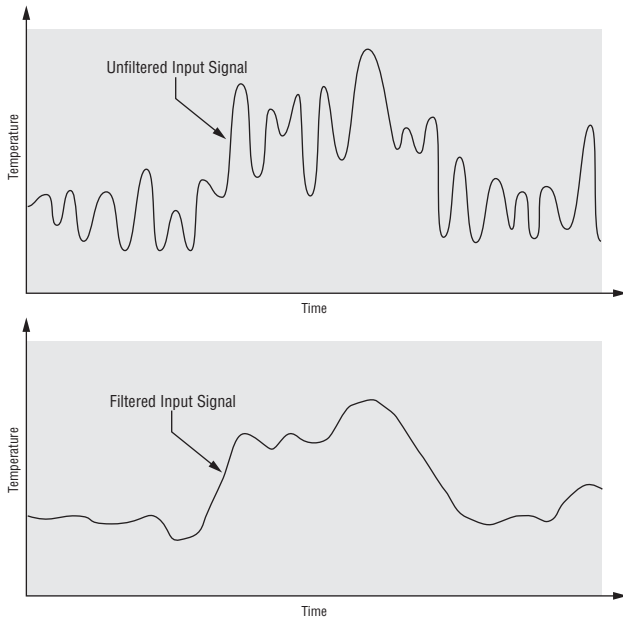

Sensor Selection

You need to configure the controller to match the input device, which is normally a thermocouple, RTD or process transmitter. When you select an input device, the controller automatically sets the input linearization to match the sensor. It also sets high and low limits, which in turn limit the set point range-high and range-low values.

Select the sensor type with Sensor Type **[SEn]** (Setup Page).

Access Lockout

The user's access to the Operations Page can be controlled through the **[LOC]** parameter. The **[LOC]** parameter appears at the end of the Setup Page. It does not affect the Setup, Factory or Programming Pages.

[0] All the Operations Page parameters may be viewed or changed. Full access to profiles on profiling version.

[1] The set point, process value, auto-manual selection and alarm settings are the only visible Operations Page parameters. Set point is adjustable in this level. Auto-manual selection and autotune are permitted. During manual operation, the percent power is adjustable. Full access to profiles on profiling version.

[2] The set point, process value, auto-manual selection and alarm settings are the only visible Operations Page parameters. Set point is adjustable in this level. Auto-manual selection is permitted. During manual operation, percent power is adjustable. Can run profiles, but cannot enter or edit profile information on profiling version.

[3] The set point, process value and alarm settings are the only visible Operations Page parameters. Set point is adjustable. Auto-manual selection is **not** permitted. During manual operation, percent power is adjustable. No access to profile functions on profiling version.

[4] The set point and process values are the only visible Operations Page parameters, set point is not adjustable. During manual operation, percent power is **not** adjustable. No access to profile functions on profiling version.

Set Point Low Limit and High Limit

The controller constrains the set point to a value between a SP low limit and a SP high limit. Note: To stop the Series SD controller from controlling to a set point, press the Down Key while the set point value is equal to the SP.Lo setting. **[OFF]** will be displayed in the lower display and the controller will no longer attempt to maintain a set point.

Set the set point range with Set Point Low Limit **[SP.Lo]** and Set Point High Limit **[SP.hi]** (Setup Page).

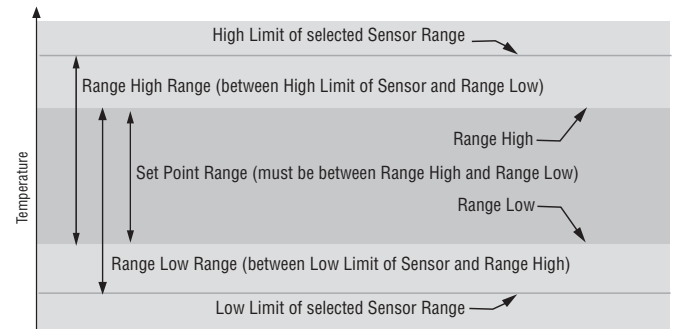

High Scale and Low Scale

When an analog input is selected as process voltage or process current input, you must choose the value of voltage or current to be the low and high ends. For example, when using a 4 to 20 mA input, the scale low value would be 4.00 mA and the scale high value would be 20.00 mA. Commonly used scale ranges are: 0 to 20 mA, 4 to 20 mA, 0 to 5V, 1 to 5V and 0 to 10V.

The Series SD allows you to create a scale range for special applications other than the standard ones listed above. Reversing of the scales from high values to low values is permitted for analog input signals that have a reversed action. For example, 50 psi = 4 mA and 10 psi = 20 mA.

Select the low and high values with Process Scale Low **[ScLo]** and Process Scale High **[ScHi]** (Setup Page).

High Range and Low Range

With a process input, you must choose a value to represent the low and high ends of the current or voltage range. Choosing these values allows the controller's display to be scaled into the actual working units of measurement. For example, the analog input from a humidity transmitter could represent 0 to 100 percent relative humidity as a process signal of 4 to 20 mA. Low scale would be set to 0 to represent 4 mA and high scale set to 100 to represent 20 mA. The indication on the display would then represent percent humidity and range from 0 to 100 percent with an input of 4 to 20 mA.

Select the low and high values with Units Scale Low **[rSLo]** and Units Scale High **[rSHi]** (Setup Page).

Control Methods

Output Configuration

Each controller output can be configured as a heat output, a cool output, an alarm output or deactivated. No dependency limitations have been placed on the available combinations. The outputs can be configured in any combination. For instance, all three could be set to cool.

Analog outputs can be scaled for any desired current range between 0 and 20 mA or voltage range between 0 to 10V. The ranges can be reversed to high-to-low for reverse acting devices.

Heat and cool outputs use the set point and Operations parameters to determine the output value. All heat and cool outputs use the same set point value. Heat and cool each have their own set of control parameters. All heat outputs use the same set of heat control parameters and all cool outputs use the same set of cool output parameters.

Each alarm output has its own set of configuration parameters and set points, allowing independent operation.

Auto (closed loop) and Manual (open loop) Control

The controller has two basic modes of operation, auto mode and manual mode. Auto mode allows the controller to decide whether to perform closed loop control or to follow the settings of the Input Error Failure Mode parameter (Setup Page). The manual mode only allows open loop control. The Series SD controller is normally used in the auto mode. The manual mode is usually only used for specialty applications or for troubleshooting.

Manual mode is open loop control that allows the user to directly set the power level to the controller's output load. No adjustments of the output power level occur based on temperature or set point in this mode.

In auto mode, the controller monitors the input to determine if closed loop control is possible. The controller checks to make certain a functioning sensor is providing a valid input signal. If a valid input signal is present, the controller will perform closed loop control. Closed loop control uses a process sensor to determine the difference between the process value and the set point. Then the controller applies power to a control output load to reduce that difference.

If a valid input signal is not present, the controller will indicate an input error message **[ErrIn]** and then use the Input Error Failure Mode **[FAIL]** setting to determine operation. You can choose to have the controller perform a "bumpless" transfer, switch power to output a preset manual level, or turn the output power off.

Bumpless transfer will allow the controller to transfer to the manual mode using the last power value calculated in the auto mode if the process had stabilized at a ± 5 percent output power level for two minutes prior to sensor failure, and that power level is less than 75 percent.

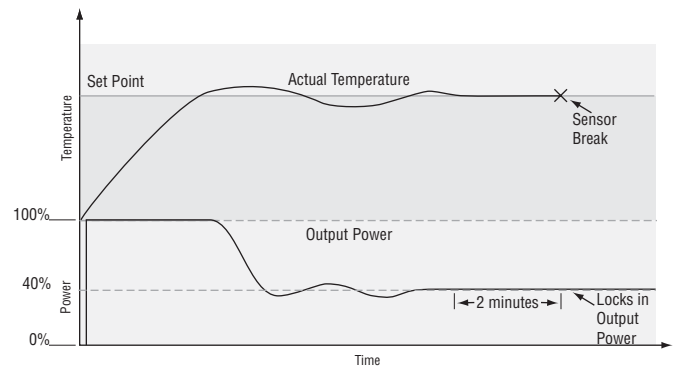

Input Error Latching **[IErr]** (Setup Page) determines the controller's response once a valid input signal returns to the controller. If latching is on **[LAE]**, then the controller will continue to indicate an input error until the error is cleared. To clear a latched alarm, press the Infinity Key ∞ . If latching is off **[nLAE]**, the controller will automatically clear the input error and return to reading the temperature. If the controller was in the auto mode when the input error occurred, it will resume closed loop control. If the controller was in manual mode when the error occurred, the controller will remain in open loop control.

The Auto-Manual Control Indicator Light % is on when the static set point controller is in the manual

mode and it is off while in the auto mode. For the profiling controller, the letter P appears in the left side of the lower display followed by the manual % power set point value. For example, **P 75** indicates the profiling controller is in Manual Mode at 75% power output. You can easily switch between modes if the Auto-Manual Mode **R-P7** parameter is selected to appear in the Operations Page.

To transfer to manual mode from auto mode, press the Advance Key **⊕** until **R-P7** appears in the lower display. The upper display will display **Auto** for auto mode. Use the Up **⬆** or Down **⬇** keys to select **P7777**. The manual set point value will be recalled from the last manual operation.

To transfer to auto mode from manual mode, press the Advance Key **⊕** until **R-P7** appears in the lower display. The upper display will display **P7777** for manual mode. Use the Up **⬆** or Down **⬇** keys to select **Auto**. The automatic set point value will be recalled from the last automatic operation.

Changes take effect after three seconds or immediately upon pressing either the Advance Key **⊕** or the Infinity Key **∞**.

On-Off Control

On-off control switches the output either full on or full off, depending on the input, set point and hysteresis values. The hysteresis value indicates the amount the process value must deviate from the set point to turn on the output. Increasing the value decreases the number of times the output will cycle. Decreasing hysteresis improves controllability. With hysteresis set to 0, the process value would stay closer to the set point, but the output would switch on and off more frequently, and may result in the output “chattering.” On-off control can be selected with Heat Control Method **HEP7** or Cool Control Method **CLP7** (Operations parameters).

NOTE:

Input Error Failure Mode **FRIL does not function in on-off control mode. The output goes off.**

NOTE:

In on-off control set Power Limit 1, 2 and 3 (PL1**, **PL2** and **PL3**) and Output Power Scale High 1, 2 and 3 (**PSH1**, **PSH2** and **PSH3**) to 100%. Set Output Power Scale Low 1, 2 and 3 (**PSL1**, **PSL2** and **PSL3**) to 0%.**

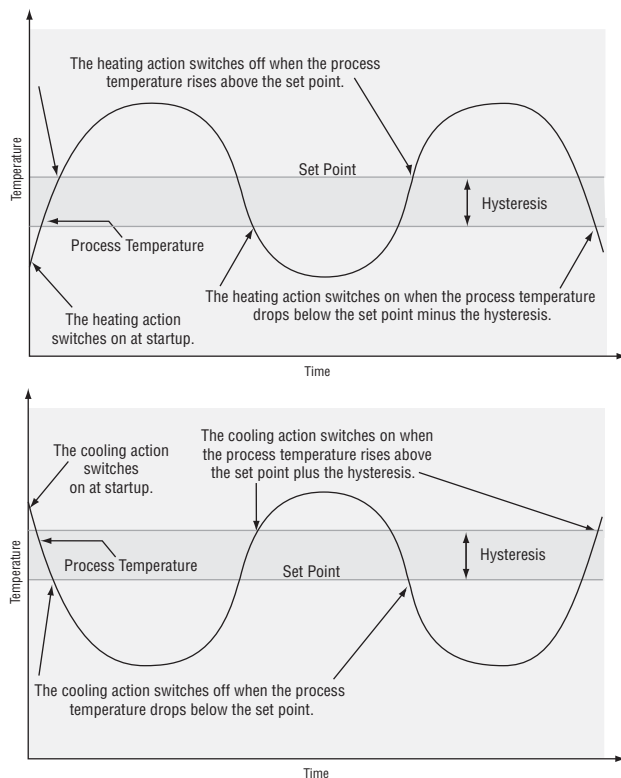

Proportional Control

Some processes need to maintain a temperature or process value closer to the set point than on-off control can provide. Proportional control provides closer control by adjusting the output when the temperature or process value is within a proportional band. When the value is in the band, the controller adjusts the output based on how close the process value is to the set point.

The closer the process value is to the set point, the lower the output power. This is similar to backing off on the gas pedal of a car as you approach a stop sign. It keeps the temperature or process value from swinging as widely as it would with simple on-off control. However, when the system settles down, the temperature or process value tends to “droop” short of the set point.

With proportional control the output power level equals (set point minus process value) divided by the proportional band value.

Adjust the proportional band with Proportional Band Heat **PbHE** or Proportional Band Cool **PbCL** (Operations parameters).

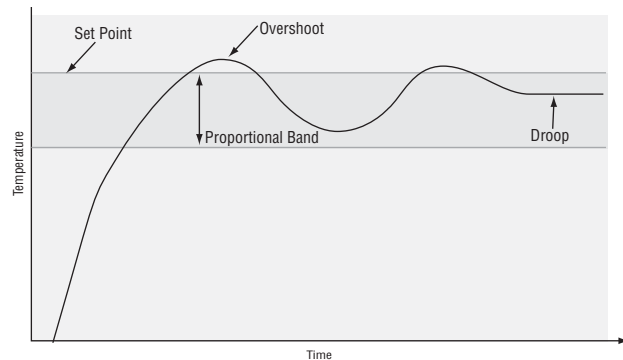

Proportional plus Integral (PI) Control

The droop caused by proportional control can be corrected by adding integral (reset) control. When the system settles down, the integral value is tuned to bring the temperature or process value closer to the set point. Integral determines the speed of the correction, but this may increase the overshoot at startup or when the set point is changed. Too much integral action will make the system unstable. Integral is cleared when the process value is outside of the proportional band.

Integral is in effect if PID Units are set to SI, and is measured in minutes per repeat. A low integral value causes a fast integrating action.

Reset is in effect if PID Units are set to US, and is measured in repeats per minute. A high reset value causes a fast integrating action.

Adjust the integral with Integral Heat **[I_EH_T]** or Integral Cool **[I_EC_L]** (Operations parameters).

Adjust the reset with Reset Heat **[R_EH_T]** or Reset Cool **[R_EC_L]** (Operations parameters).

Proportional plus Integral plus Derivative (PID) Control

Use derivative (rate) control to minimize the overshoot in a PI-controlled system. Derivative (rate) adjusts the output based on the rate of change in the temperature or process value. Too much derivative (rate) will make the system sluggish.

Rate action is active only when the process value is within twice the proportional value from the set point.

Adjust the derivative with Derivative Heat **[D_EH_T]** or Derivative Cool **[D_EC_L]** (Operations parameters).

Adjust the rate with Rate Heat **[R_AH_T]** or Rate Cool **[R_AC_L]** (Operations parameters).

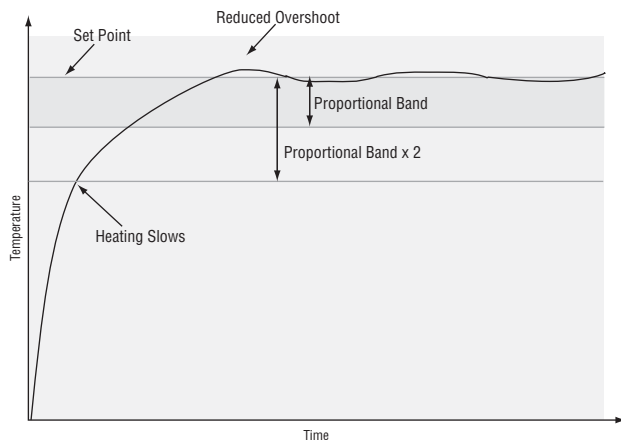

Dead Band

In a PID application the dead bands above and below the set point can save an application's energy and wear by maintaining process temperature within acceptable ranges. Shifting the effective cooling set point and heating set point keeps the two systems from fighting each other.

Proportional action ceases when the process value is within the dead band. Integral action continues to bring

the process temperature to the set point. When the dead band value is zero, the heating element activates when the temperature drops below the set point, and the cooling element switches on when the temperature exceeds the set point.

Adjust the dead bands with Dead Band Heat **[db_HT]** and Dead Band Cool **[db_CL]** (Operations parameters).

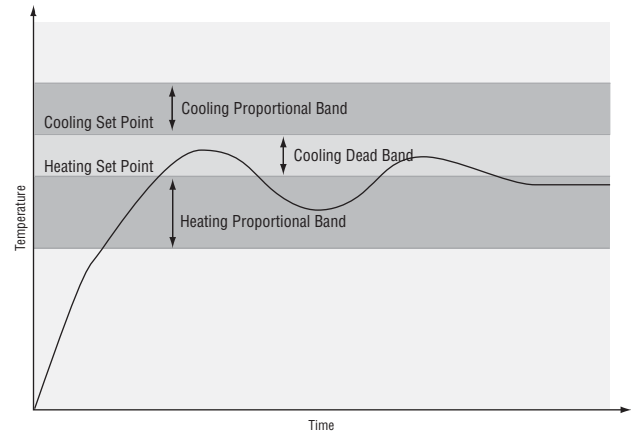

Power Limiting and Power Scaling

Power limiting and power scaling are two methods of placing limitations on a control output. The functions can be used independently or together. An output level calculated from the PID algorithm first has the power limit applied, then the resulting value is processed using power scaling.

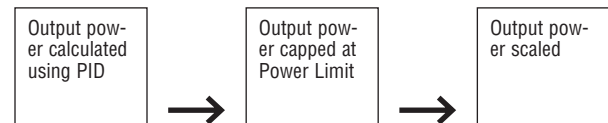

Using both power limiting and power scaling would not usually be necessary. Power limiting provides a basic static cap on power, while power scaling provides a more dynamic range of power limitation.

NOTE:

When output power must be limited, in most cases power scaling will provide better autotune performance than power limiting.

NOTE:

In on-off control set Power Limit 1, 2 and 3 (**[P_L1]**, **[P_L2]** and **[P_L3]**) and Output Power Scale High 1, 2 and 3 (**[P_{SH}1]**, **[P_{SH}2]** and **[P_{SH}3]**) to 100%. Set Output Power Scale Low 1, 2 and 3 (**[P_{SL}1]**, **[P_{SL}2]** and **[P_{SL}3]**) to 0%.

The power limit sets the maximum power for a heat or cool control output. Each control output has its own power limit. For heating outputs it determines the maximum level of heat power and for cool outputs it determines the maximum level of cooling power. A power limit of 100% in effect disables the power limit. If the PID calculations yield a power level that is greater than the power limit setting, then the output power level will be the power limit setting. For example, with a power limit setting of 70%, a PID-calculated power output of

50% would result in an actual output power level of 50%. But if the PID calculated power output is 100%, then the power level will be 70%.

Power scaling establishes the maximum power output and the minimum power output. The output power is then linearly scaled within that range. The default values of Output Power Scale Low of 0% and Output Power Scale High of 100% in effect disable power scaling.

Linear scaling allows the controller to do calculations over the full range of power (0 to 100%) and adjust that calculation within the actual output span. For instance, if scale low is set to 15% and scale high is set to 80%, the output power will always be between 15 and 80%. If the PID calculation is 100%, the output power will be 80%, which is the same result you would get from a power limit of 80%. However, if the PID calculation for heat is 50%, the output will be 50% of the allowable range, which scales to an actual output of 47.5%.

Power limiting and power scaling affect the specified output at all times, including in on-off control, manual mode and autotuning.

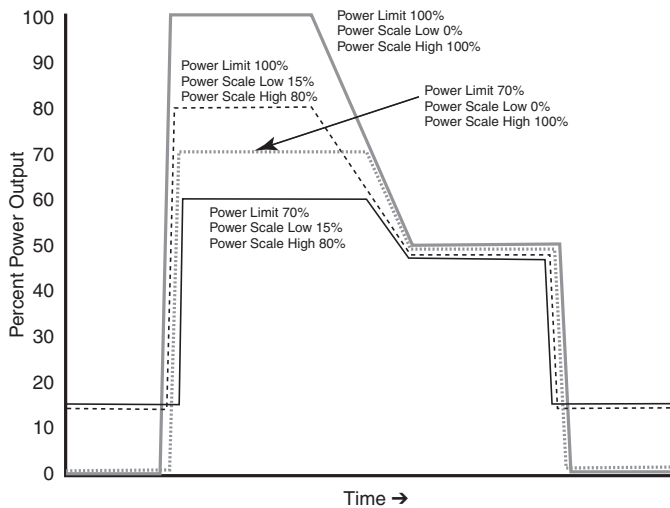

The Power Limit 1, 2 and 3 (**PL 1**, **PL 2** and **PL 3**) and Output Power Scale Low 1, 2 and 3 (**PSL 1**, **PSL 2** and **PSL 3**) and Output Power Scale High 1, 2 and 3 (**PSH 1**, **PSH 2** and **PSH 3**) appear in the Setup Page. The calculated PID heat and cool power values can be viewed with Power Heat (**POHT**) and Power Cool (**POCL**) parameters in the Operations Page.

Non-linear Output Curve

A non-linear output curve may improve performance when the response of the output device is non-linear. If Output Non-linear Function is set to curve 1 (**CRU 1**) or curve 2 (**CRU 2**), a PID calculation yields a lower actual output level than the linear output provides. These output curves are used in plastics extruder applications. Curve 1 is for oil cooled extruders and curve 2 is for water cooled extruders.

Change the linearity for each output with Output Non-linear Function 1, 2 or 3 (**NLF 1**, **NLF 2** or

NLF 3) in the Setup Page.

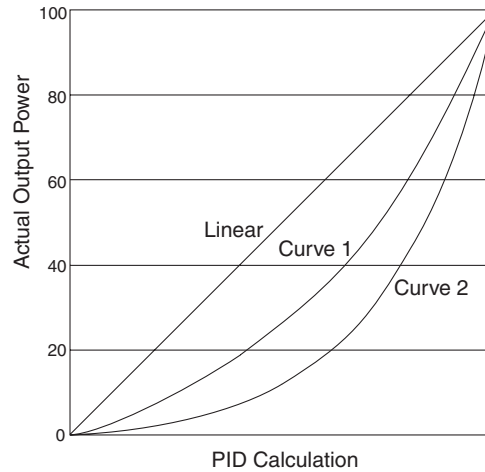

Independent Heat and Cool PID

In an application with one output assigned to heating and another assigned to cooling, each will have a separate set of PID parameters and separate dead bands. The heating parameters take effect when the process temperature is lower than the set point and the cooling parameters take effect when the process temperature is higher than the set point.

Adjust heat and cool PID parameters are Operations parameters.

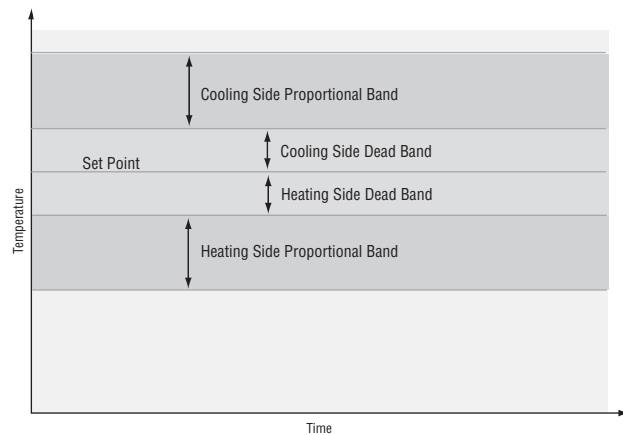

Variable Time Base

Variable time base is the preferred method for controlling a resistive load, providing a very short time base for longer heater life. Unlike phase-angle firing, variable-time-base switching does not limit the current and voltage applied to the heater.

With variable time base outputs, the PID algorithm calculates an output between 0 and 100%, but the output is distributed in groupings of three ac line cycles. For each group of three ac line cycles, the controller decides whether the power should be on or off. There is no fixed cycle time since the decision is made for each group of cycles. When used in conjunction with a zero cross (burst fire) device, such as a solid-state power controller, switch-

ing is done only at the zero cross of the ac line, which helps reduce electrical noise (RFI).

Variable time base should be used with solid-state power controllers, such as a solid-state relay (SSR) or silicon controlled rectifier (SCR) power controller. Do not use a variable time base output for controlling electromechanical relays, mercury displacement relays, inductive loads or heaters with unusual resistance characteristics.

The combination of variable time base output and a solid-state relay can inexpensively approach the effect of analog, phase-angle fired control.

You must select the AC Line Frequency, 50 or 60 Hz.

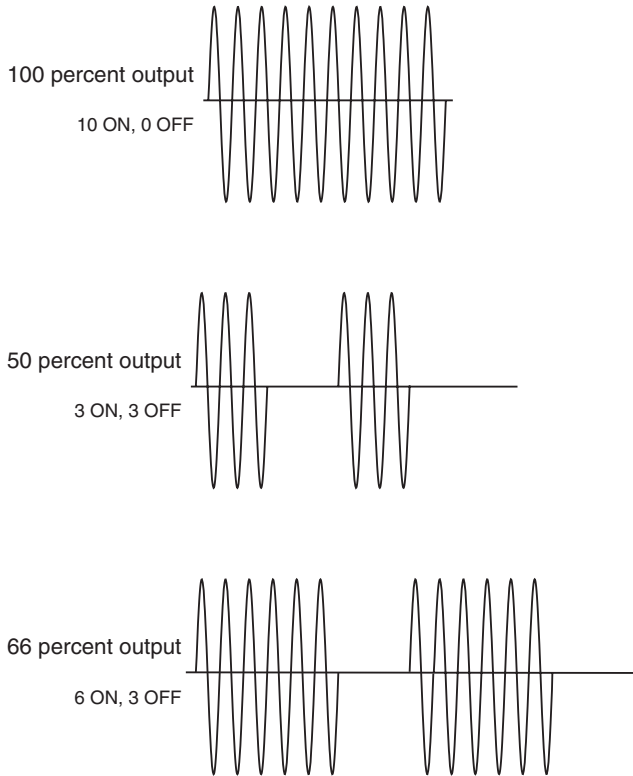

Single Set Point Ramping

(static set point version only SD_C- - - - -)

Ramping protects materials and systems that cannot tolerate rapid temperature changes. The value of the ramp rate is the maximum degrees per minute or hour that the system temperature can change.

Select Ramping Mode **rP** (Setup Page):

OFF ramping not active.

Str ramp at startup.

On ramp at startup or when the set point changes.

Select whether the rate is in degrees per minute or degrees per hour with Ramp Scale **rP.Sc** (Setup Page). Set the ramping rate with Ramp Rate **rP.r.t** (Setup Page).

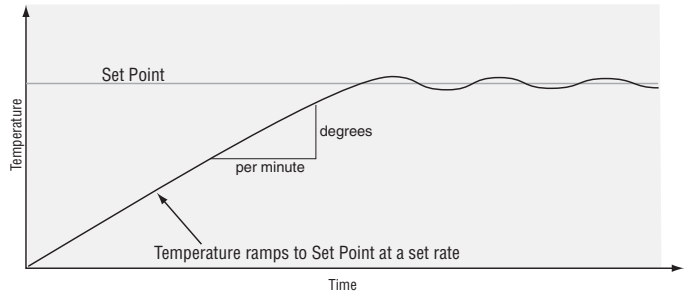
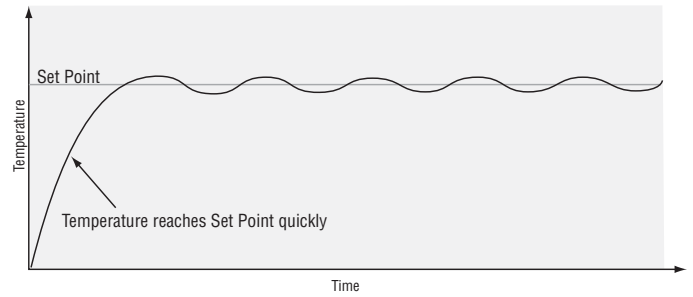

Alarms

Alarms are activated when the process value or temperature leaves a defined range. A user can configure how and when an alarm is triggered, what action it takes and whether it turns off automatically when the alarm condition is over.

Configure alarm outputs in the Setup Page before setting alarm set points.

Process or Deviation Alarms

A process alarm uses one or two absolute set points to define an alarm condition.

A deviation alarm uses one or two set points that are defined relative to the control set point. High and low alarm set points are calculated by adding and/or subtracting offset values from the control set point. If the set point changes, the window defined by the alarm set points automatically changes with it.

Select the alarm type with the Setup Page parameters. View or change process or deviation set points with the Operations parameters.

Alarm Set Points

The alarm high set point defines the process value or temperature that will trigger a high side alarm. It must be higher than the alarm low set point and lower than the high limit of the sensor range.

The alarm low set point defines the temperature that will trigger a low side alarm. It must be lower than the alarm high set point and higher than the low limit of the sensor range.

View or change alarm set points with the Operations parameters.

Alarm Hysteresis

An alarm state is triggered when the process value reaches the alarm high or alarm low set point. Alarm hysteresis defines how far the process must return into the normal operating range before the alarm can be cleared.

Alarm hysteresis is a zone inside each alarm set point. This zone is defined by adding the hysteresis value to the alarm low set point or subtracting the hysteresis value from the alarm high set point.

View or change alarm hysteresis Alarm 1, 2, or 3 Hysteresis, **[HYS1]**, **[HYS2]** or **[HYS3]** (Setup Page).

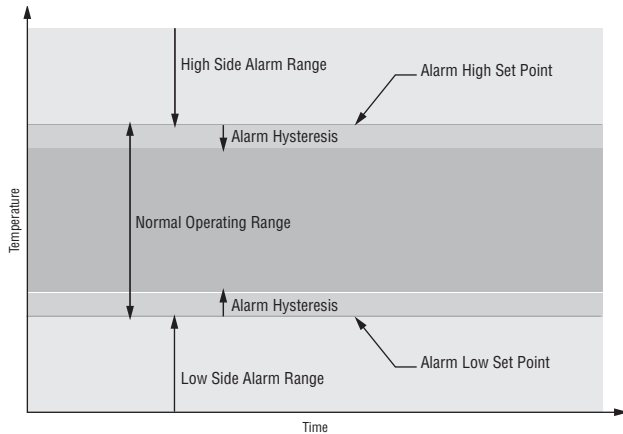

Alarm Latching

A latched alarm will remain active after the alarm condition has passed. To clear a latched alarm, press the Infinity Key ∞ . It can only be deactivated by the user. An alarm that is not latched (self-clearing) will deactivate automatically when the alarm condition has passed.

Turn alarm latching on or off with Alarm 1, 2, or 3 Latching **[LAL1]**, **[LAL2]** or **[LAL3]** (Setup Page).

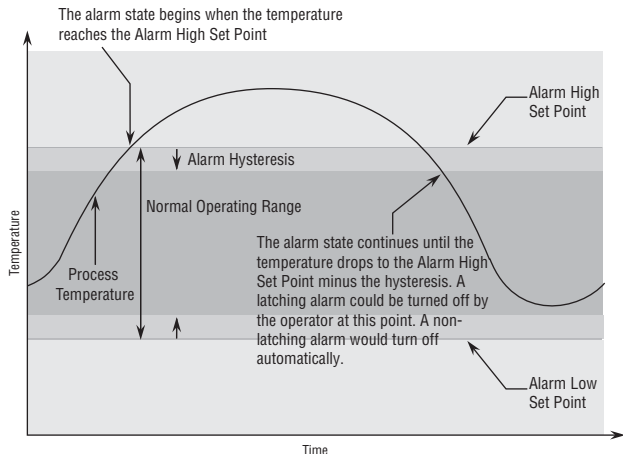

Alarm Silencing

Alarm silencing has two uses:

1. It is often used to allow a system to warm up after it has been started up. With alarm silencing on, an alarm is not triggered when the process temperature is initially lower than the alarm low set point.

The process temperature has to enter the normal operating range beyond the hysteresis zone to activate the alarm function.

2. Alarm silencing also allows the operator to disable the alarm output while the controller is in an alarm state. The process temperature has to enter the normal operating range beyond the hysteresis zone to activate the alarm output function.

If the Series SD has an output that is functioning as a deviation alarm, the alarm is blocked when the set point is changed, until the process value re-enters the normal operating range.

Turn alarm silencing on or off with Alarm 1, 2, or 3 Silencing **[S.L1]**, **[S.L2]** or **[S.L3]** (Setup Page).

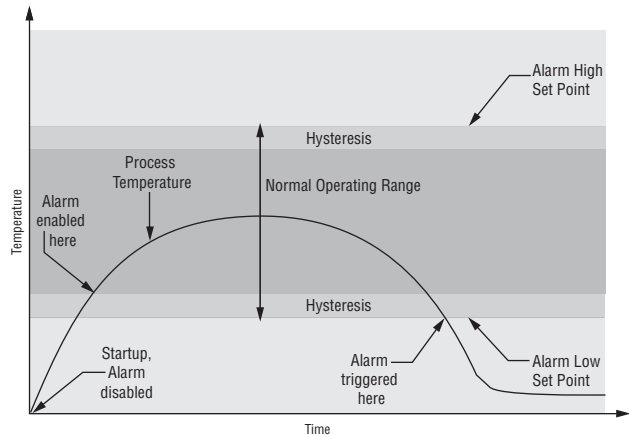

Retransmit

The retransmit feature allows a process output to provide an analog signal that represents the set point or actual process value. The signal may serve as a remote set point for another controller or as an input for a chart recorder to document system performance over time. Any process output can be configured as a retransmit output.

Communications

Overview

A Series SD controller can also be programmed and monitored by connecting it with a personal computer or programmable logic controller (PLC) via serial communications. To do this it must be equipped with an EIA/TIA-485 (SD__ - __U_ - __ - __) communications option for Output 2. Your PC or PLC must have available an EIA/TIA-485 interface or use an EIA/TIA-232 to EIA/TIA-485 converter. See "Selecting an EIA/TIA-232 to EIA/TIA-485 converter" in the Install and Wire chapter. The EIA/TIA-485 option directly supports communication with up to 32 devices on a network or up to 247 devices using a 485 repeater.

Basic communications settings must first be configured on the controller in the Setup Page. Match the Baud Rate **[BAUD]** to that of the computer and select a unique Address **[ADDR]** for each Series SD.

To view or change controller settings with a personal computer, you need to run software that uses the Modbus

RTU protocol to read or write to registers in the controller. See the parameter tables for information about the Modbus registers. These registers contain the parameter values that determine how the controller will function and current input and output values of the system. The address in the tables have been offset by subtracting 40,001 from each one.

Two consecutive registers are addressed for 32-bit data types. The first word, or lower register number, contains the two higher bytes. The second word, or higher register number, contains the two lower bytes of the four byte integer value.

Note: All temperature related values accessed via Modbus are in degrees F.

Setting Up a Modbus Network

1. Wire the controllers.

The Series SD uses an EIA/TIA-485 serial port, which is not typically found in a PC, but can be found on many PLC's. The type of port found in a typical PC is an EIA-232 port. Internal EIA/TIA-485 PC ports are available, but the most common way for a PC to communicate using a EIA-485 port is with an EIA/TIA-232 to EIA/TIA-485 converter. See "Selecting an EIA/TIA-232 to EIA/TIA-485 converter" in the Install and Wire chapter.

The advantages of EIA/TIA-485 are that it is less susceptible to noise and it allows a PC or PLC to communicate with multiple controllers on the same port to form a network. It is important when using EIA/TIA-485, to install the termination resistors along with pull-up and pull-down resistors to ensure reliable communications.

Some newer PCs may only have a USB port. USB-to-serial adapters (usually EIA/TIA 232) are available from a variety of different PC vendors. Some companies offer adapters to convert from USB to EIA/TIA-485 directly.

2. Configure each controller's communications parameters in the Setup Menu using the front panel.

Only a couple of communications parameters need to be configured on the controller, Baud Rate and Modbus Device Address. The choices for Baud Rate are 9600 bps, 19200 bps or 38400 bps. 38400 baud allows for the fastest communication. For compatibility with other devices, reducing noise susceptibility, or increasing communications distance, 9600 bps could be chosen. When using EIA/TIA-485, all devices connected to that port must use the same Baud Rate. The Modbus address is used to identify each controller on the network. With EIA/TIA-485, every controller on the network must have a unique address.

3. Choose a device to communicate with the controller.

The controller can communicate with devices, such as a computer running a software program, a PLC (Programmable Logic Controller) or an OIT (Operator Interface Terminal). Whichever device is chosen, it needs to be able to communicate using the Modbus RTU Protocol. OITs would need to be ordered with Modbus RTU support. PLCs would either have Modbus RTU as a standard feature or it can be made available with an I/O module.

On a computer, the software package to be used would need to have the Modbus RTU capability.

4. Select a software package for the computer.

Select the software package based on what is required from the application. For basic communications (such as reading the process value or setting the set point), Watlow has the Comm7 software package. This is mainly used for diagnostics and basic communications.

The WATVIEW™ software package offers more advanced features. WATVIEW™ is available in three editions, each offering increasing levels of functionality. If you need functionality beyond WATVIEW™ or need to interface with an existing software package, many other third party software packages can interface with the Series SD.

When purchasing a third-party software package, be sure to look for a package that is Modbus RTU compatible or has Modbus RTU drivers. Most third-party packages require you to specify the Modbus registers of the controller to setup the package.

Another option is to custom-create a software package. Using the Modbus register and data information in this user's manual, a software package can be created and tailored to the desired application. To assist in application development, Watlow offers WATCONNECT™, which is a Windows-based software library for Modbus RTU communications. For further information on WATVIEW™ software packages, the WATCONNECT™ software library, or to download the Comm7 software, go to the Watlow web site at <http://www.watlow.com>.

5. Configure the software's communications parameters.

A software package, (be it software for a Computer, a PLC or an OIT) will need to be configured just as the controller was configured, setting the Baud Rate and Address to match. The software package may have additional parameters to set, such as number of data bits, parity and stop bits. For Watlow controllers using modbus, these should always be set at 8 data bits, no parity, and 1 stop bit. This is often written as "8N1". Some software packages may give the option to control the activity of the RTS, CTS and DTR lines, which are sometimes used by EIA-232 to EIA-485 converters. On packages where the Modbus registers for the controller need to be defined, these values can be entered at this time. Be sure to account for offsets.

6. Test the communications.

Once communications is configured, test the link to the controller for verification that everything is wired and configured properly. Check the wiring and configurations if things aren't working. One misplaced wire or one incorrect setting will keep communications from working. When using an EIA-232 to EIA-485 converter, be sure to follow the configuration instructions provided with the converter, as some may require special jumper/switch settings, external power supply requirements or special signals from the software. Some software packages have built-in routines for testing the communications or use Comm7 to help diagnose problems.

7. Start communications with the controller.

With the communications successfully verified, the software is now ready for use with the controller. The above guidelines are the general steps to establishing communications with controllers using Modbus. Some applications may require other steps not mentioned, but would follow the same general process.

8. Programming and configuring the controllers.

When programming and configuring the controllers with a software program, a couple of things must be kept in mind. If the software allows changing Setup parameters such as Input Type, other parameter values that are dependent on that setting may be automatically changed. Some software packages may warn you of this possibility and others may not.

Also, some controllers require that any changes made by the software program to controller parameters that need to be retained in the controller memory must be saved in the non-volatile memory writes register. Any settings not saved to controller memory will be lost when the controller's power is turned off.

Writing to Non-Volatile Memory

The Series SD stores parameter values in non-volatile EEPROM memory. This type of memory has a finite life of approximately 100,000 write cycles. In some applications, you might need to constantly write new values to a particular register. Examples might be the writing of ramping set points or repetitive loops through serial communications. Continuous writes may result in premature controller failure and system downtime.

To prevent premature failure of the EEPROM when frequently writing register values, write a 0 to register 17. Any values written after that, will not be stored to EEPROM. However, this data is lost when power is removed. Register 17 defaults to a value of 1 after each power cycle, writing values to EEPROM again. You must write a 0 to register 17 upon power up to prevent data from being written to EEPROM.

Infrared Data Communications (IDC)

Infrared Data Communications is an option available on the 1/16th, 1/8th and 1/4 Din Series SD products. This option supports wireless communications with PDAs (personal digital assistants) or other devices equipped with infrared communications that support the IrDA 1.0 Standard. IrDA is an acronym for the Infrared Data Association, www.irda.org. A PDA or other master device communicates with the SD Series using Modbus ASCII via IRCOMM over IrDA. IDC supports wireless communications through transparent material to a distance of no less than one meter between devices at a maximum angle of 15 Degrees.

IDC can support complete Series SD parameter configuration and operation. The actual user interface or configuration is dependent on the master device (PDA) application software. A source for this software is Instant HMI from Software Horizons. For more information, go to

www.InstantHMI.com or call (978) 670-8700.

Advantages of this feature include automated logging of key process variables, increased accuracy and ease of use for recipe or configuration setups, and easier controller data exchange in physically restricting environments, such as semiconductor clean rooms. This feature reduces the use of paper to record instrument information as well as human transposition errors.

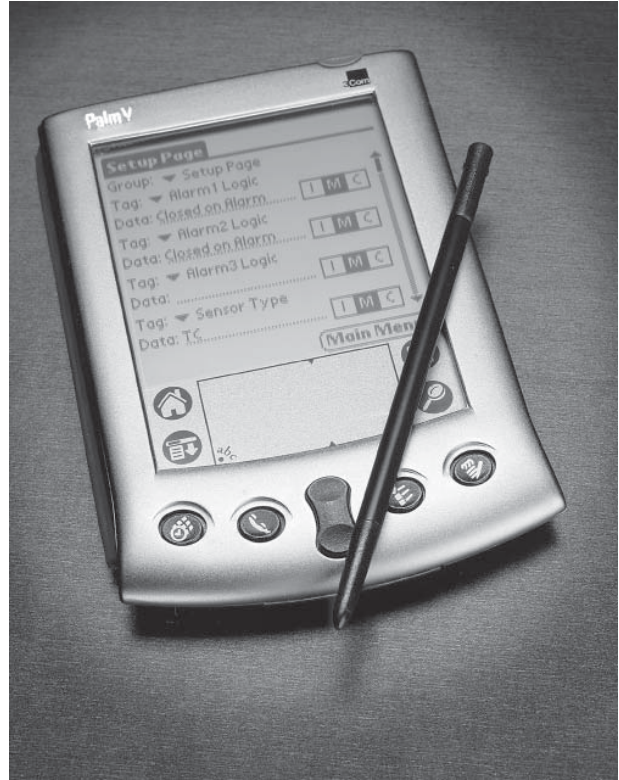

Troubleshooting

Indication	Probable Cause	Corrective Action
<p>No power. Controller appears dead. No display indication in either window.</p>	<p>Power to unit may be off. Fuse may be blown. Breaker may be tripped. Safety interlock door switch, etc. may be activated. Separate system limit control may be latched. Wiring may be open. Input power may be incorrect.</p>	<p>Check switches, fuses, breakers, interlocks, limit devices, connectors, etc. for energized condition and proper connection. Measure power upstream for required level. Verify supply power requirements using the part number. Check wire size. Check for bad connections.</p>
<p>One of the displays is not on.</p>	<p>Active Displays <input type="checkbox"/> d5P (Setup) is not set to <input type="checkbox"/> nor.</p>	<p>Verify that <input type="checkbox"/> d5P is at the desired setting.</p>
<p>Cannot establish serial data communications with the controller.</p>	<p>Address parameter may be incorrectly set. Baud rate parameter may be incorrectly set. Unit-to-unit daisy chain may be disconnected. Communications wiring may be reversed, shorted or open. EIA-485 converter box may be incorrectly wired. Computer's COM port may be incorrectly set up. Communications software setup or address may be incorrect. PC software's protocol or parity may be wrong. Parity should be 8, n, 1. Application software is not working properly. May need termination, pull-up and pull-down resistors.</p>	<p>Check Setup Page and set to correct address. Check Setup Page and set to correct baud rate. Look for a break in the daisy chain. Verify correct connections and test wiring paths. Check converter box wiring and its documentation. Reconfigure computer's COM port setup and verify that communications are ok. Check the communication card documentation for settable variables and operational testing. Restart PC software and check for settings agreement. Verify the COM bus is active. Verify operation with Watlow communications tool available at www.watlow.com. Add termination resistors for EIA/TIA-485 (see Install and Wire chapter).</p>
<p>Cannot establish infrared communications link.</p>	<p>Optical transceiver path obstructed. Infrared device too far away.</p>	<p>Hold the infrared device within range and angle of view to the controller.</p>
	<p>Infrared device software settings do not match controller's infrared settings.</p>	<p>Verify infrared settings.</p>
<p>Output signal is on when it should not be.</p>	<p>Output wiring is incorrect.</p>	<p>Verify the output wiring.</p>
	<p>Output parameters are set incorrectly.</p>	<p>Verify the output parameter settings.</p>
	<p>DC voltage applied to output option "K" (solid-state relay output).</p>	<p>Solid-state relay option can be used with alternating current (ac) voltage only.</p>
<p>Output signal is not on when it should be.</p>	<p>Output wiring is incorrect.</p>	<p>Verify the output wiring.</p>
	<p>For solid-state relay (option "K") and mechanical relay (option "E" or "J"), power must be applied.</p>	<p>Verify that power is applied to the output. The output simply acts as a switch.</p>
	<p>Output parameters are set incorrectly.</p>	<p>Verify the output parameter settings.</p>

Troubleshooting

Indication	Probable Cause	Corrective Action
Getting alarm message A1h , A2h , A3h , A1Lo , A2Lo or A3Lo .	The process value is beyond an alarm set point.	Determine when alarms messages will display and the proper response to an alarm message.
Alarm is occurring when it should not.	Alarm settings are incorrect.	Adjust the alarm settings to be correct for the application.
	Input may be in an error condition.	See error messages.
	Alarm may be latched.	Press the Infinity Key  to unlatch an alarm.
Alarm output indication is incorrect.	Alarm settings are incorrect.	Adjust the alarm settings to be correct for the application.
	Alarm may be silenced.	See the Features chapter for information on alarm silencing.
Alarm is not occurring when it should.	Alarm settings are incorrect.	Adjust the alarm settings to be correct for the application.
Output cycles (turns on and off) too frequently.	Wrong control mode. PID control selected instead of On-Off control.	Select On-Off control mode (HEFF or CLFF Operations Page) and set the desired hysteresis value.
	The cycle time is not set properly.	Adjust the cycle time.
Controller does not control close enough to the set point.	Wrong control mode. On-Off control selected instead of PID.	Select PID control and perform tuning.
	PID is not tuned properly.	Run autotune or perform manual tuning.
Controller's process value reading is decreasing but actual process is increasing.	Thermocouple polarity is reversed.	Check thermocouple connections. All thermocouple connections, including thermocouple extension wire, must maintain the correct polarity for proper operation.
	Analog voltage or analog current input scaling is reversed or incorrect.	Check the settings of the analog output scale low and scale high parameter (Setup Page).
Parameter(s) do not appear.	Parameter is not active.	See Setup and Operation chapters to determine when parameters should appear.
	Parameter lockout is active.	Set the correct level of lockout for access (Setup Page).
	Operations Page is not configured properly.	Select the desired parameters for the Programming Page.
Cannot access Operation Page. Cannot change the set point.	Parameter lockout is active.	Set the correct level of lockout for access (Setup Page).
Profile will not start or resume. Lower display flashes between static set point value and File Number / Step Number. For example, if File 1, Step 1 is not valid, the display will flash 1.1.	Profile step has target set point or Wait-for Process values that are outside of SPLo or SPh values.	Keep target set point or Wait-for Process values inside set point limits or adjust set point limits.
	Jump Loop step is trying to jump to itself.	Correct Jump Loop step (cannot jump to itself).
Profile takes more time to complete than what is programmed. 95d flashes in the lower display.	Guaranteed Soak Deviation is enabled. The program will stop the count down time until the process value returns to within the deviation window. The 95d value may be too small.	If Guaranteed Soak Deviation function isn't required, set 95dE to no to disable it. If Guaranteed Soak Deviation function is required, increase 95d value to reduce the amount of time the process is outside of the deviation window.

Troubleshooting

Error Messages

Indication	Probable Cause	Corrective Action
Er.In Input Error	The sensor may be improperly wired. Sensor wiring may be reversed, shorted or open. The input may be set to the wrong sensor or the controller may not be calibrated. Calibration may have been corrupted.	Check sensor connections. Check sensor connections and sensor wiring. Change Sensor Type SEn (Setup Page) to match the sensor hardware. Restore factory calibration.
Er.Ab Ambient Temperature Error	Ambient temperature may be too hot or too cold. Calibration may be corrupted.	Verify that the temperature surrounding the controller is -18 to 65°C (0 to 149°F). Restore factory calibration.
Er.CS Checksum Error	Settings may have changed unexpectedly.	Press the Infinity Key  to clear the error. Verify settings. If error message persists, contact the factory.

A

Appendix

Specifications

(2396)

Controller

- Microprocessor-based, user-selectable control modes
- Heat and cool autotune for control outputs
- 1 Universal input, 3 outputs (2 outputs on 1/32 DIN)
- Control outputs user-selectable as on-off, P, PI, PID
- Display update: 10 Hz, adjustable digital filter
- Output update: burst, 0.1 to 999.9 seconds
- Communication output isolated
- Displayed in °C, °F or process units
- Static set point model has ramp to set point capability
- Profiling (ramp and soak) model has four profiles, 10 steps per profile. Profiles can be linked together.

Operator Interface

- Dual 4-digit LED displays
- Advance, Up Arrow, Down Arrow, Infinity (Home) tactile keys

Standard Conditions For Specifications

- Ambient temperature 25°C (77°F) ±3°C, rated line voltage, 50 to 60 Hz, 0 to 90% RH non-condensing, 15-minute warm-up

Universal Input

- Sampling rate: 6.5 Hz.

Input Accuracy Span Ranges

Type J:	32 to 1,382°F	or	0 to 750°C
Type K:	-328 to 2,282°F	or	-200 to 1,250°C
Type T:	-328 to 662°F	or	-200 to 350°C
Type E:	-328 to 1,470°F	or	-200 to 799°C
Type N:	32 to 2,282°F	or	0 to 1,250°C
Type C (W5):	32 to 4,200°F	or	0 to 2,316°C
Type D (W3):	32 to 4,200°F	or	0 to 2,316°C
Type PTII (F):	32 to 2,540°F	or	0 to 1,393°C
Type R:	32 to 2,642°F	or	0 to 1,450°C
Type S:	32 to 2,642°F	or	0 to 1,450°C
Type B:	1,598 to 3,092°F	or	870 to 1,700°C
RTD:	-328 to 1,472°F	or	-200 to 800°C
Process:	-1,999 to 9,999 units		

Thermocouple

- Type J, K, T, E, N, C (W5), D (W3), PTII (F), R, S, B thermocouple types. Whole or tenth of a degree resolution.
- >20 MΩ input impedance
- Maximum 20 Ω source resistance

RTD

- 2- or 3-wire platinum, 100 Ω
- DIN curve (.00385 curve)
- Whole or tenth degree indication
- 390 μA nominal RTD excitation current

Process

- Range selectable: 0 to 10V^{dc}, 0 to 5V^{dc}, 1 to 5V^{dc}, 0 to 50 mV^{dc}, 0 to 20 mA, 4 to 20 mA. (Can reverse low and high values.)

- Voltage input impedance 20 kΩ
- Current input impedance 100 Ω
- Minimum current source resistance 1 MΩ
- Input resolution 50,000 bits (approximately) at full scale

Input Accuracy

Thermocouple Input

- Calibration accuracy: ±0.1% of input accuracy span ±1°C at standard conditions
- Temperature stability: ±0.2 degree per degree change in ambient for J, K, T, E, N, F
±0.3% for C and D
±0.4% for B, R (excluding 0 to 100°C) and S (excluding 0 to 100°C)
±0.5% for R and S (entire input accuracy range)

RTD Input

- Calibration accuracy ±0.1% of input accuracy span ±1°C at standard conditions
- Temperature stability: ±0.05 degree per degree change in ambient

Process Input

- Voltage input ranges
Accuracy ±10mV ±1 LSD at standard conditions
Temperature stability ±100 ppm/°C maximum
- Milliamp input ranges
Accuracy ±20μA ±1 LSD at standard conditions
Temperature stability ±100 ppm/°C maximum

Allowable Operating Ranges

Type J:	32 to 1,500°F	or	0 to 816°C
Type K:	-328 to 2,500°F	or	-200 to 1,371°C
Type T:	-328 to 750°F	or	-200 to 399°C
Type E:	-328 to 1,470°F	or	-200 to 799°C
Type N:	32 to 2,372°F	or	0 to 1,300°C
Type C (W5):	32 to 4,200°F	or	0 to 2,316°C
Type D (W3):	32 to 4,200°F	or	0 to 2,316°C
Type PTII (F):	32 to 2,543°F	or	0 to 1,395°C
Type R:	32 to 3,200°F	or	0 to 1,760°C
Type S:	32 to 3,200°F	or	0 to 1,760°C
Type B:	32 to 3,300°F	or	0 to 1,816°C
RTD (DIN)	-328 to 1,472°F	or	-200 to 800°C
Process	-1,999 to 9,999 units		

Output Types

- Output update rate: 6.5 Hz.
- #### Switched DC
- Supply voltage minimum: 6V^{dc} @ 30 mA
 - Supply voltage maximum: 12V^{dc} into an infinite load
- #### Open Collector
- Maximum voltage: 42V^{dc}
 - Maximum current: 250 mA
 - Class 2 power source required
- #### Solid-state Relay
- Optically isolated
 - Zero cross switched

- Without contact suppression
- Minimum load current: 10 mA rms
- Maximum current: 0.5A rms at 24 to 240V~ (ac), resistive
- 20 VA pilot duty, 120/240V~ (ac), inductive
- Must use RC suppression for inductive loads
- Maximum offstate leakage current: 100 µA rms

Electromechanical Relay, Form A

- Minimum load current: 10 mA
- 2 A @ 240V~ (ac) or 30V= (dc) maximum, resistive
- 125 VA pilot duty, 120/240V~ (ac), inductive
- Must use RC suppression for inductive loads
- Electrical life 100,000 cycles at rated current

Electromechanical Relay, Form C

- Minimum load current: 10 mA
- 5 A @ 240V~ (ac) or 30V= (dc) maximum, resistive
- 125 VA pilot duty, 120/240V~ (ac), inductive
- Must use RC suppression for inductive loads
- Electrical life 100,000 cycles at rated current

Process *

- Range selectable: 0 to 20 mA, 4 to 20 mA, 0 to 5V= (dc), 1 to 5V= (dc), 0 to 10V= (dc)
- Reverse or direct acting
- 0 to 10V= (dc) voltage output into 1,000 Ω minimum load resistance
- 0 to 20 mA current output into 800 Ω maximum load resistance
- Resolution:
 - dc ranges: 2.5 mV nominal
 - mA ranges: 5 µA nominal
- Calibration accuracy:
 - dc ranges: ±15 mV
 - mA ranges: ±30 µA
- Temperature stability: 100 ppm/°C

Communications

EIA/TIA-485

- Isolated
- Modbus™ RTU protocol
- 9600, 19200 and 38400 baud rates
- A maximum of 32 units can be connected (with additional 485 repeater hardware, up to 247 units may be connected)
- Sampling rate: 20 Hz

IrDA

- Modbus™ RTU via IRTCOMM over IrDA
- Sampling rate: 20 Hz

Agency Approvals

- UL Listed Process Control UL3121@ (UL 61010C-1), c-UL, IP65 (NEMA 4X). File # E185611.
UL® is a registered trademark of the Underwriter's Laboratories, Inc.
- CE approved. See Declaration of Conformity.
- CSA approved C22.2#24, File 158031
- NSF 2 approved for type E, J, K, T and RTD sensors, File 49660-0002-000.

Terminals

- Touch-safe
- Input power and control outputs: 0.2 to 4 mm² (22 to 12 AWG), 6 mm (0.25 in) strip length
- Sensor inputs and process outputs: 0.1 to 0.5 mm² (28 to 20 AWG), 8 mm (0.30 in) strip length

- Solid or tinned wire recommended for spring clamp style connectors.
- Torque: terminal blocks 1 to 6 (SD _ _ _ [C, K or J] _ _ _ _ _) and 1 to 4 (SD _ _ _ F _ _ _ _ _) are 0.8 Nm (7 in-lb); terminal blocks 12, 13, and 14 are 0.9 Nm (8 in-lb).

Power

- 100 to 240V~ (ac) +10%; -15%; 50/60 Hz, ±5%
- 24V= (ac/dc) +10%; -15%; 50/60 Hz, ±5%; Class 2 power source is required for low-voltage model.
- 10VA maximum power consumption
- Data retention upon power failure via nonvolatile memory

Operating Environment

- -18 to 65°C (0 to 149°F)
- 0 to 90% RH, non-condensing
- Storage temperature: -40 to 85°C (-40 to 185°F)

Dimensions

DIN Size	Behind Panel (max.)	Width	Height	Display Height (in.)
1/32	97.8 mm (3.85 in)	52.6 mm (2.07 in)	29.7 mm (1.17 in)	L — 7.6 mm (0.30) R — 5.6 mm (0.22)
1/16	97.8 mm (2.05 in)	52.1 mm (3.85 in)	52.1 mm (2.05 in)	U — 10.2 mm (0.40) L — 6.1 mm (0.24)
1/8 Vertical	97.8 mm (3.85 in)	52.8 mm (2.08 in)	99.8 mm (3.93 in)	U — 10.2 mm (0.40) L — 6.1 mm (0.24)
1/8 Horizontal	97.8 mm (3.85 in)	99.8 mm (3.93 in)	52.8 mm (2.08 in)	U — 10.2 mm (0.40) L — 6.1 mm (0.24)
1/4	101.1 mm (3.98 in)	99.8 mm (3.93 in)	99.8 mm (3.93 in)	U — 14.2 mm (0.56) L — 10.2 mm (0.40)

Weight (approximate)

- SD3 - 75 g (0.16 lbs)
- SD6 - 100 g (0.22 lbs)
- SD8 - 145 g (0.32 lbs)
- SD4 - 200 g (0.43 lbs)

Functionality Matrix

	Universal Input	Control	Alarm	Process	485 Comm
Input 1					
Output 1					
Output 2					
Output 3					

Note: These specifications are subject to change without prior notice.

Ordering Information and Model Numbers

		S	D	-	-	-	-	-	-	-	A	-	-
DIN Sizes	3, 6, 8, 9 or 4												
3	1/32 DIN												
6	1/16 DIN												
8	1/8 DIN Vertical												
9	1/8 DIN Horizontal												
4	1/4 DIN												
Control Type	C, R* or F												
C	PID Control												
R	Profiling PID Control												
E	PID Control with TRU-TUNE+™												
Power Supply	H or L												
H	100 to 240V~ (ac)												
L	24V≈ (ac/dc)												
Output 1	C, K, F or J												
C	Switched DC												
K	Solid-state Relay Form A, 0.5 Amp												
F	Universal Process												
J	Mechanical Relay Form A, 2 Amp												
Output 2	A, C, K, J or U												
A	None												
C	Switched DC												
K	Solid-state Relay Form A, 0.5 Amp												
J	Mechanical Relay Form A, 2 Amp												
U	EIA/TIA-485 Modbus Communications												
Output 3 (not available on 1/32 DIN)	A, C, K, F or E												
A	None												
C	Switched DC/Open Collector												
K	Solid-state Relay Form A, 0.5 Amp												
F	Universal Process												
E	Mechanical Relay Form C, 5 Amp												
Infrared comms options	A or R												
A	None												
R	Infrared Communications Ready (not available on 1/32 DIN or with TRU-TUNE+™)												
Display Colors and Custom options	RG or RR												
RG	Red Green												
RR	Red Red (Not available on 1/32 DIN)												

*FM-approved limit version is available. For more information, go to www.watlow.com or contact your Watlow representative.

Note: User documentation may be available in other languages. Check www.watlow.com for availability.

Prompt Index

A-P7	36, 40, 67	FILE	47, 56	PI to P23	43, 45, 63	Sid	60
A1h1	25, 38, 41	FLtEr	28, 65	P1HE	27	SIL1	32, 71
A1h1	75	FtEb1	28	P1LE	27	SIL2	32, 71
A1Lo	25, 39, 42	FtEb2	30	PbCL	37, 41, 67	SIL3	33, 71
A1Lo	75	FtEb3	31	Pbht	36, 40, 67	Sn-	60
A2h1	25, 39, 42	FtErE	28, 65	PdEC	26	Sn	60
A2h1	75	95d	34, 53, 56, 75	PL1	29, 67–69	SOAH	49, 53
A2Lo	25, 39, 42	95dE	34, 53, 56	PL2	30, 67–69	SPh1	28, 65
A2Lo	75	hhYS	37, 41	PL3	31, 67–69	SPLo	28, 65
A3h1	25, 39, 42	hoLd	51	PoCL	36, 40, 69	StEP	47, 56
A3h1	75	hour	48, 49, 57	PohE	36, 40, 69	StPt	53
A3Lo	25, 39, 42	hE.P7	36, 40, 67	PrFr	59	StYP	47, 48
A3Lo	75	hYS1	32, 71	PrFS	59	SUEr	60
ACLF	33	hYS2	32, 71	PrOF	47	t.bnd	34, 64
Addr	34, 71	hYS3	33, 71	PrO9	24, 43, 44, 45, 46	t.gn	35, 64
A9rS	34, 64	IErr	33, 66–67	PrOP	38, 41	t9SP	48
AP7A	59	ISEn	26	PSh1	29, 67–69	t.tun	34, 40
AP7b	59	IS.P1	26	PSh2	30, 67–69	Undr	64
AP7n	59	IS.P2	26	PSh3	31, 67–69	Unit	33
AO1U	29	IS.P3	26	PSL1	29, 67–69	USr.r	59
AO3U	31	IS.P4	26	PSL2	30, 67–69	USr.S	59
AuE	36, 40, 64	it	38, 41	PSL3	31, 67–69	UJFP	49
bAud	34, 71	it.CL	37, 68	PStEr	34, 56	UJPr	49, 57
C-F	26	it.hc	40	PEYP	34, 56		
CAL	36, 40, 64	it.hE	37, 68	PLUr	60		
ChYS	38, 41	JC	50	r.LCO	30		
CLP7	37, 41, 67	JF	50	r1h1	29		
Cr it	64–65	JL	50, 53	r1Lo	29		
CtEr1	28	JS	50	r3CO	32		
CtEr2	30	LAE1	32, 71	r3h1	32		
CtEr3	31	LAE2	32, 71	r3Lo	32		
dbCL	38, 68	LAE3	33, 71	r3So	31		
dbhc	41	LF	50	rACL	37, 68		
dbht	37, 68	LF.iL	50	rAht	37, 68		
dE	38, 41	L9c1	32	rAEE	48, 57		
dECL	38, 68	L9c2	32	rECL	37, 68		
dEhc	41	L9c3	33	rEht	36, 68		
dEht	37, 68	Lin	26	rEst	59, 60		
dFLt	59	LOC	21, 35, 65	rESU	51		
dSP	33, 74	P7An	33	r9h1	27, 66		
dSP1	32	P7in	48, 49, 57	r9Lo	27, 66		
dSP2	32	nLF1	29, 69	rP	25, 33		
dSP3	33	nLF2	30, 69	rPrE	34, 70		
dSPL	59	nLF3	31, 69	rPSc	34, 70		
EJC	57	Oh1	29	rPE9	25		
End	50	OhLo	29	SbLd	60		
EnSP	57	O3h1	31	Sch1	27, 66		
Ent1	38, 48, 49, 57	O3Lo	31	ScLo	27, 66		
Ent2	38, 48, 49, 57	OEt1	28	SdEC	26		
Ent3	38, 48, 49, 57	OEt2	30	SEc	48, 49, 57		
ErAb	76	OEt3	30	SELC	51–52, 56		
ErCS	76	OEtY1	60	SEn	26, 65		
Er.in	25, 66–67, 76	OEtY2	60	SEt	23, 26		
FRct	24, 59, 60	OEtY3	60				
FRIL	33, 66–67	OUEr	64				

Index

1/32 DIN displays 20–24

A

access lockout 65
 Active Displays 33, 74
 active output indicator lights 20
 AC Line Frequency 33, 70
 adaptive control 63–64
 Address 71
 adjusting the temperature set point 21
 Advance Key 20
 agency approvals 2, 78
 alarms 70
 deviation 70
 latched 75
 process 70
 silencing 75
 troubleshooting 75
 Alarm 1 High 38, 41
 Alarm 1 Hysteresis 32, 71
 Alarm 1 Latching 32, 71
 Alarm 1 Logic 32
 Alarm 1 Low 39, 42
 Alarm 1 Message 32

- Alarm 1 Silencing 32, 71
- Alarm 2 High 39, 42
- Alarm 2 Hysteresis 32, 71
- Alarm 2 Latching 32, 71
- Alarm 2 Logic 32
- Alarm 2 Low 39, 42
- Alarm 2 Message 32
- Alarm 2 Silencing 32, 71
- Alarm 3 High 39, 42
- Alarm 3 Hysteresis 33, 71
- Alarm 3 Latching 33, 71
- Alarm 3 Logic 33
- Alarm 3 Low 39, 42
- Alarm 3 Message 33
- Alarm 3 Silencing 33, 71
- Alarm High 1 Status 25
- Alarm High 2 Status 25
- Alarm High 3 Status 25
- alarm hysteresis 71
- alarm latching 71
- Alarm Low 1 Status 25
- Alarm Low 2 Status 25
- Alarm Low 3 Status 25
- alarm message 21
- alarm set points 70
- alarm silencing 71
- Ambient Temperature 59
- ambient temperature 76, 77
- Ambient Temperature Error 76
- Analog Output 1 Scale High 29
- Analog Output 1 Scale Low 29
- Analog Output 1 Units 29
- Analog Output 3 Units 31
- Auto-Manual Control Indicator Light 20
- Auto-Manual Mode 36, 40, 67–68
- automatic mode 21
- Autotune 36, 40
- autotune 63, 75
- Autotune Aggressiveness 34, 64
- Autotune Enable 64
- auto (closed loop) 66–67

B

- B&B Converters 18
- back views 10
- Baud Rate 34, 71, 72
- baud rate 3
- biasing and termination 18

C

- calibration 76
 - offset 64–65
 - restoring factory 60

- Series SD Calibration Manual 24
- Calibration Offset 36, 40
- Checksum Error 76
- closed loop control 20, 66
- Closed Loop Set Point 25
- CMC Converter 18
- Comm7 72
- communications 71, 78
- control methods 66–70
- Control Method 1 28
- Control Method 2 30
- Control Method 3 31
- Cool Control Method 37, 41, 67–68
- Cool Hysteresis 38, 41
- Critical damped 64
- Current Ramp Set Point 25

D

- Dead Band 41
- dead band 68
- Dead Band Cool 38, 68
- Dead Band Heat 37, 68
- Default Parameters 59
- Derivative 41
- Derivative Cool 38, 68
- Derivative Heat 37, 68
- Derivative Term 38, 41
- dimensions 78
 - 1/16 DIN 4
 - 1/32 DIN 4
 - 1/4 DIN 5
 - 1/8 DIN 5
- displays 20–24
- display flashes 52, 75
- Display Intensity 59

E

- editing a profile 52
- EEPROM 73
- EIA-232 19
- EIA-232 port 72
- EIA-485 19
- EIA/TIA-232 71
- EIA/TIA-232 to EIA/TIA-485 converters 18
- EIA/TIA-485 11, 19, 71, 74, 78
- EIA/TIA-485 serial port 72
- Elapsed Jump Count 57
- electrical noise (RFI) 70
- electromechanical relay 78
- EM00-GATE-0000. *See* EM Gateway
- EM Gateway 19
- End 50

- End Set Point Value 57
- End Step 50, 53
- error condition 21
- Ethernet Gateway. *See* EM Gateway
- Event Output 1 38, 48, 49
- Event Output 1 status 57
- Event Output 2 38, 48, 49
- Event Output 2 status 57
- Event Output 3 38, 48, 49
- Event Output 3 status 57

F

- Factory Page 24, 59
- Failed File Number 57
- Failed Step Number 57
- File 47
- Filtered Process Value 25
- filter time constant 65
- Filter Value 28, 65
- Fixed Time Base 1 (Cycle Time) 28
- Fixed Time Base 2 (Cycle Time) 30
- Fixed Time Base 3 (Cycle Time) 31
- functionality matrix 78

G

- Greenlee 4–5
- Guaranteed Soak 53
- Guaranteed Soak Deviation 53
- Guaranteed Soak Deviation Enable 34, 56
- Guaranteed Soak Deviation Message 56
- Guaranteed Soak Deviation Value 34, 56

H

- Heat Control 36, 40
- Heat Control Method 67
- Heat Hysteresis 37, 41
- high range 66
- holding and resuming a profile 52
- Home Page 25
- Hours 48, 49
- Hours Remaining 57

I

- IDC. *See* Infrared Data Communications (IDC)
- independent heat and cool PID 69
- Infinity Key 20
- INFOSENSE™ 26
- INFOSENSE™ temperature sensing 2, 64

Infrared Data Communications
(IDC) 73, 78

inputs 64
inputs and outputs 2
input accuracy 77
Input Error 25, 76
Input Error Failure Mode 33,
66–67
Input Error Latching 33, 66
Input Error Power 33
Input Filter 28, 65
installation
1/16 DIN 7
1/32 DIN 6
1/4 DIN 9
1/8 DIN 8

Integral 40
Integral Cool 37, 68
Integral Heat 37, 68
Integral Term 38, 41
IP65/NEMA 4X seal 6–9
IRCOMM. *See* Infrared Data Com-
munications (IDC)
IrDA. *See* Infrared Data Communi-
cations (IDC)
isolation 11, 18

J

jump-loop step 53
Jump Count 50
Jump Count Step Enabled 56
Jump File 50
Jump Loop Step 50
Jump Step 50

K

keys and displays 20–24

L

latched alarm 32, 66–67, 71
Link File 50
Link File Step 50, 53
Lockout 35, 52, 53
lockout 75
lower display 20–24
low range 66
low scale 66

M

manual mode (open loop) 21, 66–67
manual tuning 63
Maximum Recorded Ambient Tem-
perature 59
Minimum Recorded Ambient Tem-
perature 59
Minutes 48, 49
Minutes Remaining 57

Modbus
address 72
monitor profile status 57
profiling registers 56
register numbers 58
Modbus Device Address 34, 72
model numbers 79
monitoring profile status from Mod-
bus 57

N

National Electric (NEC) 11–17
non-linear output curve 69

O

OIT (operator interface terminal)
72
on-off control 67
open collector 77
open loop control 20
Open Loop Output Power 25
operating environment 78
operating ranges 77
Operations Page 22, 62
Operations Parameters 36, 40
operator interface 77
ordering information 79
Output 1 Function 28
Output 1 Retransmit High Scale
29
Output 1 Retransmit Low Scale 29
Output 1 Retransmit Offset 30
Output 1 Retransmit Source 29
Output 1 Type 60
Output 2 Function 30
Output 2 Type 60
Output 3 Function 30
Output 3 High Scale 31
Output 3 Low Scale 31
Output 3 Retransmit High Scale
32
Output 3 Retransmit Low Scale 32
Output 3 Retransmit Offset 32
Output 3 Retransmit Source 31
Output 3 Type 60
output configuration 66
output cycles 75
Output Non-linear Function 1 29,
69
Output Non-linear Function 2 30,
69
Output Non-linear Function 3 31,
69
Output Power Scale High 1 29,
67–69
Output Power Scale High 2 30,
67–69

Output Power Scale High 3 31,
67–69
Output Power Scale Low 1 29,
67–69
Output Power Scale Low 2 30,
67–69
Output Power Scale Low 3 31,
67–69
output types 77
Over damped 64

P

Paktron 13
Parameter Location 1 to 23 43
Parameter Location 1 to 23 for
TRU-TUNE+™ 45
PLC (programmable logic control-
ler) 72
power 78
Power Cool 36, 40, 69
Power Heat 36, 40, 69
power limiting and power scaling
68
Power Limit 1 29, 67–69
Power Limit 2 30, 67–69
Power Limit 3 31, 67–69
Power Type 60
Pre-Run check 52
Pre-Run Menu 51
process
input 77
output 78
value reading 75
Process Decimal Places 26
Process Input High Error 27
Process Input Low Error 27
Process Scale High 27, 66
Process Scale Low 27, 66
Process Value 25
profile
editing 52
errors 52
example 54
holding 52
menus, navigating 51
resuming 52
running 52
step types 52
Profile Run or Hold 51
Profile Select 56
Profile Start 34, 56
Profile State 56
Profile Status Indicator Light 20
Profile Type 34, 56
Profiling Page 47
Programming for TRU-TUNE+™
Page 45
Programming Page 24, 43

- example 44, 46
 - navigating to 62
- Proportional Band Cool 37, 41, 67
- Proportional Band Heat 36, 40, 67
- proportional control 67
- proportional plus integral (PI)
 - control 68
- proportional plus integral plus derivative (PID) control 68
- Proportional Term 38, 41

Q

- Quencharc 13–17

R

- ramping 33, 52, 70
 - to set point 21
- Ramping Mode 33
- Ramp Rate 34, 57, 70
- Ramp Scale 34, 70
- Ramp Target Set Point 25
- Rate 48
- Rate Cool 37, 68
- Rate Heat 37, 68
- removing controller
 - 1/16 DIN 7
 - 1/32 DIN 6
 - 1/4 DIN 9
 - 1/8 DIN 8
- Reset Cool 37, 68
- Reset Heat 36, 68
- Restore Factory Calibration 59
- Restore User Profiles 59
- Restore User Settings 59
- restoring factory calibration 60
- retransmit 71
- RTD input 77
- running a profile 52
- Run Menu 51

S

- Save User Profiles 59
- Save User Settings 59
- screw clamp connectors 6
- Seconds 48, 49
- Seconds Remaining 57
- sensor selection 65
- Sensor Type 26, 65
- Serial Number 1 60
- Serial Number 2 60
- Setup Page 23
- setup steps 3
- Set Point High Limit 28, 65
- set point low and high limit 65
- Set Point Low Limit 28, 65
- Set Point Step 48, 53
- silencing alarms 32–33, 71
- single set point ramping 70

- Soak Step 49, 53
- Software Build Number 60
- Software ID 60
- Software Version 60
- solid-state relay 77
- specifications 77
- Start File Number 56
- Start Step Number 56
- Step 47
- step chart 55
- Step Type 47
- step types
 - set point step 52
 - soak step 53
- switched dc 77

T

- Target Set Point 48
- Temperature Decimal Places 26
- Temperature Units 26
- Temperature Units via Serial Comms 26
- terminals 78
- thermocouple
 - input 77
 - polarity 75
- Thermocouple Linearization 26
- troubleshooting 74
 - alarms 75
 - alarm message 75
 - display flashes 75
 - display problems 74
 - infrared communications 74
 - output cycles 75
 - output signal 74
 - process value reading 75
 - profiles 75
 - serial data communications 74
 - thermocouple polarity 75
- TRU-TUNE+™ Enable 34, 40
- TRU-TUNE+™ adaptive control 63–64
- Tune Band 34, 64
- Tune Gain 35, 64
- tuning the PID parameters 63

U

- Under damped 64
- Units Scale High 27, 66
- Units Scale Low 27, 66
- universal input 77
- upper display 20–24
- Up and Down Keys 20
- user profiles 62
- user settings 62

V

- variable time base 69

W

- Wait-for Process 53
- Wait-for Process Enable 49
- Wait-for Process Value 49, 57
- WATCONNECT™ 72
- Watlow web site 72
- WATVIEW™ 72
- weight 78
- wiring
 - 0 to 10V $\overline{=}$ (dc) process input 12
 - 0 to 20 mA process input 13
 - 0 to 50mV $\overline{=}$ (dc) process input 12
 - high voltage 11
 - low voltage 11
 - Output 1 mechanical relay 13
 - Output 1 process 14
 - Output 1 solid-state relay 13
 - Output 1 switched dc 14
 - Output 2 EIA/TIA-485 15
 - Output 2 mechanical relay 14
 - Output 2 solid-state relay 15
 - Output 2 switched dc 15
 - Output 3 mechanical relay 16
 - Output 3 open collector 17
 - Output 3 process 17
 - Output 3 solid-state relay 16
 - Output 3 switched dc 16
 - RTD input 12
 - thermocouple input 12
- writing to non-volatile memory 73

X

Y

Z

Declaration of Conformity

Series SD

Watlow Winona, Inc.
1241 Bundy Blvd.
Winona, MN 55987 USA

Declares that the following product:

Designation: **Series SD**
Model Numbers: SD(3, 4, 6, 8 or 9)(Any letter or number) – (H or L)(C, F, J or K) (A, C, J, K or U) (A, C, E, F or K) – (A, D, or R) (any three letters or numbers)
Classification: Temperature control, Installation Category II, Pollution degree 2
Rated Voltage: 100 to 240V~ (ac 50/60 Hz) or 24V to 28 ≈ (ac 50/60 Hz or dc)
Rated Power Consumption: 10VA maximum

Meets the essential requirements of the following European Union Directives by using the relevant standards shown below to indicate compliance.

89/336/EEC Electromagnetic Compatibility Directive

EN 61326:	1997	With A1:1998: A2:2002	Electrical equipment for measurement, control and laboratory use – EMC requirements (Industrial Immunity, Class B Emissions).
EN 61000-4-2:	1996	With A1, 1998:	Electrostatic Discharge Immunity
EN 61000-4-3:	1997:		Radiated Field Immunity
EN 61000-4-4:	1995:		Electrical Fast-Transient / Burst Immunity
EN 61000-4-5:	1995	With A1, 1996:	Surge Immunity
EN 61000-4-6:	1996:		Conducted Immunity
EN 61000-4-11:	1994:		Voltage Dips, Short Interruptions and Voltage Variations Immunity
EN 61000-3-2:	2000:	ED.2.	Harmonic Current Emissions
EN 61000-3-3:	1995	With A1:1998:	Voltage Fluctuations and Flicker

73/23/EEC Low-Voltage Directive

EN 61010-1:	1993	With A1: 1995	Safety Requirements of electrical equipment for measurement, control and laboratory use. Part 1: General requirements
--------------------	-------------	----------------------	--

Raymond D. Feller III
Name of Authorized Representative

Winona, Minnesota, USA
Place of Issue

General Manager
Title of Authorized Representative

August 2003
Date of Issue



Signature of Authorized Representative

How to Reach Us

**TOTAL
CUSTOMER
SATISFACTION**
3 Year Warranty

Your Authorized Watlow Distributor:

Corporate Headquarters in the U.S.:

Watlow Electric Manufacturing Co.
12001 Lackland Road
St. Louis, Missouri, USA 63146
Telephone: +1 (314) 878-4600
Fax: +1 (314) 878-6814

Europe:

Watlow GmbH
Industriegebiet Heidig
Lauchwasenstr. 1, Postfach 1165
Kronau 76709 Germany
Telephone: +49 -7253-9400-0
Fax: +49 -7253-9400-44

Watlow France S.A.R.L.
Immeuble Somag, 16 Rue Ampère,
Cergy Pontoise CEDEX 95307 France
Telephone: +33 (1) 3073-2425
Fax: +33 (1) 3073-2875

Watlow Italy S.r.l.
Via Meucci 14,
20094 Corsico MI
Italy
Telephone: +39 (02) 4588841
Fax: +39 (02) 458-69954

Watlow Limited
Robey Close, Linby Industrial Estate,
Linby Nottingham England, NG15 8AA
Telephone: +44 (0) 115 9640777
Fax: +44 (0) 115 9640071

Latin America:

Watlow de México
Av. Epigmenio Gonzalez #5,
Col. Parques Industriales,
Querétaro, Qro. México CP-76130
Telephone: +52 442 217-6235
Fax: +52 442 217-6403

Asia/Pacific:

Watlow Australia Pty., Ltd.
23 Gladstone Park Drive,
Tullamarine, Victoria 3043 Australia
Telephone: +61 (39) 335-6449
Fax: +61 (39) 330-3566

Watlow China, Inc.
Room 1903, Chang De Building
No. 478-5 Chang Shou Road
Shanghai 200060 China
Telephone: +86 (21) 62772138
+86 (21) 62273133
Fax: +86 (21) 62278559

Watlow Japan Ltd. K.K.
Azabu Embassy Heights 106,
1-11-12 Akasaka,
Minato-ku, Tokyo 107-0052 Japan
Telephone: +81-3-5403-4688
Fax: +81-3-5575-3373

Watlow Korea Co., Ltd.
20-6 Yangjae-dong, Seocho-gu
Seoul, Korea 137-130
Telephone: +82 (2) 575-9804
Fax: +82 (2) 575-9831

Watlow Malaysia Sdn Bhd
38B Jalan Tun Dr Awang
11900 Bayan Lepas
Penang Malaysia
Telephone: +60 (4) 641-5977
Fax: +60 (4) 641-5979

Watlow Singapore Pte. Ltd.
55 Ayer Rajah Crescent, #03-23
Singapore 139949
Telephone: +65 67739488
Fax: +65 67780323

Watlow Electric Taiwan
10F-1 No. 189
Chi-Shen 2nd Road,
Kaohsiung, Taiwan, 801
Telephone: +886 (7) 288-5168
Fax: +886 (7) 288-5568