

Technical Information

iTEMP TMT36

Temperature transmitter



Form B (flat face) head transmitter with IO-Link interface

Application

- The temperature transmitter is characterized by its reliability, long-term stability, high precision and diagnostic functions
- For maximum safety and availability
- Installation in terminal head form B (flat face), or on DIN rail with DIN rail clip
- IO-Link
1x PNP, NPN or push-pull switch output, configurable

Your benefits

- Diagnostics information according to NAMUR NE107
- Fast and tool-free wiring thanks to push-in terminal technology, optional
- High accuracy and flexibility with Callendar-van Dusen equation
- Easy and cost-effective solution through digital communication via IO-Link

Table of contents

Function and system design	3	Certificates and approvals	10
Measuring principle	3	MTTF	10
Measuring system	3	Ordering information	10
Input	3	Accessories	10
Measured variable	3	Device-specific accessories	10
Measuring range	4	Communication-specific accessories	10
Output	4	Service-specific accessories	11
Output signal	4	Supplementary documentation	11
Switch output	4		
Failure information	4		
Damping	4		
Protocol-specific data	4		
Switch-on delay	4		
Power supply	5		
Supply voltage	5		
Current consumption	5		
Electrical connection	5		
Terminals	5		
Performance characteristics	5		
Response time	5		
Reference conditions	5		
Maximum measurement error	5		
Sensor adjustment	6		
Operating influences	6		
Mounting	7		
Mounting location	7		
Ambient conditions	7		
Ambient temperature	7		
Storage temperature	7		
Altitude	7		
Humidity	7		
Climate class	7		
Degree of protection	7		
Shock and vibration resistance	7		
Electromagnetic compatibility (EMC)	7		
Overvoltage category	8		
Pollution degree	8		
Mechanical construction	8		
Design, dimensions	8		
Weight	8		
Materials	8		
Human interface	9		
Operation concept	9		
Onsite operation	9		
Onsite display	9		
System integration	9		

Function and system design

Measuring principle

Electronic recording and conversion of RTD input signals in industrial temperature measurement. An RTD (Resistance Temperature Detector) is a sensor whose resistance changes when its temperature changes. The resistance increases with increasing temperature of the sensor.

Measuring system

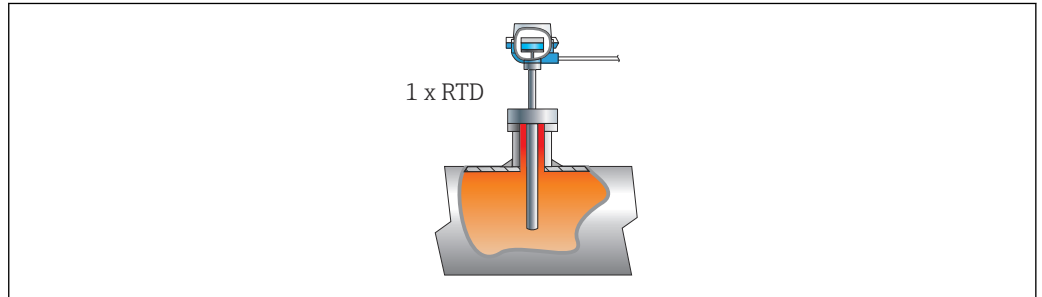

1 Installed head transmitter - 1 x RTD wired directly

Endress+Hauser offers a comprehensive range of industrial thermometers with resistance sensors. When combined with the temperature transmitter, these components form a complete measuring point for a wide range of applications in the industrial sector.

The temperature transmitter is an IO-Link device with a measurement input and an IO-Link interface. The device is mounted in a terminal head form B (flat face) as per DIN EN 50446.

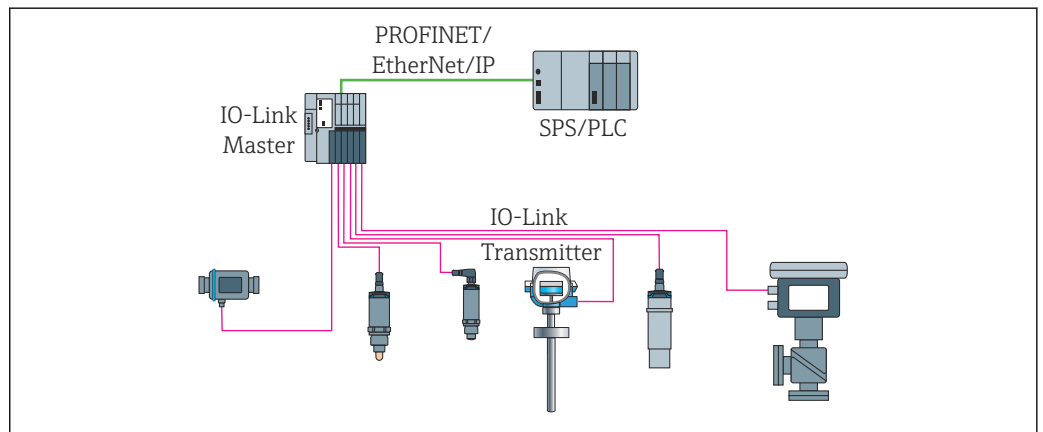

2 Temperature transmitter with IO-Link interface

Standard diagnostic functions

- Cable open-circuit, short-circuit of sensor wires
- Internal device errors
- Overrange and underrange detection
- Device temperature overrange/underrange detection
- Low voltage detection
- Simulation
- Overload at the switch output

Input

Measured variable

Temperature

Resistance thermometer (RTD) as per standard	Description	α	Measuring range limits
IEC 60751:2022	Pt100 (1) Pt1000 (4)	0.003851	-200 to +850 °C (-328 to +1562 °F) -200 to +500 °C (-328 to +932 °F)
-	Callendar-Van Dusen	-	The measuring range limits are specified by entering the limit values that depend on the coefficients A to C and R ₀ .
<ul style="list-style-type: none"> ▪ Type of connection: 2-wire, 3-wire or 4-wire connection, sensor current: ≤ 0.3 mA ▪ Cable resistance compensation possible in 2-wire version (0 to 30 Ω) ▪ With 3-wire and 4-wire connection, sensor wire resistance up to max. 50 Ω per wire 			

Output

Output signal C/Q (IO-Link or switch output)

Switch output

- 1 × PNP, NPN or push-pull switch output, configurable
- Switching capacity $I_a \leq 150$ mA
- Voltage drop PNP, NPN ≤ 2 V
- Overload protection: The switching current load is automatically tested. The device switches to a safe state if an overload is detected. The diagnostic message **Overload at the switch output** is issued.
- Switch functions:
 - Hysteresis or window function
 - NC contact or NO contact

Failure information Failure information is generated if the measuring information is missing or not valid. The device displays the three diagnostic messages with the highest priority.

The fault state of the switch output can be configured: On, off, high-impedance.

Damping	Configurable sensor input damping	0 to 120 s
	Factory setting	0 s

Protocol-specific data	IO-Link specification	Version 1.1.3
	Device ID	0x93FE01
	Manufacturer ID	0x0011 (17)
	IO-Link Smart Sensor Profile 4.3.1	Supported: <ul style="list-style-type: none"> ▪ Identification and diagnosis ▪ Measuring and switching sensor, floating point, 1 channel
	SIO	Yes
	IO-Link transmission rate	COM2; 38.4 kBaud
	Minimum cycle time	10 ms
	Process data width	6 bytes
	IO-Link data storage	Yes
	Block configuration	Yes

Switch-on delay ≤ 5 s, until the first valid measured value signal is present

Power supply

Supply voltage $U = 18 \text{ to } 30 \text{ V}_{DC}$, protected against reverse polarity

Current consumption $I \leq 11 \text{ mA}$

Electrical connection

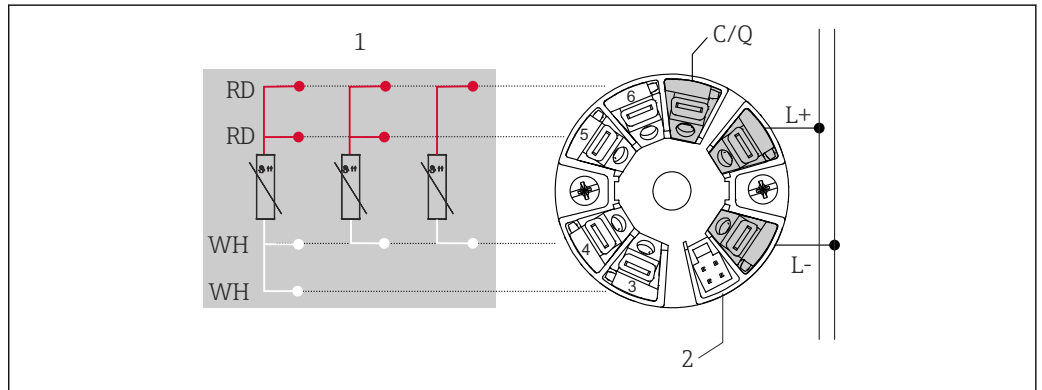

3 Terminal assignment of head transmitter

- 1 RTD sensor input: 4-, 3- and 2-wire
- 2 Display connection
- L+ Power supply 18 to 30 V_{DC}
- L- Power supply 0 V_{DC}
- C/Q IO-Link or switch output

Terminals

Choice of screw-type or push-in terminals:

Terminal design	Cable design	Cable cross-section
Screw terminals	Rigid or flexible	$\leq 1.5 \text{ mm}^2$ (16 AWG)
Push-in terminals ¹⁾ (Cable design, stripping length = min. 10 mm (0.39 in))	Rigid or flexible	0.2 to 1.5 mm ² (24 to 16 AWG)
	Flexible with ferrules (with or without plastic ferrule)	0.25 to 1.5 mm ² (24 to 16 AWG)

1) Ferrules must be used with push-in terminals and when using flexible cables with a cable cross-section of $\leq 0.3 \text{ mm}^2$.

Performance characteristics

Response time

Response time:

Resistance thermometer (RTD)	$\leq 0.5 \text{ s}$
------------------------------	----------------------

Reference conditions

- Calibration temperature: $+25 \text{ °C} \pm 3 \text{ K}$ ($77 \text{ °F} \pm 5.4 \text{ °F}$)
- Supply voltage: 24 V DC
- 4-wire circuit for resistance adjustment

Maximum measurement error

In accordance with DIN EN 60770 and the reference conditions specified above. The measurement error data correspond to $\pm 2 \sigma$ (Gaussian distribution). The data include non-linearities and repeatability.

	Measurement error (\pm)
in the entire measuring range	0.15 K

Sensor adjustment**Sensor-transmitter matching**

The device enables the following method to improve the temperature measurement accuracy of RTD sensors significantly:

Callendar-Van Dusen equation:
 $R_T = R_0[1 + AT + BT^2 + C(T - 100)T^3]$

The coefficients A, B and C are used to match the sensor and transmitter in order to improve the accuracy of the measuring system. The coefficients for a standard sensor are specified in IEC 60751. If no standard sensor is available or if greater accuracy is required, the coefficients for each sensor can be determined specifically with the aid of sensor calibration.

Sensor-transmitter matching using the method mentioned above significantly improves the temperature measurement accuracy of the entire system. This is because the transmitter uses the specific data pertaining to the connected sensor to calculate the measured temperature, instead of using the standardized sensor curve data.

1-point adjustment (offset)

Shifts the sensor value

Operating influences

Influence of ambient temperature and supply voltage on operation for resistance thermometers (RTD) in the entire measuring range

Description	Standard	Ambient temperature: Influence (±) per 1 °C (1.8 °F) change	Supply voltage: Influence (±) per V change
Pt100 (1)	IEC 60751:2008	0.04 °C (0.07 °F)	0.02 °C (0.04 °F)
Pt1000 (4)		0.02 °C (0.03 °F)	0.01 °C (0.02 °F)

Long-term drift (±)		
after 1 year	after 3 years	after 5 years
Based on measured value		
0.05 K	0.06 K	0.07 K

Calculation of the maximum measurement error:
 $\sqrt{(\text{Measurement error}^2 + \text{Influence of ambient temperature}^2 + \text{Influence of supply voltage}^2)}$

Mounting

Mounting location

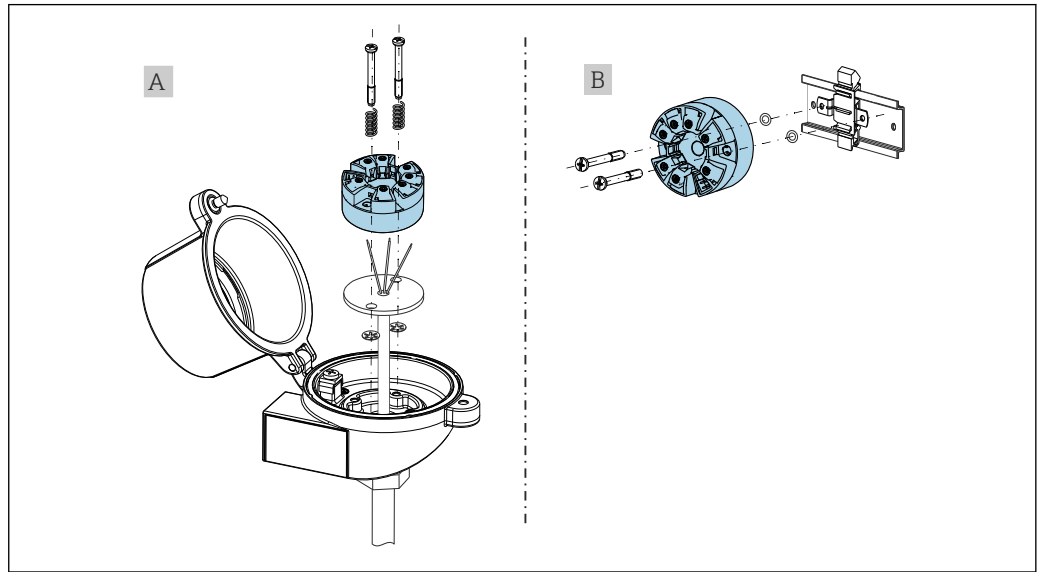

- A Terminal head form B (flat face) as per DIN EN 50446, direct installation on insert with cable entry (middle hole 7 mm (0.28 in))
- B With clip on DIN rail as per IEC 60715 (TH35)



When installing the head transmitter in a terminal head form B (flat face), make sure there is sufficient space in the terminal head!

Ambient conditions

Ambient temperature	-40 to +85 °C (-40 to +185 °F)
Storage temperature	-50 to +100 °C (-58 to +212 °F)
Altitude	Up to 4 000 m (13 123 ft) above sea level.
Humidity	<ul style="list-style-type: none"> ■ Condensation: Permitted ■ Maximum relative humidity: 95 % as per IEC 60068-2-30
Climate class	Climate class C1 as per IEC 60654-1
Degree of protection	Head transmitter with screw-type or push-in terminals: IP 20. In the installed state, it depends on the terminal head used.
Shock and vibration resistance	<p>Vibration resistance according to IEC 60068-2-6:</p> <ul style="list-style-type: none"> ■ 5 to 25 Hz, 1.6 mm ■ 25 to 100 Hz, 4 g <p>Vibration resistance according to IEC 60068-2-27:</p> <ul style="list-style-type: none"> ■ 30 g, 18 ms ■ KTA 3505 (Section 5.8.4)
Electromagnetic compatibility (EMC)	<p>CE conformity</p> <p>Electromagnetic compatibility in accordance with all the relevant requirements of the IEC/EN 61326 series and NAMUR Recommendation EMC (NE21). For details, refer to the Declaration of Conformity.</p>

Maximum measurement error <1% of measuring range.

Interference immunity as per IEC/EN 61326 series, industrial requirements

Interference emission as per IEC/EN 61326 series (CISPR 11), Class B equipment, Group 1

IO-Link

The requirements of IEC/EN 61131-9 are met in IO-Link mode.

Overvoltage category Overvoltage category II

Pollution degree Pollution degree 2

Mechanical construction

Design, dimensions Dimensions in mm (in)

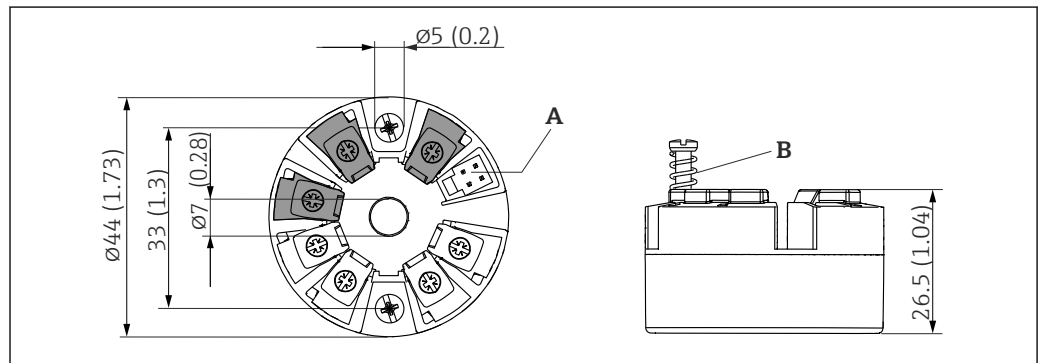

A0052516

4 Version with screw terminals

A Display connection

B Spring travel $L \geq 5 \text{ mm}$ (0.2 in) (not for US - M4 securing screws)

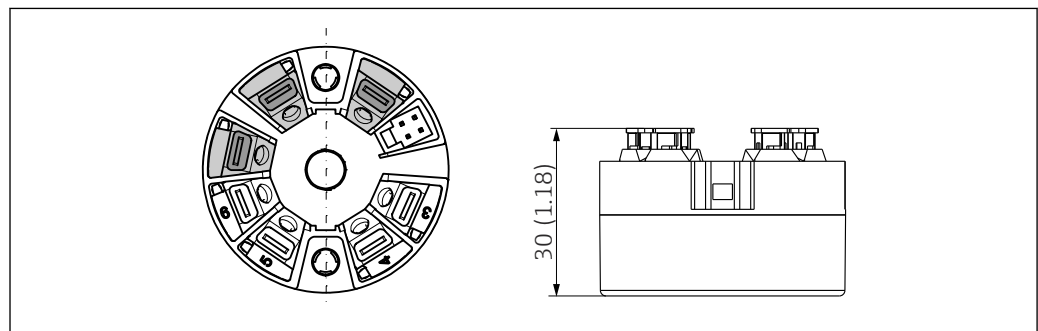

A0052523

5 Version with push-in terminals. Dimensions are identical to the version with screw terminals, apart from housing height.

Weight 40 to 50 g (1.4 to 1.8 oz)

Materials

All the materials used are RoHS-compliant.

- Housing: polycarbonate (PC)
- Terminals:
 - Screw terminals: nickel-plated brass
 - Push-in terminals: tin-plated brass, contact springs 1.4310, 301 (AISI)
- Potting compound: SIL gel

Human interface

Operation concept	The device-specific parameters are configured via IO-Link. There are specific configuration or operating programs from different manufacturers available to the user for this purpose. The device description file (IODD) is provided for the transmitter.
Onsite operation	There are no operating elements directly on the device. The temperature transmitter is configured via remote operation.
Onsite display	There are no display elements on the device. There is the option of using the attachable measured value display TID10 together with the head transmitter. The display provides plain-text information on the current measured value and the measuring point identification. In the event of a fault in the measurement chain, this will be displayed in inverse color showing the channel ident and error number. DIP switches can be found on the rear of the display. These enable hardware settings to be made e.g. write protection.

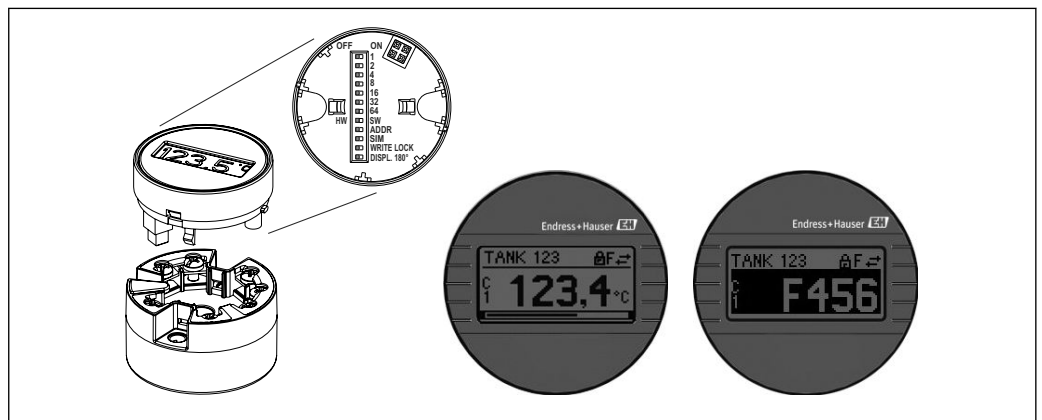

A0020347

6 Attachable measured value display TID10 with bar graph indicator (optional)

i If the head transmitter is installed in a field housing and used with a display, an enclosure with a glass window in the cover must be used.

System integration

IO-Link

In order to integrate field devices into a digital communication system, the IO-Link system needs a description of the device parameters, such as output data, input data, data format, data volume and supported transmission rate. This data is available in the IODD (IO Device Description) which is provided to the IO-Link master via generic modules when the communication system is commissioned.

Download via endress.com

1. endress.com/download
2. Select **Device Driver** from the search options shown.
3. For **Type** select "IO Device Description (IODD)".
4. Select the **Product Code** or enter it as text.
 - ↳ A list of search results is displayed.
5. Download the appropriate version.

Download via ioddfinder

1. ioddfinder.io-link.com
2. For **Manufacturer** select "Endress+Hauser".
3. Enter the **Product Name**.
 - ↳ A list of search results is displayed.
4. Download the appropriate version.

Certificates and approvals

Current certificates and approvals for the product are available at www.endress.com on the relevant product page:

1. Select the product using the filters and search field.
2. Open the product page.
3. Select **Downloads**.

MTTF

371 years

The mean time to failure (MTTF) denotes the theoretically expected time until the device fails during normal operation. The term MTTF is used for systems that cannot be repaired, e.g. temperature transmitters.

Ordering information

Detailed ordering information is available from your nearest sales organization www.addresses.endress.com or in the Product Configurator at www.endress.com:

1. Select the product using the filters and search field.
2. Open the product page.
3. Select **Configuration**.



Product Configurator - the tool for individual product configuration

- Up-to-the-minute configuration data
 - Depending on the device: Direct input of measuring point-specific information such as measuring range or operating language
 - Automatic verification of exclusion criteria
 - Automatic creation of the order code and its breakdown in PDF or Excel output format
 - Ability to order directly in the Endress+Hauser Online Shop

Accessories

Various accessories, which can be ordered with the device or subsequently from Endress+Hauser, are available for the device. Detailed information on the order code in question is available from your local Endress+Hauser sales center or on the product page of the Endress+Hauser website:

www.endress.com.



Device-specific accessories

Adapter for DIN rail mounting, clip as per IEC 60715 (TH35) without securing screws
Standard - DIN mounting set (2 screws + springs, 4 securing disks and 1 display connector cover)
US - M4 securing screws (2 M4 screws and 1 CDI connector cover)

Communication-specific accessories

Accessories	Description
FieldPort SFP20	Mobile configuration tool for all IO-Link devices: <ul style="list-style-type: none"> ▪ The FieldPort SFP20 is a USB interface for the configuration of IO-Link devices. The FieldPort SFP20 can be connected to a laptop or tablet via a USB cable. ▪ A point-to-point connection between the laptop and IO-Link devices is possible with the FieldPort SFP20. ▪ M12 connection for IO-Link field devices
IO-Link master BL20	IO-Link master from Turck for DIN rails supports PROFINET, EtherNet/IP and Modbus TCP. With web server for easy configuration.
Field Xpert SMT50	Universal, high-performance tablet PC for device configuration in non-hazardous areas.

Service-specific accessories

Accessories	Description
Applicator	<p>Software for selecting and sizing Endress+Hauser measuring devices:</p> <ul style="list-style-type: none"> ■ Calculation of all the necessary data for identifying the optimum measuring device: e.g. pressure loss, accuracy or process connections. ■ Graphic illustration of the calculation results <p>Administration, documentation and access to all project-related data and parameters over the entire life cycle of a project.</p> <p>Applicator is available: Via the Internet: https://portal.endress.com/webapp/applicator</p>
Configurator	<p>Product Configurator - the tool for individual product configuration</p> <ul style="list-style-type: none"> ■ Up-to-the-minute configuration data ■ Depending on the device: direct input of information specific to the measuring point, such as the measuring range or operating language ■ Automatic verification of exclusion criteria ■ Automatic creation of the order code and its breakdown in PDF or Excel output format ■ Ability to order directly in the Endress+Hauser Online Shop <p>The Product Configurator is available on the Endress+Hauser website: www.endress.com -> Select your country -> Click "Products" -> Select the product using the filters and search field -> Open product page -> The "Configure" button to the right of the product image opens the Product Configurator.</p>
FieldCare SFE500	<p>FDT-based plant asset management tool from Endress+Hauser. It can configure all smart field units in your system and helps you manage them. By using the status information, it is also a simple but effective way of checking their status and condition.</p> <p> For details, see Operating Instructions BA00027S and BA00065S</p>
DeviceCare SFE100	<p>Configuration tool for devices via fieldbus protocols and Endress+Hauser service protocols.</p> <p>DeviceCare is the tool developed by Endress+Hauser for the configuration of Endress+Hauser devices. All smart devices in a plant can be configured via a point-to-point or point-to-bus connection. The user-friendly menus enable transparent and intuitive access to the field devices.</p> <p> For details, see Operating Instructions BA00027S</p>

Supplementary documentation

The following types of documentation are available on the product pages and in the Download Area of the Endress+Hauser website (www.endress.com/downloads) (depending on the selected device version):

Document	Purpose and content of the document
Technical Information (TI)	<p>Planning aid for your device</p> <p>The document contains all the technical data on the device and provides an overview of the accessories and other products that can be ordered for the device.</p>
Brief Operating Instructions (KA)	<p>Guide that takes you quickly to the 1st measured value</p> <p>The Brief Operating Instructions contain all the essential information from incoming acceptance to initial commissioning.</p>

Document	Purpose and content of the document
Operating Instructions (BA)	<p>Your reference document</p> <p>The Operating Instructions contain all the information that is required in various phases of the life cycle of the device: from product identification, incoming acceptance and storage, to mounting, connection, operation and commissioning through to troubleshooting, maintenance and disposal.</p>
Description of Device Parameters (GP)	<p>Reference for your parameters</p> <p>The document provides a detailed explanation of each individual parameter. The description is aimed at those who work with the device over the entire life cycle and perform specific configurations.</p>
Safety Instructions (XA)	<p>Depending on the approval, Safety Instructions (XA) are supplied with the device. The Safety Instructions are an integral part of the Operating Instructions.</p> <p> Information on the Safety Instructions (XA) that are relevant for the device is provided on the nameplate.</p>
Supplementary device-dependent documentation (SD/FY)	<p>Always comply strictly with the instructions in the relevant supplementary documentation. The supplementary documentation is an integral part of the device documentation.</p>



71619649

www.addresses.endress.com