

Technical Information

Micropilot FWR30

Free space radar



Battery-operated level sensor for monitoring remote and mobile applications

Application

- Ingress protection: IP66/IP68, NEMA Type 4X/6P
- Maximum measuring range: 15 m (49 ft)
- Ambient temperature: -20 to +60 °C (-4 to +140 °F)
- Connectivity: LTE-M, NB-IoT, GPRS, EDGE
- Accuracy: 10 mm (0.39 in)

Your benefits

- Transparency - easy monitoring of liquids and bulk solids
- Flexible and secure integration into cloud platforms, such as Netilion or SupplyCare Hosting
- Easy commissioning and flexible installation
- Reliable 80 GHz radar sensor
- Localization of device using GNSS/GPS technology

Table of contents

About this document	3	Industry Canada	16
Symbols	3	Compliance with the Japanese Radio Law and the Japanese Telecommunication Business Law	16
Function and system design	3	Radiofrequency radiation exposure information	16
Measuring principle	3	Radio approval	16
Input	3	Other standards and guidelines	16
Measured variable	3	Ordering information	17
Measuring range	3	Accessories	17
Operating frequency	4	Supplementary documentation	17
Blocking distance	4	Supplementary device-dependent documentation	17
Sensitivity	5		
Output	5		
Output signal	5		
Protocol-specific data	5		
Power supply	5		
Supply voltage	5		
Performance characteristics	6		
Reference operating conditions	6		
Maximum measured error	6		
Influence of ambient temperature	6		
Installation	7		
Mounting location	7		
Mounting kit	9		
Beam angle	11		
Environment	11		
Ambient temperature	11		
Storage temperature	11		
Relative humidity	11		
Climate class	11		
Operating altitude according to DIN EN 61010-1 Ed. 3 ...	11		
Degree of protection	11		
Vibration and shock resistance	11		
Electromagnetic compatibility	11		
Process	11		
Mechanical construction	12		
Dimensions	12		
Weight	13		
Materials	13		
Operability	14		
Operating concept	14		
Certificates and approvals	14		
CE mark	14		
RoHS	14		
EN 302729-1/2 radio standard	14		
FCC	15		

About this document

Symbols

Safety symbols

DANGER

This symbol alerts you to a dangerous situation. Failure to avoid this situation will result in serious or fatal injury.

WARNING

This symbol alerts you to a dangerous situation. Failure to avoid this situation can result in serious or fatal injury.

CAUTION

This symbol alerts you to a dangerous situation. Failure to avoid this situation can result in minor or medium injury.

NOTICE

This symbol contains information on procedures and other facts which do not result in personal injury.

Symbols for certain types of information

Permitted: 

Procedures, processes or actions that are permitted.

Forbidden: 

Procedures, processes or actions that are forbidden.

Additional information: 

Series of steps: [1.](#), [2.](#), [3.](#)

Symbols in graphics

Item numbers: 1, 2, 3 ...

Views: A, B, C, ...

Function and system design

Measuring principle

The Micropilot is a "downward-looking" measuring system, operating based on the time-of-flight method (ToF). It measures the distance from the reference point to the product surface. Radar pulses are emitted by an antenna, reflected off the product surface and received again by the radar system.

Input

Measured variable

Measured process variables

- **Level:** 0 to 15 m (0 to 49 ft) ±10 mm (0.39 in)
- **Ambient temperature:** -20 to +60 °C (-4 to +140 °F) with an accuracy of ± 2 °C (4 °F)
- **Position:** Angle of device to the horizontal
 - Range: 0 to 180°
 - The position angle can only be measured if the sensor does not move
- **GPS:**
 - ±20 m (66 ft) in free field conditions

Measuring range

Maximum measuring range 0 to 15 m (0 to 49 ft)

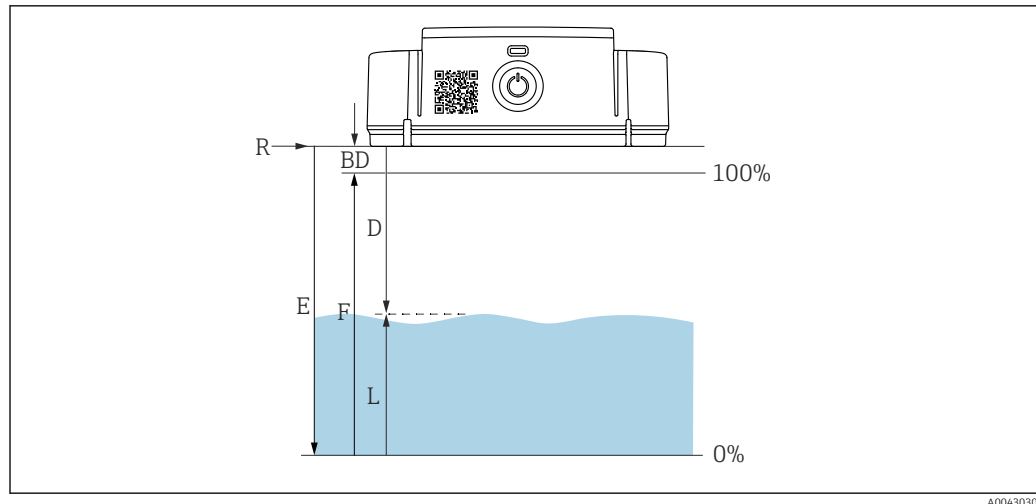

1 Calibration parameter

- E* Empty calibration (= zero)
- F* Full calibration (= span)
- D* Measured distance
- L* Level ($L = E - D$)
- R* Reference point
- BD* Blocking distance

Medium

Information on the nameplate:

- Dev.Rev.1 (Device Revision): liquid applications
- Dev.Rev.2 (Device Revision): liquid and solid applications

Usable measuring range for solid applications

The usable measuring range depends on the reflection properties of the medium, the installation position and possible interference reflections.

i Measurement of the following media with absorbing gas phase

For example:

- Ammonia (pure - 100%)
- Acetone
- Methylene chloride
- Methyl ethyl ketone
- Propylene oxide
- VCM (vinyl chloride monomer)

To measure absorbing gases, either use a guided radar, measuring devices with another measuring frequency or another measuring principle.

If measurements must be performed in one of these media, please contact Endress+Hauser.

Operating frequency

80 GHz

The operating frequency is for measurement purposes only and is not used for communication.

Blocking distance

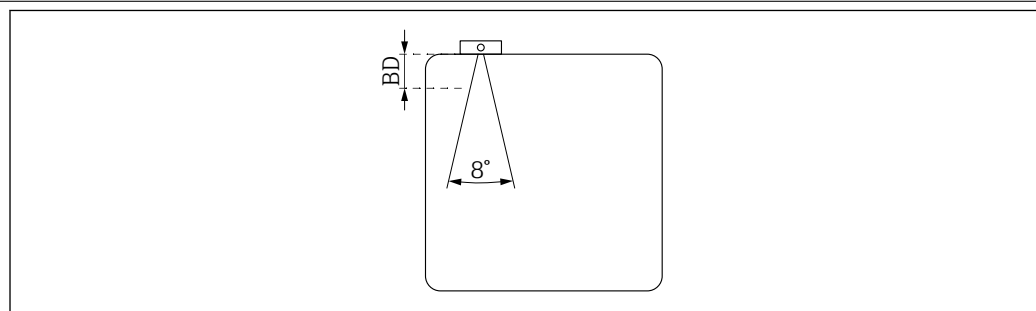

- No signals are analyzed within the blocking distance (BD)
For this reason, the blocking distance can be used to suppress interference signals (e.g. from condensate) near the antenna
- Factory setting: automatic
- The blocking distance (BD) can be defined in the cloud or set automatically
The setting is made in the blocking distance parameter
The following formula is used for the automatic setting:
Empty tank - full tank - 100 mm (3.94 in) = blocking distance (min. 0 mm)

Sensitivity

The sensitivity of the sensor can be configured using a "sensitivity parameter" (high, medium, low).

Output

Output signal

Cellular radio LTE-M, NB-IoT and GPRS, EDGE

- Order code 030 option A: Cellular radio + SIM card (NB-IoT/LTE-M/ GPRS, EDGE)
 - GPRS/EDGE GSM850, E-GSM900, DCS1800, PCS1900
 - 4G LTE-M1 (LTE Cat-M1) LTE-FDD: B2/B3/B4/B5/B8/ /B20/B26 LTE-TDD: B39
 - 4G LTE-NB1 (NB-IoT) LTE-FDD: B2/B3/B8/B20
- Order code 030 option B: GPS + SIM card + cellular radio EU (NB-IoT, LTE-M, GPRS, EDGE) optimized for Europe, Asia, Africa
 - GPRS/EDGE GSM850, E-GSM900, DCS1800, PCS1900
 - 4G LTE-M1 (LTE Cat-M1) LTE-FDD: B1/B2/B3/B4/B5/B8/B20/B26 LTE-TDD:B39
 - 4G LTE-NB1 (NB-IoT) LTE-FDD: B3/B5/B8/B20
- Order code 030 option C: GPS + SIM card +cellular radio US (NB-IoT, LTE-M, GPRS, EDGE) optimized for America, Australia, New Zealand
 - GPRS/EDGE GSM850, DCS1800, PCS1900
 - 4G LTE-M1 (LTE Cat-M1) LTE-FDD: B2/B3/B4/B5/B12/B13/B20/B28 LTE-TDD: B39
 - 4G LTE-NB1 (NB-IoT) LTE-FDD: B2/B4/B12/B13/B28

The cellular radio signal is selected automatically by the device. The selection depends on availability. The priority is 4G (LTE-M1 or LTE-NB1). If neither of the two cellular radio signals is available, the GPRS or EDGE cellular radio signal is selected. The priorities are: LTE-M → GPRS, EDGE → NB-IoT

Transmission interval

The transmission interval can be set between 15 minutes and 24 hours.

The battery life depends on the transmission interval.

-  ▪ In the event of a poor network connection, select a transmission interval > 1 hour
- If GPS is set, the transmission interval is limited to ≥1 hour

Protocol-specific data



The FWR30 uses:

- internet protocol TCP/IP and the secure transport layer TLS (v1.2)
- application layer protocol HTTPS

Power supply

Supply voltage

Replaceable battery, standard size, lithium (D), 3.6 V, 19 Ah (included in the delivery)
Designation in accordance with IEC: ER34615 (primary battery lithium thionyl chloride); product recommendation: Tadiran SL-2880 (Europe), Tadiran TL-4930 (outside Europe)

-  The measuring device determines the battery charge state automatically. The LED flashes red every 10 seconds if the battery charge state is low or critical.
-  The battery status is indicated as full, medium, low or critical.
-  In addition to the recommended battery types Tadiran SL-2880 (Europe), Tadiran TL-4930 (outside Europe), it is also possible to use the battery type Tadiran SL-2870 (Europe) or Tadiran TL-5930 (outside Europe). The indicated battery lives can differ in this case, however.

Safety notice for the device battery**⚠ CAUTION****Risk of fire or burns if the device battery is handled incorrectly!**

- ▶ Do not charge or open the battery, expose it to fire or heat it above 100 °C (212 °F).
- ▶ Only replace the battery with a ER34615 battery (lithium-thionyl chloride primary battery, size D). The use of any other battery can present a fire or explosion hazard.
- ▶ Dispose of the used battery immediately as per national regulations.
- ▶ Keep used batteries out of the reach of children. Do not open used batteries or expose them to fire.

Replacement battery

For use in North America: The replacement battery must have CSA/UL approval.

Battery life**Measuring interval 8 h**

Transmission interval 8 h: battery life > 8 years

Measuring interval 6 h

Transmission interval 12 h: battery life > 10 years

Measuring interval 1 h

- Transmission interval 24 h: battery life > 10 years
- Transmission interval 4 h: battery life > 5 years
- Transmission interval 1 h: battery life approx. 500 days

Measuring interval 1 min

- Transmission interval 1 h: battery life approx. 400 days
- Transmission interval 15 min: battery life approx. 140 days
- Transmission interval < 1 h: cannot be set for GPS operation



- Calculation only applies to Tadiran SL-2880 battery (Europe), Tadiran TL-4930 battery (outside Europe), at approx. +25 °C (+77 °F)
 - A strong cellular radio signal is required
 - The actual battery life can vary greatly and depends on a number of factors including the network provider, temperature or humidity
 - High transmission rates reduce the battery life
 - Transmission intervals < 1 h have a considerable impact on the battery life
 - Calculation applies to operation without GPS. If GPS localization is performed in free field conditions during each transmission, the battery life is halved.

Performance characteristics**Reference operating conditions**

- Temperature = +24 °C (+75 °F) ±5 °C (±9 °F)
- Pressure = 960 mbar abs. (14 psia) ±100 mbar (±1.45 psi)
- Humidity = 60 % ±15 %
- Reflector: metal plate with a diameter ≥ 1 m (40 in)
- No major interference reflections inside the signal beam

Maximum measured error

Accuracy: ±10 mm (0.39 in) within the entire measuring range



- If the setting is **Medium type = Solid**, the devices are optimized for solids applications when delivered from the factory. The additional reference condition for accuracy is the setting **Medium type = Liquid**.

Influence of ambient temperature

Temperature coefficient: ≤ 4 mm (0.16 in) per 10 K

Installation

Mounting location

The device can be mounted indoors or outdoors.

Mounting on metal vessels and silos with threaded adapter

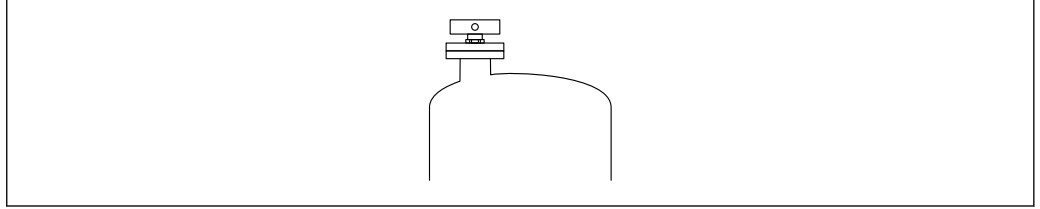

A0045526

2 Silo with threaded adapter

Threaded adapter

- G 1½" (process pressure max. 4 bar abs. (58 psi))
- MNPT 1½" (process pressure max. 4 bar abs. (58 psi))

Mounting instructions

- Mount the measuring device in a horizontal position so that it is parallel to the tank ceiling. Otherwise, undesired reflections from the surroundings can cause interference signals.
- The radar antenna should never be covered by metal objects.
- Do not mount any objects which may cause interference, such as tank internal fittings, grids or agitators, below or in the direct vicinity of the radar (see the graphic below).

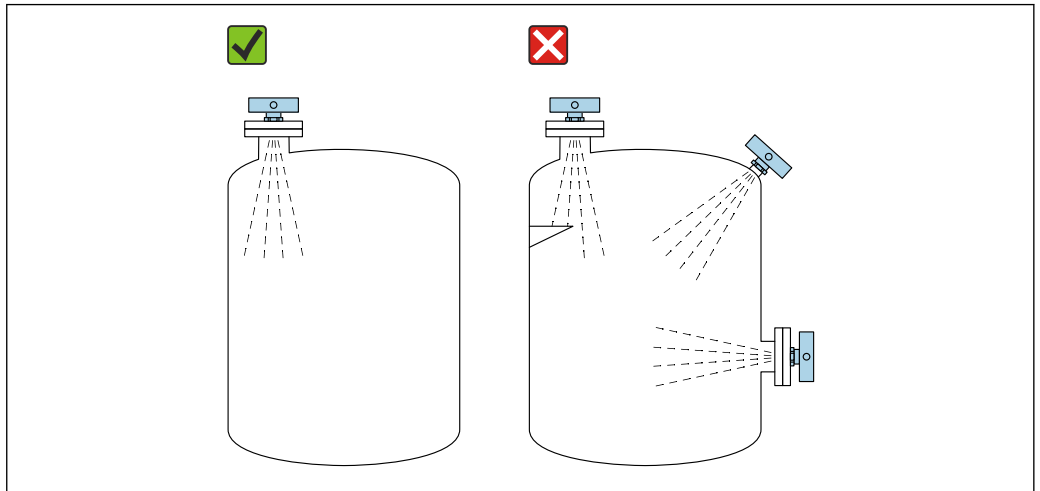

A0045540

Maximum nozzle height and distance to wall

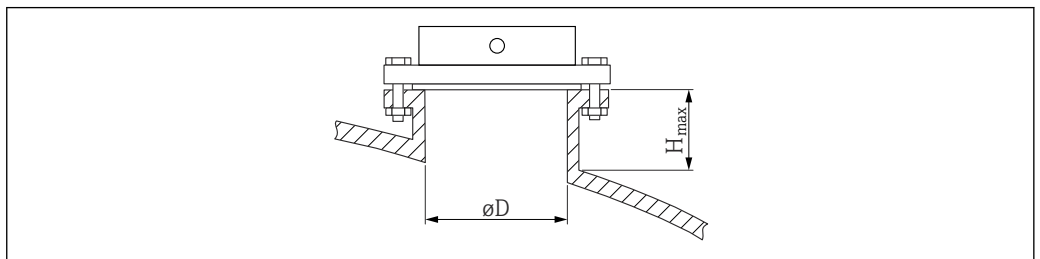

A0046856

Diameter D [mm]	H _{max} [mm]	Measuring distance [mm]	Radiation width ¹⁾ [mm]
40	230	500	70
50	300	1000	140
80	520	2000	280
100	660	5000	699
150	1020	10000	1399

1) The beam angle is 8°.

Mounting on vertical pipes

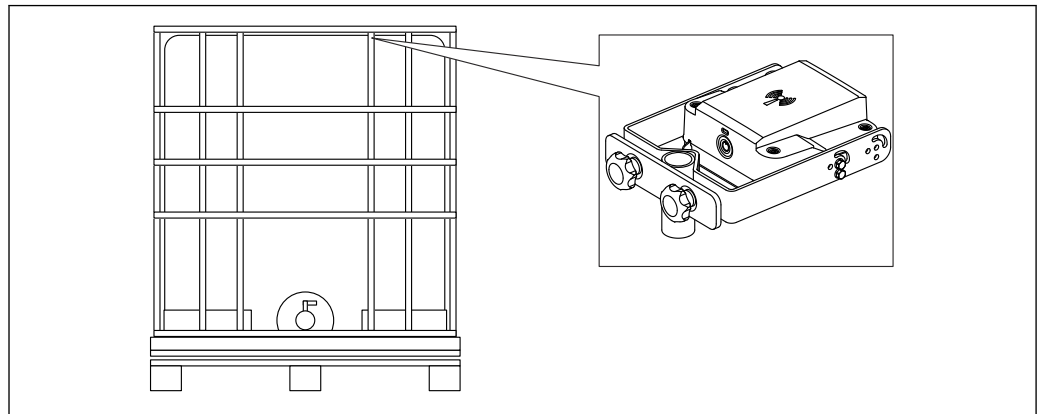

A0040689

3 Mounting with mounting bracket pipe/IBC

Mounting on non-conductive plastic IBC tanks with tubular cage or mesh frame

Mounting with "mounting bracket pipe/IBC".

The mounting bracket pipe/IBC is also suitable for IBC tanks with mesh.

Mounting instructions

- Mount the measuring device in a horizontal position so that it is parallel to the tank ceiling. Otherwise, undesired reflections from the surroundings can cause interference signals.
- The radar antenna should never be covered by metal objects.
- If mounting outdoors, do not mount on a depression of the IBC tank. Water can collect and interfere with the measurement. The measuring device may not stand in water.
- Do not mount any objects which may cause interference, such as tank internal fittings, grids or agitators, below or in the direct vicinity of the radar (see the graphic below).

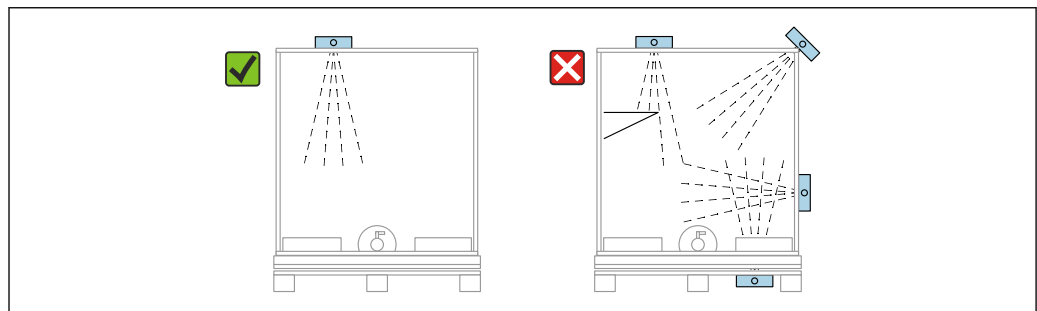

A0043048

Mounting on ceilings or walls

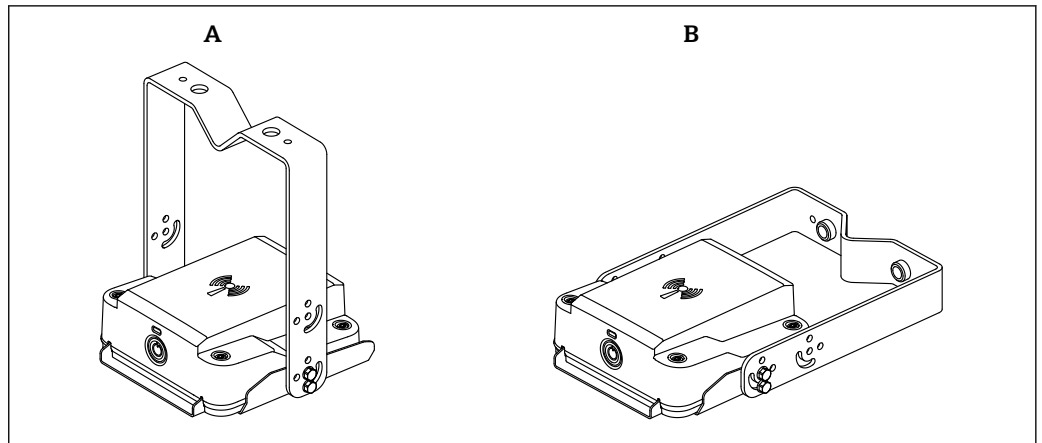

A0040688

- A *Mounting on the ceiling*
- B *Mounting on the wall*

Individual installation

The measuring device can also be installed without using the two mounting brackets. An individual bracket can be attached to the underside using the screw thread. Both mounting kits available include the same base plate, which makes other custom installations possible. If the radar antenna is covered by metal objects, the measuring signal will be distorted.

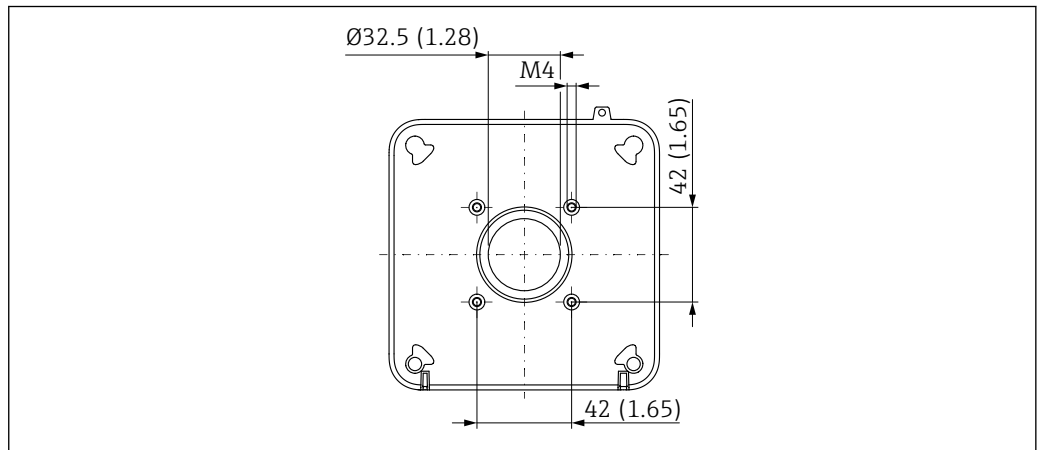

A0041312

Unit of measurement mm (in)

Mounting kit

Pipe/IBC mounting kit

Mounting bracket IBC/pipe

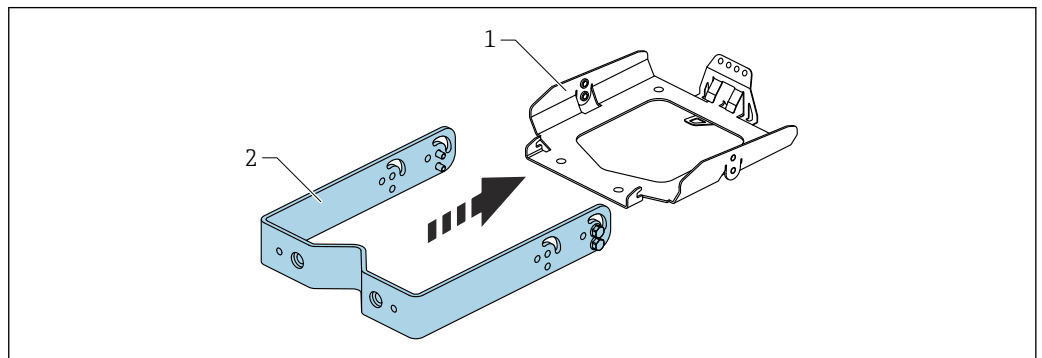

A0040718

The IBC base holder (2) is attached to the adapter plate (1).

The base holder (2) can be mounted on struts with a diameter of 15 to 30 mm (0.59 to 1.18 in) and on square pipes.

IBC mesh-frame adapter

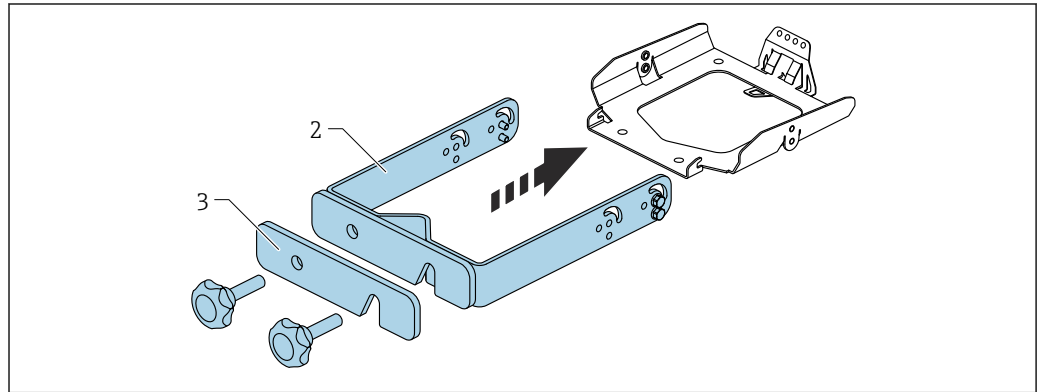

A0040719

The IBC mesh-frame adapter (3) is attached to the IBC base holder (2).

Mounting the FWR30 on the adapter plate

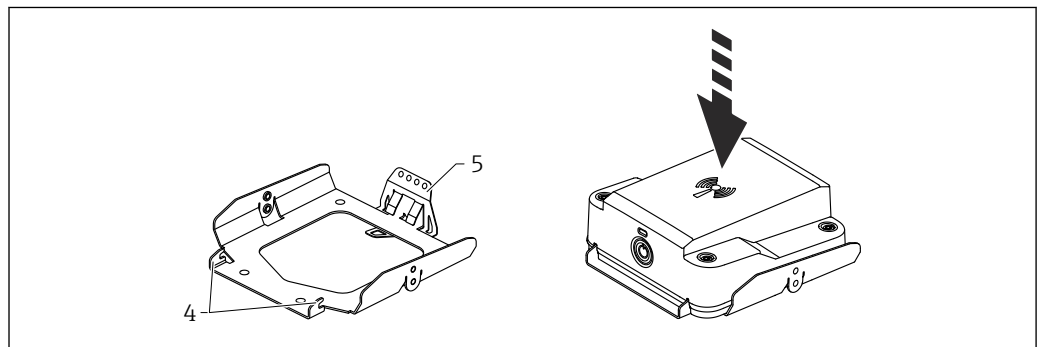

A0040715

1. The hooks (4) and spring (5) are used to fix the FWR30 in the adapter plate.
2. The spring (5) is used to release the FWR30 from the adapter plate.

Wall/ceiling mounting kit

Mounting bracket

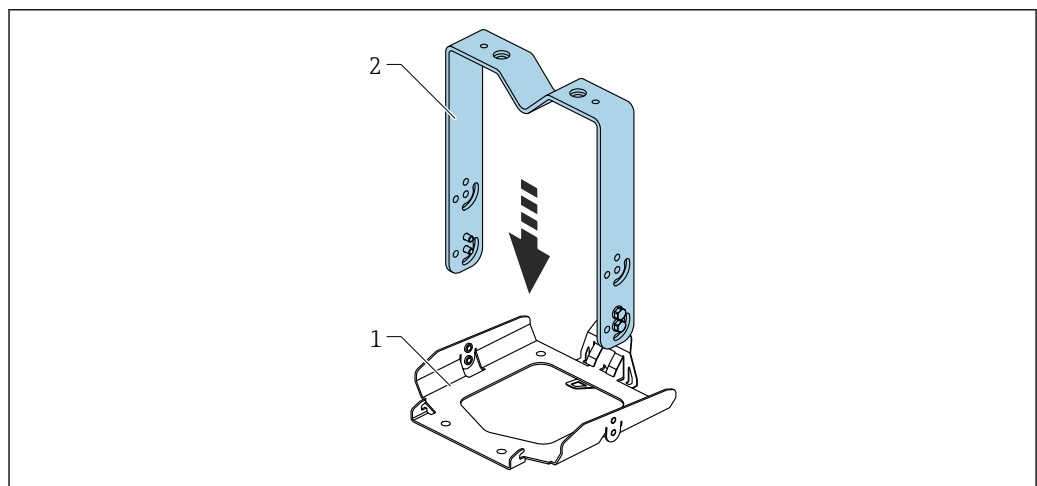

A0040720

The mounting bracket (2) is attached to the adapter plate (1).

Mounting the FWR30 on the adapter plate

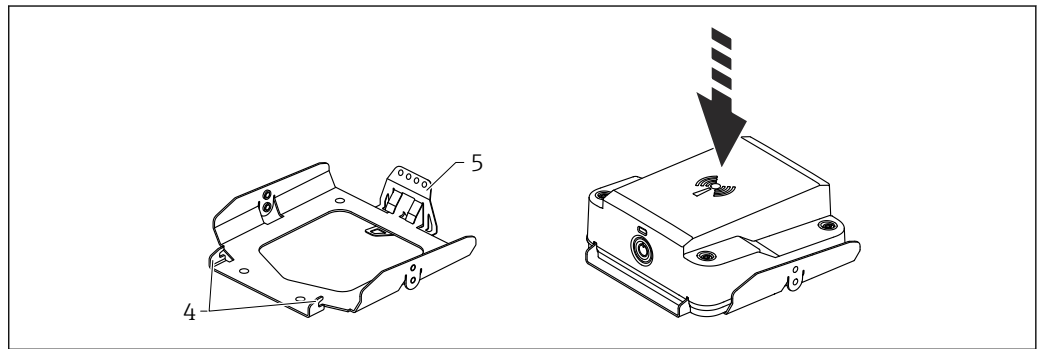

1. The hooks (4) and spring (5) are used to fix the FWR30 in the adapter plate.
2. The spring (5) is used to release the FWR30 from the adapter plate.

Beam angle 8°

Environment

Ambient temperature	-20 to +60 °C (-4 to +140 °F)
Storage temperature	-20 to +60 °C (-4 to +140 °F) Battery discharge is at its lowest if the battery is stored at temperatures from 0 to +30 °C (+32 to +86 °F).
Relative humidity	0 to 95%
Climate class	DIN EN 60068-2-38/IEC 68-2-38: test Z/AD
Operating altitude according to DIN EN 61010-1 Ed. 3	Up to 2 000 m (6 600 ft) above sea level.
Degree of protection	IP66, IP68, NEMA Type 4X/6P
Vibration and shock resistance	In accordance with DIN EN 60068-2-27 / IEC 60068-2-27 / DIN EN 60068-2-64: 18 ms, 30g, half-sine
Electromagnetic compatibility	In accordance with IEC/EN 61326-1

Process

- Measurement directly through the tank (electrically non-conductive tank walls). No contact is made with the process medium.
- Measurement in the tank with a G1½" threaded adapter: process pressure max. 4 bar abs. (58 psi).
- Measurement in the tank with an MNPT1½" threaded adapter: process pressure max. 4 bar abs. (58 psi).

Mechanical construction

i For the dimensions, see the Product Configurator: www.endress.com

Search for product → click "Configuration" to the right of the product image → after configuration click "CAD"

The following dimensions are rounded values. For this reason, they may deviate slightly from the dimensions given on www.endress.com.

Dimensions

Housing

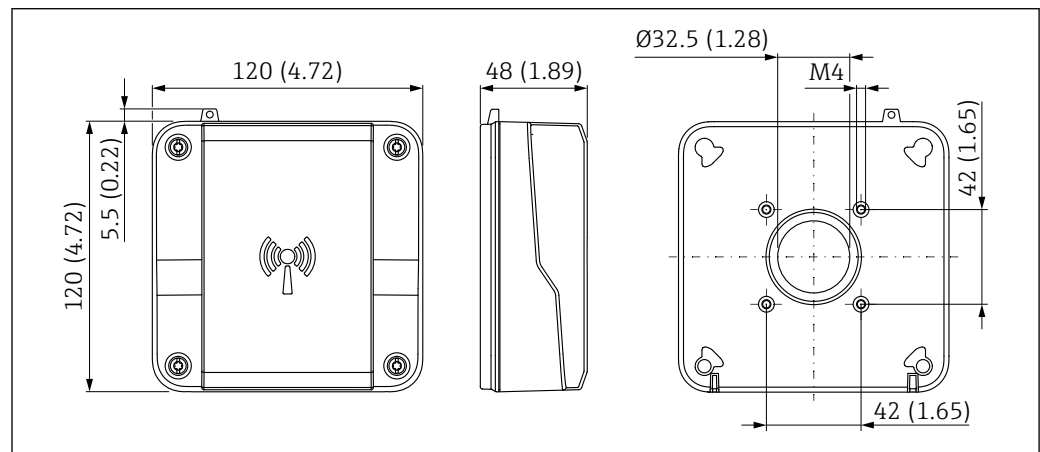

A0040969

Unit of measurement mm (in)

Accessories

Mounting bracket pipe/IBC

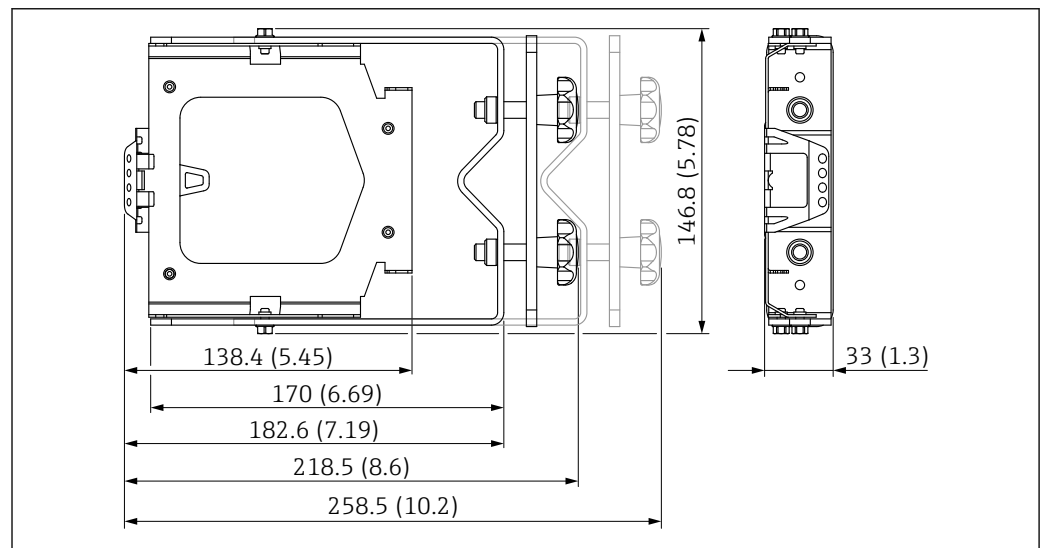

A0040971

Unit of measurement mm (in)

Mounting bracket wall/ceiling

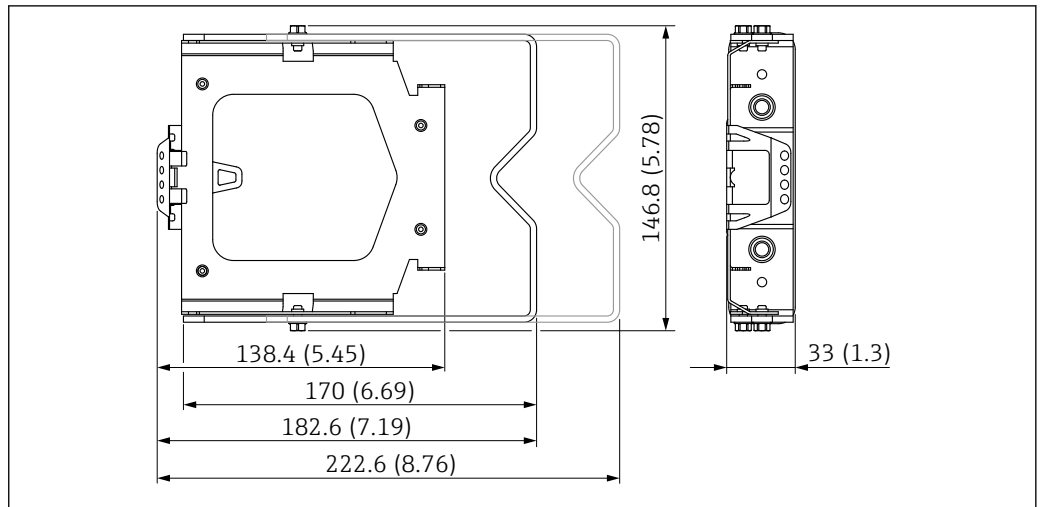

A0040970

Unit of measurement mm (in)

Adapter

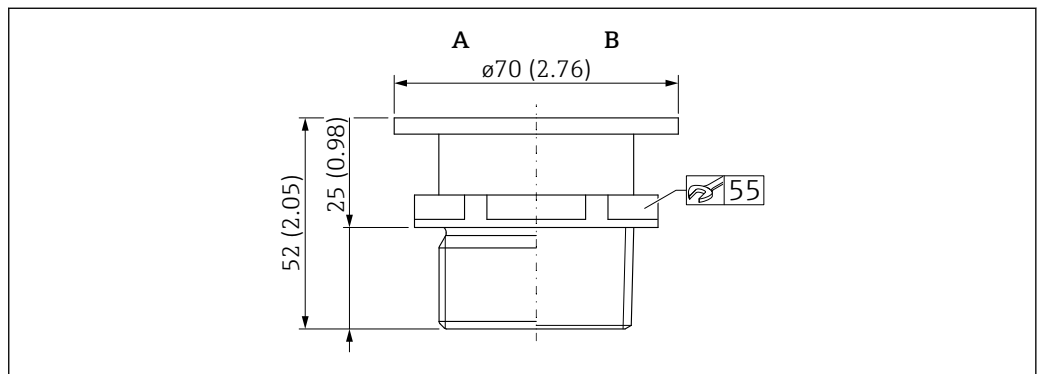

A0045480

Unit of measurement mm (in)

- A G 1½" adapter, process seal: EPTM
- B MNPT 1½" adapter

Weight

Housing

- Weight with original battery: 0.5 kg (1.1 lb)
- Weight without battery: 0.4 kg (0.88 lb)

Accessories

- Mounting bracket pipe/IBC: 860 g (30.33 oz)
- Mounting bracket wall/ceiling: 450 g (15.87 oz)
- G 1½" adapter: 300 g (10.581 oz)
- MNPT 1½" adapter: 300 g (10.581 oz)

Materials

Housing

- Plastic PBT/PC
- Seal: TPE

Radar antenna

Plastic PBT/PC

Accessories

- Mounting bracket pipe/IBC: AISI316 L (1.4404)
- Mounting bracket universal: AISI316 L (1.4404)
- G 1½" adapter: AISI316 L (1.4404)
- MNPT 1½" adapter: AISI316 L (1.4404)
- Process seal: EPTM

Operability

Operating concept

- Straightforward operation without wiring
- Configuration via cloud using Web application, e.g. Netilion Value, Netilion Inventory or SupplyCare Hosting
- Connection status displayed via LED
- Third-party applications can be implemented via an API interface with Netilion Connect

Certificates and approvals

-  The certificates and approvals currently available can be accessed via the Product Configurator.
 - FCC is not yet available for the GPS version.
 - Canada CNR-Gen is not yet available for the GPS version.
 - Radiofrequency radiation exposure information is not yet available for the GPS version.

CE mark

The measuring system meets the legal requirements of the applicable EU directives. These are listed in the corresponding EU Declaration of Conformity together with the standards applied.

The manufacturer confirms successful testing of the device by affixing to it the CE mark.

RoHS

The measuring system meets the substance restrictions of the Directive on the Restriction of the Use of Certain Hazardous Substances 2011/65/EU (RoHS 2) and the Delegated Directive (EU) 2015/863 (RoHS 3).

EN 302729-1/2 radio standard

The devices comply with the LPR (Level Probing Radar) radio standard EN 302729-1/2 and are approved for unrestricted use inside and outside of closed vessels in countries of the EU and EFTA. As a prerequisite, the countries in question must have already implemented this standard.

The following countries are those that have currently implemented the standard:

Belgium, Bulgaria, Germany, Denmark, Estonia, France, Greece, UK, Ireland, Iceland, Italy, Liechtenstein, Lithuania, Latvia, Malta, The Netherlands, Norway, Austria, Poland, Portugal, Romania, Sweden, Switzerland, Slovakia, Spain, Czech Republic and Cyprus.

Implementation is still underway in all of the countries not listed.

Please note the following for operation of the devices outside of closed vessels:

1. The device must be mounted in accordance with the instructions in the "Installation" section.
2. Installation must be carried out by properly trained, expert staff.
3. The device antenna must be installed in a fixed location pointing vertically downwards.
4. The installation site must be located at a distance of 4 km from the astronomy stations listed below or otherwise approval must be provided by the relevant authority. If the device is installed at a distance of 4 to 40 km from one of the listed stations, it must not be installed at a height of more than 15 m (49 ft) above the ground.

Astronomy stations

Country	Name of the station	Latitude	Longitude
Germany	Effelsberg	50°31'32" North	06°53'00" East
Finland	Metsähovi	60°13'04" North	24°23'37" East

Country	Name of the station	Latitude	Longitude
	Tuorla	60°24'56" North	24°26'31" East
France	Plateau de Bure	44°38'01" North	05°54'26" East
	Floirac	44°50'10" North	00°31'37" West
Great Britain	Cambridge	52°09'59" North	00°02'20" East
	Damhall	53°09'22" North	02°32'03" West
	Jodrell Bank	53°14'10" North	02°18'26" West
	Knockin	52°47'24" North	02°59'45" West
	Pickmere	53°17'18" North	02°26'38" West
Italy	Medicina	44°31'14" North	11°38'49" East
	Noto	36°52'34" North	14°59'21" East
	Sardinia	39°29'50" North	09°14'40" East
Poland	Fort Skala Krakow	50°03'18" North	19°49'36" East
Russia	Dmitrov	56°26'00" North	37°27'00" East
	Kalyazin	57°13'22" North	37°54'01" East
	Pushchino	54°49'00" North	37°40'00" East
	Zelenchukskaya	43°49'53" North	41°35'32" East
Sweden	Onsala	57°23'45" North	11°55'35" East
Switzerland	Bleien	47°20'26" North	08°06'44" East
Spain	Yebes	40°31'27" North	03°05'22" West
	Robledo	40°25'38" North	04°14'57" West
Hungary	Penc	47°47'22" North	19°16'53" East



As a general rule, the requirements outlined in EN 302729-1/2 must be observed.

FCC

- Order code 030 option A, cellular radio + SIM card (NB-IoT/LTE-M/ GPRS, EDGE):
FCC ID: LCGFWR3XWEL includes transmitter module FCC ID:XMR201707BG96
- Order code 030 option B, GPS + SIM card + cellular radio EU (NB-IoT, LTE-M, GPRS, EDGE)
Is not FCC-certified
- Order code 030 option C, GPS + SIM card +cellular radio US (NB-IoT, LTE-M, GPRS, EDGE)
FCC ID: LCGFWR3XXEL

This device complies with Part 15 of the FCC rules. Operation is subject to the following two conditions: (1) This device must not cause harmful interference, and (2) this device must accept any interference received, including interference that may cause undesired operation.

[Any] changes or modifications not expressly approved by the party responsible for compliance could void the user's authority to operate the equipment.

The devices are compliant with the FCC Code of Federal Regulations, CFR 47, Part 15, Sections 15.205, 15.207, 15.209.

In addition, the devices are compliant with Section 15.256 . For these LPR (Level Probe Radar) applications the devices must be professionally installed in a downward operating position. In addition, the devices must not be mounted in a zone of 4 km around RAS stations and within a radius of 40 km around RAS stations. The maximum operating height of devices is 15 m (49 ft) above ground.

The GNSS receiver is compliant with the FCC Code of Federal Regulations, CFR 47, Part 15, Sections 15.107, 15.109.

Industry Canada

- Order code 030 option A, cellular radio + SIM card (NB-IoT/LTE-M/ GPRS, EDGE):
Model FWR30 IC ID: 2519A-WEL includes transmitter module IC ID: 10224A-201709BG96
- Order code 030 option B, GPS + SIM card + cellular radio EU (NB-IoT, LTE-M, GPRS, EDGE)
Is not IC-certified
- Order code 030 option C, GPS + SIM card +cellular radio US (NB-IoT, LTE-M, GPRS, EDGE)
Model FWR30-C IC ID: 2519A-XEL

Canada CNR-Gen Section 7.1.3

This device complies with Industry Canada licence-exempt RSS standard(s). Operation is subject to the following two conditions: (1) This device must not cause harmful interference, and (2) this device must accept any interference, including interference that may cause undesired operation of the device.

Le présent appareil est conforme aux CNR d'Industrie Canada applicables aux appareils radio exempts de licence. L'exploitation est autorisée aux deux conditions suivantes: (1) l'appareil ne doit pas produire de brouillage, et (2) l'utilisateur de l'appareil doit accepter tout brouillage radioélectrique subi, même si le brouillage est susceptible d'en compromettre le fonctionnement.

[Any] changes or modifications not expressly approved by the party responsible for compliance could void the user's authority to operate the equipment.

Includes transmitter module IC ID: 10224A-201709BG96

- The installation of the LPR/TLPR device shall be done by trained installers, in strict compliance with the manufacturer's instructions.
- The use of this device is on a "no-interference, no-protection" basis. That is, the user shall accept operations of high-powered radar in the same frequency band, which may interfere with or damage this device. However, devices found to interfere with primary licensing operations will be required to be removed at the user's expense.
- This device shall be installed and operated in a completely enclosed container to prevent RF emissions, which can otherwise interfere with aeronautical navigation.
- The installer/user of this device shall ensure that it is at least 10 km from the Dominion Astrophysical Radio Observatory (DRAO) near Penticton, British Columbia. The coordinates of the DRAO are latitude 49°19'15" N and longitude 119°37'12" W. For devices not meeting this 10 km separation (e.g., those in the Okanagan Valley, British Columbia,) the installer/user must coordinate with, and obtain the written concurrence of, the Director of the DRAO before the equipment can be installed or operated. The Director of the DRAO may be contacted at 250-497-2300 (tel.) or 250-497-2355 (fax). (Alternatively, the Manager, Regulatory Standards Industry Canada, may be contacted.)



The model FWR30 fulfills the requirements for use as LPR (Level Probe Radar).

Compliance with the Japanese Radio Law and the Japanese Telecommunication Business Law

The measuring device is approved according to the Japanese Radio Law (電波法) and the Japanese Telecommunication Business Law (電気通信事業法). The measuring device may not be modified (otherwise the assigned designation number is invalid).

Radiofrequency radiation exposure information

This equipment complies with FCC and IC radiation exposure limits set forth for an uncontrolled environment. This equipment should be installed and operated with minimum distance of 20 cm between the radiator and your body. This transmitter must not be co-located or operating in conjunction with any other antenna or transmitter.

Cet équipement est conforme aux limites d'exposition aux rayonnements IC établies pour un environnement non contrôlé. Cet équipement doit être installé et utilisé avec un minimum de 20 cm de distance entre la source de rayonnement et votre corps. Ce transmetteur ne doit pas être placé au même endroit ou utilisé simultanément avec un autre transmetteur ou antenne.

Radio approval

- Order code for 030 option A: Cellular radio: RED conformity and FCC/IC approval
- Order code for 030 option B: Cellular radio and GPS: RED conformity
- Order code for 030 option C: Cellular radio and GPS: FCC/IC approval

Other standards and guidelines

- EN 61010-1
- EN 61326-1 EMC

Ordering information

Detailed ordering information is available for your nearest sales organization www.addresses.endress.com or in the Product Configurator under www.endress.com :

1. Click Corporate
2. Select the country
3. Click Products
4. Select the product using the filters and search field
5. Open the product page

The Configuration button to the right of the product image opens the Product Configurator.



Product Configurator - the tool for individual product configuration

- Up-to-the-minute configuration data
- Depending on the device: Direct input of measuring point-specific information such as measuring range or operating language
- Automatic verification of exclusion criteria
- Automatic creation of the order code and its breakdown in PDF or Excel output format
- Ability to order directly in the Endress+Hauser Online Shop

Accessories

- Mounting bracket pipe/IBC
- Mounting bracket wall/ceiling
- G 1½" adapter
- MNPT 1½" adapter

Supplementary documentation



- For an overview of the scope of the associated Technical Documentation, refer to the following:
- *Device Viewer* (www.endress.com/deviceviewer): Enter the serial number from the nameplate
 - *Endress+Hauser Operations app*: Enter serial number from nameplate or scan matrix code on nameplate.

Supplementary device-dependent documentation

Additional documents are supplied depending on the device version ordered: Always comply strictly with the instructions in the supplementary documentation. The supplementary documentation is an integral part of the device documentation.



71581324

www.addresses.endress.com
