



IFC 070 Handbook

Electromagnetic signal converter

Electronic Revision ER 4.0.0_

The documentation is only complete when used in combination with the relevant documentation for the sensor.

All rights reserved. It is prohibited to reproduce this documentation, or any part thereof, without the prior written authorisation of KROHNE Messtechnik GmbH.

Subject to change without notice.

Copyright 2009 by
KROHNE Messtechnik GmbH - Ludwig-Krohne-Str. 5 - 47058 Duisburg (Germany)

1	Safety instructions	5
1.1	Software versions	5
1.2	Intended use	5
1.3	Transportation, handling and using instruction for batteries	6
1.4	Safety instructions from the manufacturer	6
1.4.1	Copyright and data protection	6
1.4.2	Disclaimer	7
1.4.3	Product liability and warranty	8
1.4.4	Information concerning the documentation	8
1.4.5	Warnings and symbols used	9
1.5	Safety instructions for the operator	9
2	Device description	10
2.1	Instrument description	10
2.2	Scope of delivery	10
2.3	Nameplate	11
3	Installation	12
3.1	Notes on installation	12
3.2	Storage	12
3.3	Transport	12
3.4	Pre-installation requirements	12
3.5	Installation requirements	13
3.5.1	Vibration	13
3.5.2	Magnetic field	13
3.5.3	Installation of converter	13
4	Electrical connections	14
4.1	Safety instructions	14
4.2	Grounding	14
4.3	Signal cable	14
4.4	Connection of signal cable	15
4.5	Terminal assignment of converter	16
5	Start-up	17
5.1	Connection of battery	17
5.1.1	Internal battery	17
5.1.2	External battery	17
6	Operation	19
6.1	Display and operating elements	19
6.2	Menu of converter	19

7 Service	24
<hr/>	
7.1 Replacement of battery	24
7.1.1 Replacement of internal battery.....	24
7.1.2 Replacement of external battery.....	25
7.2 Spare parts availability	26
7.3 Availability of services	26
7.4 Returning the device to the manufacturer.....	26
7.4.1 General information.....	26
7.4.2 Form (for copying) to accompany a returned device.....	28
7.5 Disposal	28
8 Technical data	29
<hr/>	
8.1 Measuring principle.....	29
8.2 Technical data.....	30
8.3 Measuring accuracy	33
8.4 Dimensions and weights	33
9 Notes	34
<hr/>	

1.1 Software versions

For all GDC devices, the "Electronic Revision" (ER) is consulted to document the revision status of the electronics according to NE 53. It is easy to see from the ER whether any fault repairs or major changes to the electronic equipment have taken place and what effect they have had on compatibility.

Changes and effect on compatibility

1	Downwards compatible changes and fault repair with no effect on operation (e.g. spelling mistakes on display)
3- P S X	Downwards compatible hardware and/or software change of inputs and outputs:
	Pulse output
	Status output
4	all inputs and outputs
4	Downwards compatible changes with new functions
5	Incompatible changes, i.e. electronic equipment must be changed.

Release date	Electronic revision	Changes and compatibility	Documentation
2009	ER2.3.1_ (SW. REV. 2.3.1_)	Initial software version	MA IFC 070 R01
2009	ER4.0.0_ (SW. REV. 4.0.4_)	1; 3-P; 3-S; 4	MA IFC 070 R02



CAUTION!

The OPTIFLUX 2070 and the WATERFLUX 3070 are different instruments with different software. The difference lies in the Electronic Revision number, which can be found on a sticker on the IFC 070 electronics. The electronics are therefore not compatible with each other!

1.2 Intended use

This signal converter IFC 070 has been designed to be combined with a WATERFLUX 3000 water meter or with an OPTIFLUX 2000 flow sensor, for measuring potable water and water with suspended particles.

This device features not only accurate flow measurement, but also continuous diagnostics in accordance with applicable standards. This self-diagnosis monitors and automatically reports improper functioning of the electronics, or faulty sensor electrodes. It reports battery charge condition and even provides a cable-break alarm.

1.3 Transportation, handling and using instruction for batteries

**WARNING!**

The used lithium batteries are primary power sources with high energy content. If mistreated, they may present a potential risk.

**INFORMATION!**

The manufacturer assumes no liability for customer failure.

Please observe the following transportation, handling and using instructions:

- Transport only in special packaging with special labels and transportation documents.
- Do not short-circuit, recharge, overcharge or connect with false polarity.
- Do not expose to temperature beyond the specified temperature range or incinerate the battery.
- Do not crush, puncture or open cells or disassemble battery packs.
- Do not weld or solder to the body of the battery.
- Do not expose contents of battery to water.
- Remove the battery from device before returning to the manufacturer for service or warranty reasons.
- Dispose battery packs in accordance with local regulations; where possible, recycle used batteries.

1.4 Safety instructions from the manufacturer

1.4.1 Copyright and data protection

The contents of this document have been created with great care. Nevertheless, we provide no guarantee that the contents are correct, complete or up-to-date.

The contents and works in this document are subject to German copyright. Contributions from third parties are identified as such. Reproduction, processing, dissemination and any type of use beyond what is permitted under copyright requires written authorisation from the respective author and/or the manufacturer.

The manufacturer tries always to observe the copyrights of others, and to draw on works created in-house or works in the public domain.

The collection of personal data (such as names, street addresses or e-mail addresses) in the manufacturer's documents is always on a voluntary basis whenever possible. Whenever feasible, it is always possible to make use of the offerings and services without providing any personal data.

We draw your attention to the fact that data transmission over the Internet (e.g. when communicating by e-mail) may involve gaps in security. It is not possible to protect such data completely against access by third parties.

We hereby expressly prohibit the use of the contact data published as part of our duty to publish an imprint for the purpose of sending us any advertising or informational materials that we have not expressly requested.

1.4.2 Disclaimer

The manufacturer will not be liable for any damage of any kind by using its product, including, but not limited to direct, indirect, incidental, punitive and consequential damages.

This disclaimer does not apply in case the manufacturer has acted on purpose or with gross negligence. In the event any applicable law does not allow such limitations on implied warranties or the exclusion of limitation of certain damages, you may, if such law applies to you, not be subject to some or all of the above disclaimer, exclusions or limitations.

Any product purchased from the manufacturer is warranted in accordance with the relevant product documentation and our Terms and Conditions of Sale.

The manufacturer reserves the right to alter the content of its documents, including this disclaimer in any way, at any time, for any reason, without prior notification, and will not be liable in any way for possible consequences of such changes.

1.4.3 Product liability and warranty

The operator shall bear responsibility for the suitability of the device for the specific purpose. The manufacturer accepts no liability for the consequences of misuse by the operator. Improper installation and operation of the devices (systems) will cause the warranty to be void. The respective "Standard Terms and Conditions" which form the basis for the sales contract shall also apply.

1.4.4 Information concerning the documentation

To prevent any injury to the user or damage to the device it is essential that you read the information in this document and observe applicable national standards, safety requirements and accident prevention regulations.

If this document is not in your native language and if you have any problems understanding the text, we advise you to contact your local office for assistance. The manufacturer can not accept responsibility for any damage or injury caused by misunderstanding of the information in this document.

This document is provided to help you establish operating conditions, which will permit safe and efficient use of this device. Special considerations and precautions are also described in the document, which appear in the form of underneath icons.

1.4.5 Warnings and symbols used

Safety warnings are indicated by the following symbols.



DANGER!

This information refers to the immediate danger when working with electricity.



DANGER!

This warning refers to the immediate danger of burns caused by heat or hot surfaces.



DANGER!

These warnings must be observed without fail. Even partial disregard of this warning can lead to serious health problems and even death. There is also the risk of seriously damaging the device or parts of the operator's plant.



WARNING!

Disregarding this safety warning, even if only in part, poses the risk of serious health problems. There is also the risk of damaging the device or parts of the operator's plant.



CAUTION!

Disregarding these instructions can result in damage to the device or to parts of the operator's plant.



INFORMATION!

These instructions contain important information for the handling of the device.



LEGAL NOTICE!

This note contains information on statutory directives and standards.



• **HANDLING**

This symbol designates all instructions for actions to be carried out by the operator in the specified sequence.

➔ **RESULT**

This symbol refers to all important consequences of the previous actions.

1.5 Safety instructions for the operator



WARNING!

*In general, devices from the manufacturer may only be installed, commissioned, operated and maintained by properly trained and authorized personnel.
This document is provided to help you establish operating conditions, which will permit safe and efficient use of this device.*

2.1 Instrument description

Two versions are available. You received a compact version or a remote version.

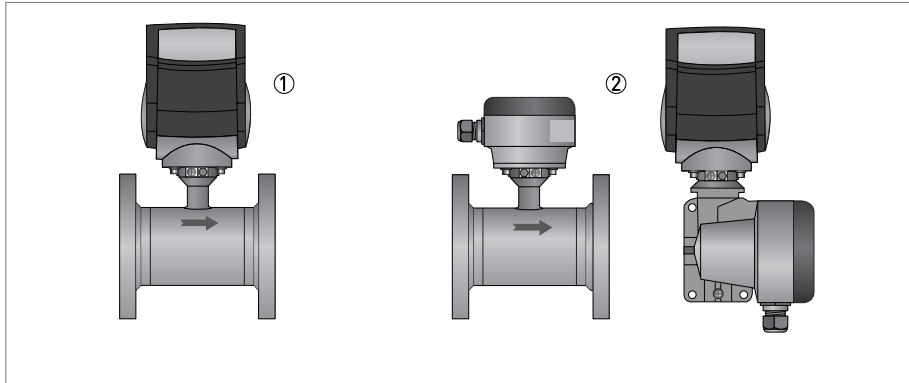

Figure 2-1: Versions

- ① compact version
- ② remote version

2.2 Scope of delivery

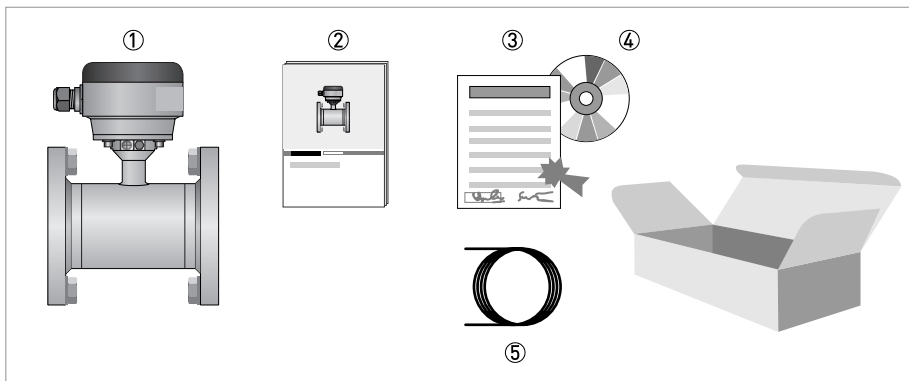

Figure 2-2: Scope of delivery

- ① Ordered flowmeter
- ② Quick Start
- ③ Factory calibration report
- ④ CD-ROM with product documentation
- ⑤ Cable (remote versions only)

2.3 Nameplate



INFORMATION!

Look at the device nameplate to ensure that the device is delivered according to your order. Check for the correct supply voltage printed on the nameplate.

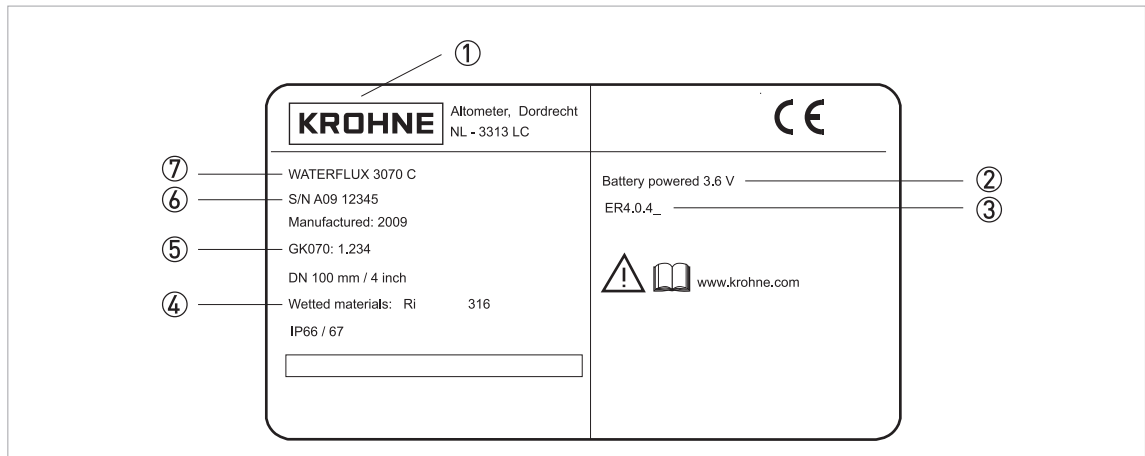

Figure 2-3: Example for nameplate

- ① Manufacturer
- ② Voltage information
- ③ Electronic Revision number
- ④ Material of wetted parts
- ⑤ Meter constant
- ⑥ Serial number
- ⑦ Device type

3.1 Notes on installation

**INFORMATION!**

Inspect the cartons carefully for damage or signs of rough handling. Report damage to the carrier and to the local office of the manufacturer.

**INFORMATION!**

Check the packing list to check if you received completely all that you ordered.

**INFORMATION!**

Look at the device nameplate to ensure that the device is delivered according to your order. Check for the correct supply voltage printed on the nameplate.

3.2 Storage

- Store the device in a dry, dust-free location.
- Avoid continuous direct sunlight.
- Store the device in its original packaging.
- Storage temperature: -50 ...+70°C / -58...+158°F

3.3 Transport

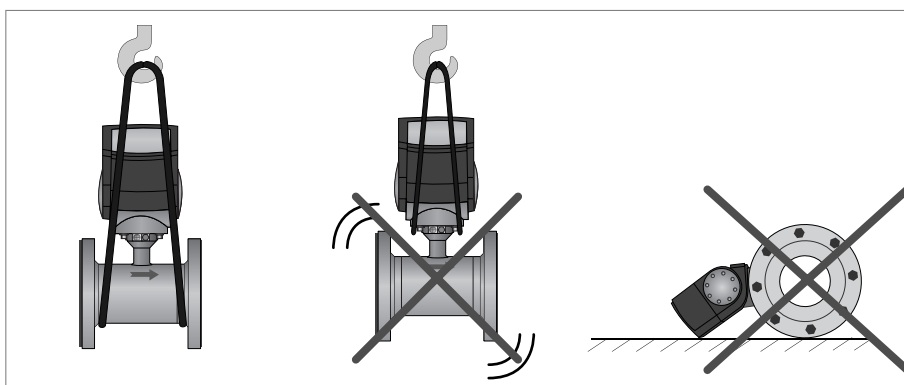

Figure 3-1: Transport

3.4 Pre-installation requirements

Make sure that you have all necessary tools available:

- Allen key (4 mm)
- Small screwdriver
- Wrench for cable glands
- Wrench for wall mounting bracket (remote version only)
- Torque wrench for installing flowmeter in pipeline

3.5 Installation requirements

3.5.1 Vibration

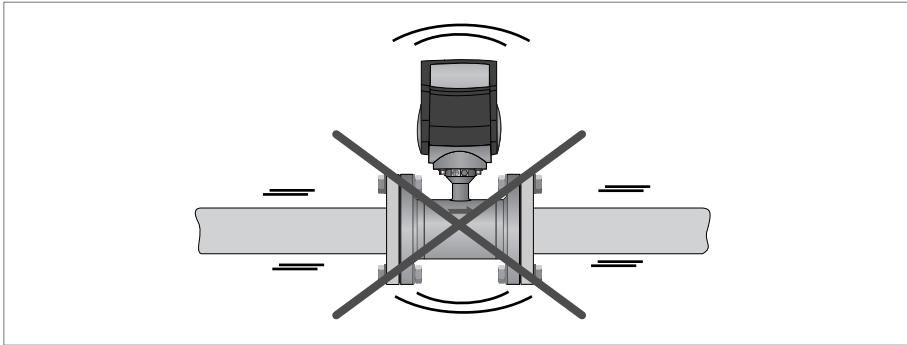

Figure 3-2: Vibration

3.5.2 Magnetic field

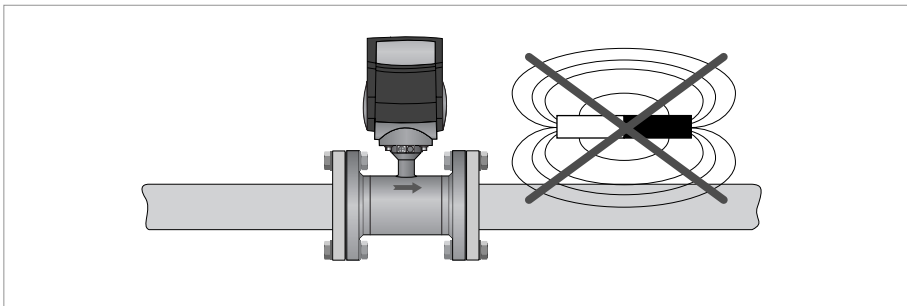

Figure 3-3: Magnetic field

3.5.3 Installation of converter



INFORMATION!

Only applicable for remote versions.



- Mount converter with mounting plate on wall or standpipe.
- Keep distance between sensor and signal converter as short as possible.
- Observe length of the delivered signal cable.

4.1 Safety instructions

**WARNING!**

Observe without fail the local occupational health and safety regulations. Any work done on the electrical components of the measuring device may only be carried out by properly trained specialists.

**INFORMATION!**

Look at the device nameplate to ensure that the device is delivered according to your order. Check for the correct supply voltage printed on the nameplate.

4.2 Grounding

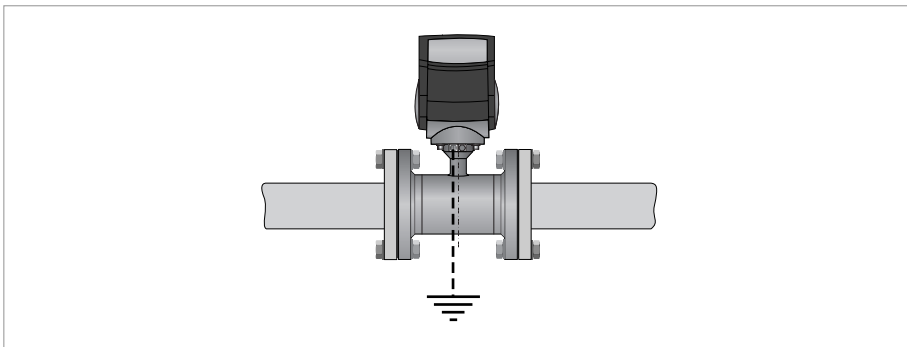

Figure 4-1: Grounding

4.3 Signal cable

**CAUTION!**

To ensure smooth functioning, always use the signal cables included in the delivery.

**INFORMATION!**

You only receive a signal cable if you ordered a remote version.

4.4 Connection of signal cable



INFORMATION!

The signal cable is only used with remote versions. The standard KROHNE WSC-cable includes both electrode and field current leads, the optional type A / B cable is only used for the electrodes. In that case, the field current cable is no part of the supply.

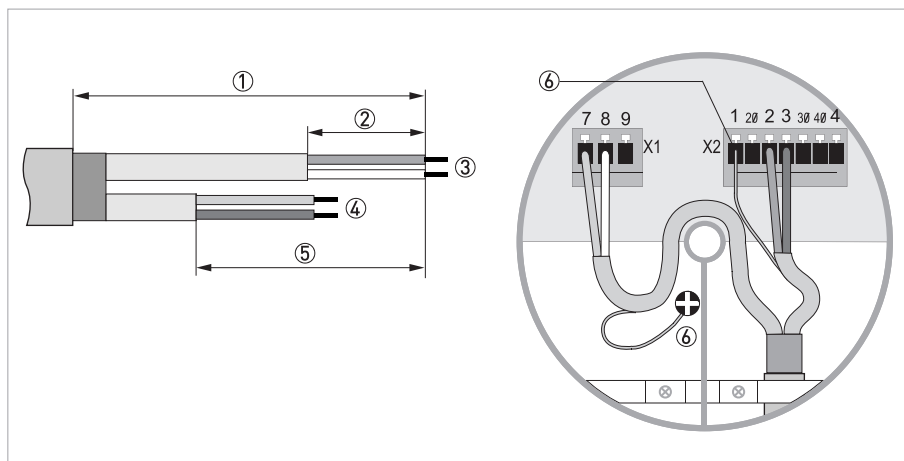

Figure 4-2: Cable connection at converter side, standard cable

- ① cable length: 13 cm / 5"
- ② cable length: 5 cm / 2"
- ③ brown + white cable, used for field current
- ④ purple and blue cable, used for electrode signals
- ⑤ cable length: 8 cm / 3"
- ⑥ Shield (terminal 1 of connector X2 + U-clamp)



- Prepare appropriate cable lengths (①...③)
- Connect the shield to the U-clamp, the brown cable to terminal 7 and the white to terminal 8.
- Connect the shield to terminal 1, the purple cable (white in case of type A or B cable) to terminal 2 and the blue (red in case of type A or B cable) to terminal 3.

4.5 Terminal assignment of converter

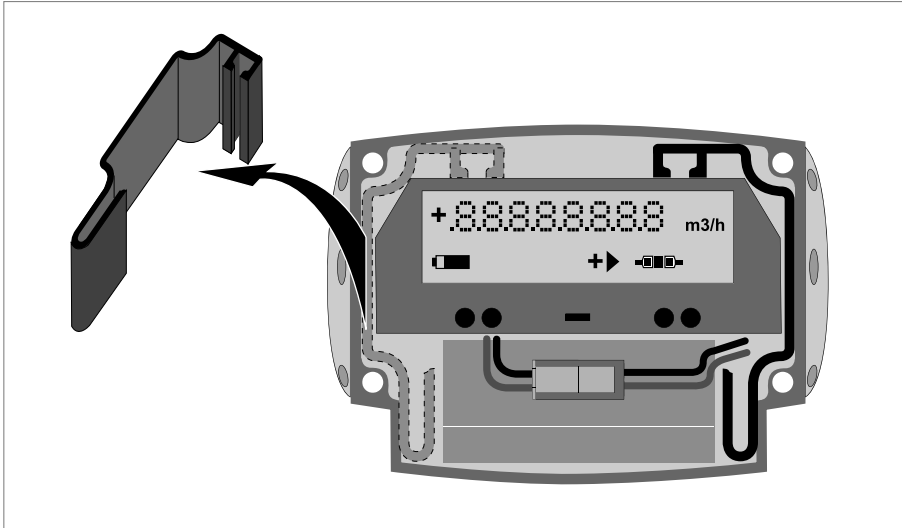

Figure 4-3: Removing side cap

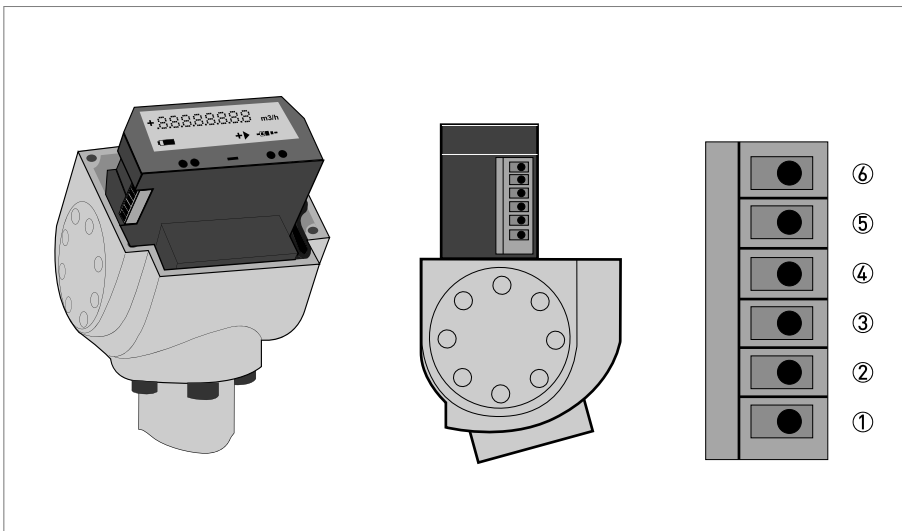

Figure 4-4: Terminal assignment

- ① Status output 1
- ② Status output 2
- ③ Not connected
- ④ Ground
- ⑤ Pulse output A
- ⑥ Pulse output B

Electrical values

- **Pulse output passive:**
 $f \leq 500 \text{ Hz}$; $I \leq 10 \text{ mA}$; $U: 2.7 \dots 24 \text{ VDC}$ ($P \leq 100 \text{ mW}$)
- **Status output passive:**
 $I \leq 10 \text{ mA}$; $U: 2.7 \dots 24 \text{ VDC}$ ($P \leq 100 \text{ mW}$)

5.1 Connection of battery



CAUTION!

Please connect battery before first use, see relevant chapter for your type of battery. Each converter is always delivered with a disconnected battery.

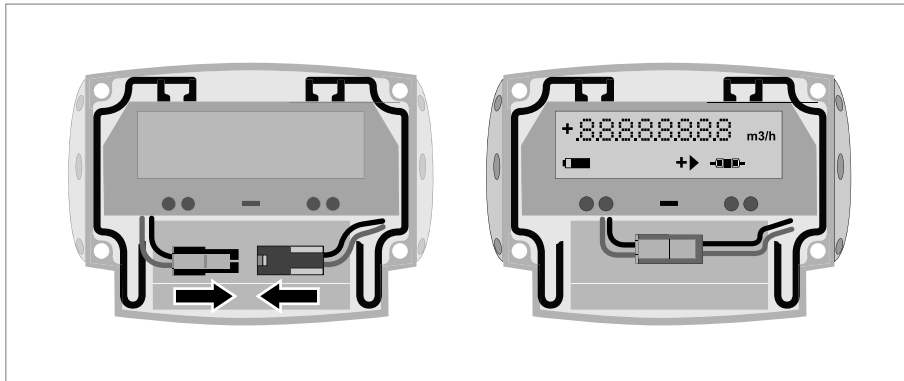

Figure 5-1: Connecting battery

5.1.1 Internal battery



- Remove the blue protection cap.
- Loosen the 4 Allen bolts (4 mm).
- Remove the cover.
- Fasten the battery connector to the internal connector in the converter.
- Check that the display lights up.
- Put the cover back.



WARNING!

Make sure that the battery cable is not jammed by the cover.



- Tighten the 4 Allen bolts.
- Put the blue protection cap back.



INFORMATION!

The instrument now operates with factory set parameters. For configuration of these settings, please refer to the handbook and/or the documentation of the converter.

5.1.2 External battery



- Remove the blue protection cap.
- Loosen the 4 Allen bolts (4 mm).
- Remove the cover.
- Remove one of the blind cable glands in the bottom of the converter housing.
- Remove the metal strip at the bottom of the housing (2 screws).
- Lead the cable of the external battery through the gland opening and mount the attached cable gland loosely.
- Pull the cable to the top of the electronics.
- Fasten the battery connector to the internal connector in the IFC 070 converter.

- Check that the display lights up.
- Refit the metal strip at the bottom of the housing.
- Tighten the cable gland.
- Put the cover back.

**WARNING!**

Make sure that the battery cable is not jammed by the cover.



- Tighten the 4 Allen bolts.
- Put the blue protection cap back.

**INFORMATION!**

The instrument now operates with factory set parameters.

For configuration of these settings, please refer to the handbook and/or the documentation of the converter.

6.1 Display and operating elements

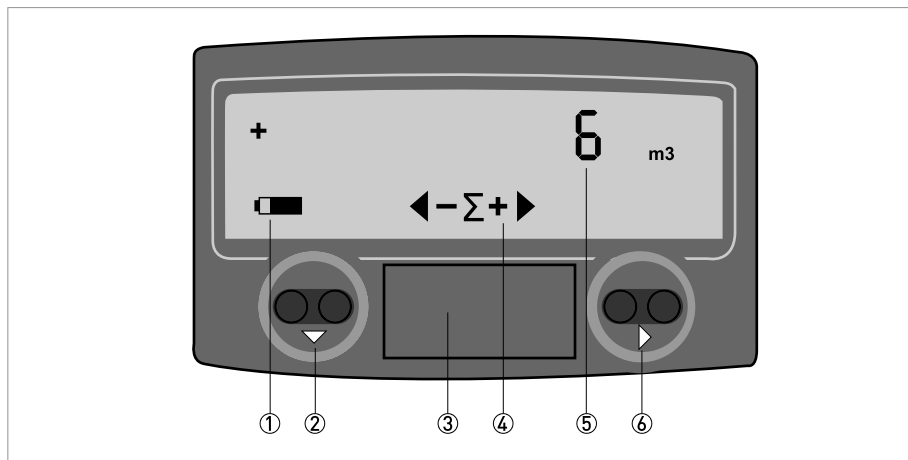

- ① battery status
- ② optical key ▽ to navigate through the menu and to scroll through the measuring pages
- ③ reset button (only accessible with removed cover)
- ④ flow direction
- ⑤ measured value and measuring unit
- ⑥ optical key ▷ to navigate through the menu

6.2 Menu of converter



- To enter the menu, hold the ▽ and ▷ key for 5 seconds.
- ➡ The display flashes.
- Press the ▷ key to enter the menu.
- ➡ You see the menu number at the left (12 at the beginning) and the value at the right side of the display.
- Scroll through the available positions with the ▽ key to the position you want to change.
- Press the ▷ key to enter the value.
- ➡ The value flashes.
- Use the ▷ and ▽ key to change the value.
- Hold the ▷ key for 3 seconds to confirm the new value.
- To leave the programming mode, hold the ▽ key for 3 seconds to store the new value(s). If you do not want to store the new values, do not touch any key for 60 seconds.

Other functions:

- software version: press ▷ key for 1 second
- display test: press ▷ key twice for 1 second

**CAUTION!**

Take care with changing menu number 13. If you set this to "1", the display locks. IF this happens:



- Remove the protection cap.
- Loosen the 4 Allen bolts (4 mm).
- Remove the cover.
- Press both keys simultaneously and press the reset button for 6 seconds as shown in the graph below. Use a small screwdriver for the reset button.
- Display starts with the menu, beginning with menu no. 12.
- Go to menu no. 13 and change 1 into 0.
- Hold the \triangleright key for 3 seconds to confirm the new value.
- Put the cover back.

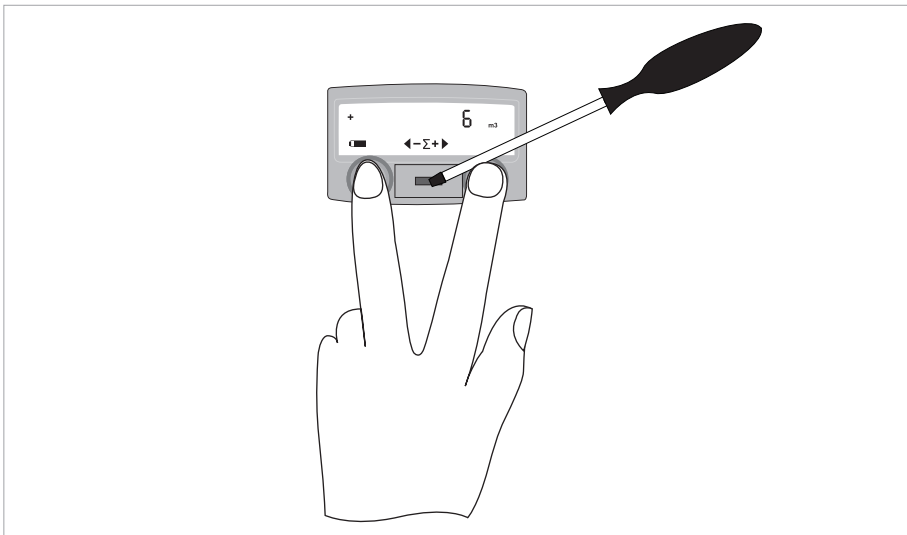

Figure 6-1: Entering the menu if menu no. 13 is set to 1 (fiscal metering active)

**WARNING!**

Make sure that the battery cable is not jammed by the cover.



- Tighten the 4 Allen bolts.
- Put the blue protection cap back.

Software version 4.0.4_				
Menu No.	Description	Display default	Selection list	Remarks
12	Measuring unit	0	0 = m ³ /h	Customer defined
			1 = USG/min	
			2 = l/s	
13	Access control	0	0 = Standard	Fiscal metering blocks menu, refer to figure above this table.
			1 = Fiscal metering	
20	Meter type	0	0 = WATERFLUX 3070	Select "0" in case of a square cross section, select "1" in case of a round cross section.
			1 = OPTIFLUX 2070	
21	Meter size	100	Defined at factory calibration	Choose from table, in chosen unit (menu no. 12).
22	Meter constant	01.000	Defined at factory calibration	Meter constant is shown on typeplate.
23	Zero offset calibration	0	Set to 1	In situ determination of zero point.
			Confirm with ">" for 3 seconds	After countdown meter switches to measuring mode.
				Menu no. 24 is automatically set to 1.
24	Zero selection	0	0 = factory calibration	Selection which zero point to use
			1 = measured	
25	Flow direction	0	0 = Forward	-
			1 = Reverse	
26	Measuring rate	15	1, 5, 10, 15, 20 seconds	Measurement interval in seconds
27	Low flow cut off	10	0, 5, 10 mm/s	Measurements below this value are neglected
28	Time constant flow reading	2	1 = fast,	Time constant of display
			2 = normal	
			3 = slow	
30	Self check	0	0 = off	Is automatically switched on at fiscal metering (menu no. 13 = 1)
			1 = on	
31	Empty pipe detection	0	0 = off	If switched on, display shows "- EP -". See graph below this table.
			1 = on	
32	Simulate outputs	0	0 = off	If set to on, display shows 0 and 1 alternately (independent of setting in menu no. 41/42). Set to "0" to stop the simulation.
			1 = on (1 pulse per second)	
41	Output A (pulse)	0	0 = off	Set pulse rate in menu no. 45
			1 = on	
42	Output B (pulse)	0	0 = off	Set pulse rate in menu no. 45
			1 = on	
43	Phase shift between pulse outputs	90	90 degrees offset	
			180 degrees offset	
			F-r (A - forward flow, B - reverse flow)	
44	Pulse width	1	1, 5, 10, 50, 100 ms	Choose from table
45	Pulse value	00.100	in m ³ /pulse or 100 USG/pulse	-

Software version 4.0.4_				
Menu No.	Description	Display default	Selection list	Remarks
51	Status output 1 Self checking	0	0 = off	Active at instrument failure, e.g. coil, electrode, battery. Can be reset by menu no. 72.
			1 = on	
52	Status output 1 Battery pre warning	0	0 = off	Active at low battery (10% left). Can be reset by menu no. 72.
			1 = on	
53	Status output 1 Battery final warning	0	0 = off	Active at very low battery (1% left). Can be reset by menu no. 72.
			1 = on	
54	Status output 1 Counter overrun	0	0 = off	Active if counter goes from 99999999 to 00000000. Can be reset by menu no. 72.
			1 = on	
55	Status output 2 Self checking	0	0 = off	Active at instrument failure. Can be reset by menu no. 72.
			1 = on	
56	Status output 2 Battery pre warning	0	0 = off	Active at low battery (10% left). Can be reset by menu no. 72.
			1 = on	
57	Status output 2 Battery final warning	0	0 = off	Active at very low battery (1% left). Can be reset by menu no. 72.
			1 = on	
58	Status output 2 Counter overrun	0	0 = off	Active if counter goes from 99999999 to 00000000. Can be reset by menu no. 72.
			1 = on	
59	Status outputs pulsating	1	0 = off	Pulse width determined by menu no. 44. Can be reset by menu no. 72.
			1 = on	
60	Show flow rate	0	0 = off	-
			1 = on	
61	Show counter forward	0	0 = off	-
			1 = on	
63	Show counter reverse	0	0 = off	-
			1 = on	
65	Show net counter	1	0 = off	-
			1 = on	
66	All counters reset	88888	Set to 00000	After reset display value is back to 88888
			Confirm with ">" for 3 seconds	
71	Counters run/stop	1	0 = stop	For service / maintenance purposes, pulse output also stops.
			1 = run	
72	All errors reset	0	Set to 1	After reset display value is back to 0
			Confirm with ">" for 3 seconds	
73	Battery type	2	0 = non (external power supply)	Wrong setting influences battery lifetime calculation.
			1 = single (19 Ah)	
			2 = dual (38 Ah)	
			3 = external (76 Ah)	
74	Battery capacity	19.000	Value in Ah	-

Software version 4.0.4_				
Menu No.	Description	Display default	Selection list	Remarks
75	Reset battery life time counter	0	Set to 1	After reset menu value is back to 0.
			Confirm with ">" for 3 seconds	
76	Load default settings	0	Set to 1	After reset menu value is back to 0, manual reprogramming necessary.
			Confirm with ">" for 3 seconds	
77	Fiscal metering verification reading	0	0 = off	Test modus, for verification at/by authority, display indicates P8888888, decimal separator position varies per diameter.
			1 = on	

Empty pipe detection

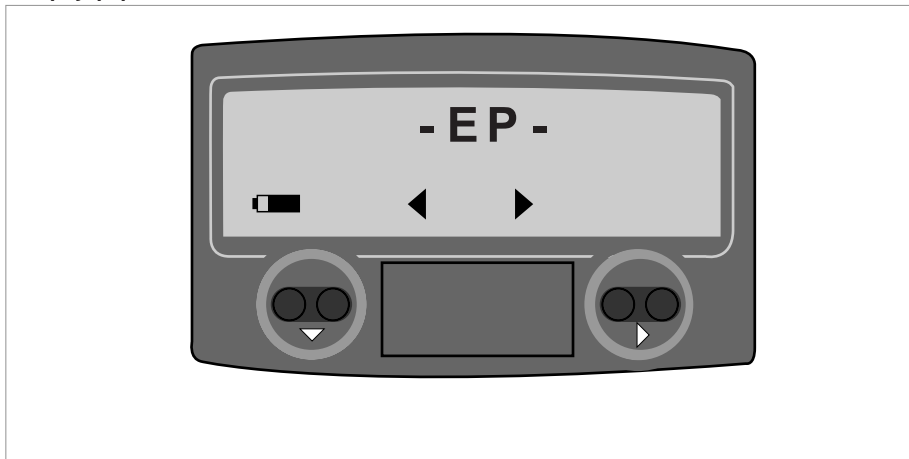

Figure 6-2: Display in Empty Pipe situation (if menu 31 is set to "1")

7.1 Replacement of battery

Different type of batteries with different capacities are available. They can be exchanged by other types if wanted.

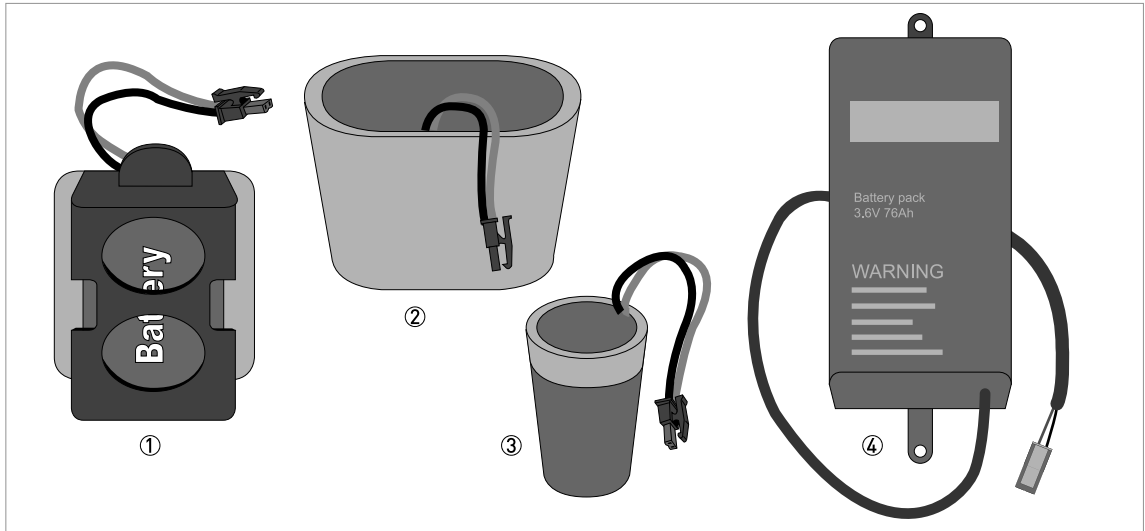

Figure 7-1: Batteries with cable and connector

- ① Internal battery in holder
- ② Internal dual pack battery
- ③ Internal single pack battery
- ④ External battery pack

7.1.1 Replacement of internal battery

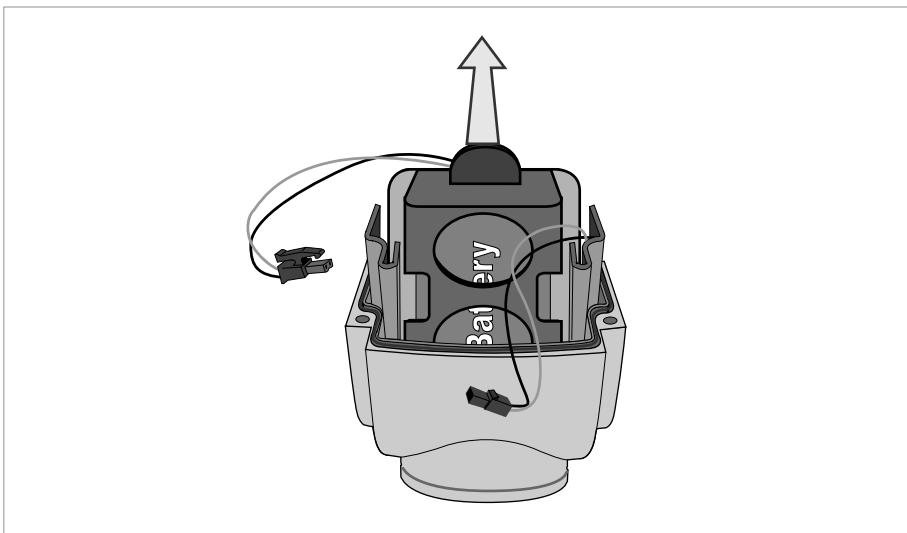

Figure 7-2: Removing battery



- Remove the protection cap.
- Loosen the 4 Allen bolts (4 mm).
- Remove the cover.
- Disconnect the connector of the battery.

- Remove the battery holder by pulling it upwards.
- Remove the battery from the holder.
- Insert the new battery in the holder.
- Replace the holder.
- Fasten the battery connector to the internal connector in the converter.
- Check that the display lights up.
- Replace the cover.

**WARNING!**

Make sure that the battery cable is not jammed by the cover.



- Tighten the 4 bolts.
- Enter the programming mode, hold the ▽ and ▷ key for 5 seconds.
- ➡ The display flashes.
- Press the ▷ key to enter the menu.
- Scroll through the available positions with the ▽ key to position 74 and check the battery capacity (important for battery life indication):
 - internal single pack battery: 19 Ah
 - internal dual pack battery: 38 Ah
 - External battery pack: 76 Ah
- Go to position 75 and enter "1" (reset battery counter).
- ➡ Battery capacity symbol at the display should be "full".
- Hold the ▽ key for 3 seconds to confirm the new value and go back to the measuring mode.
- Put the blue protection cap back.

7.1.2 Replacement of external battery

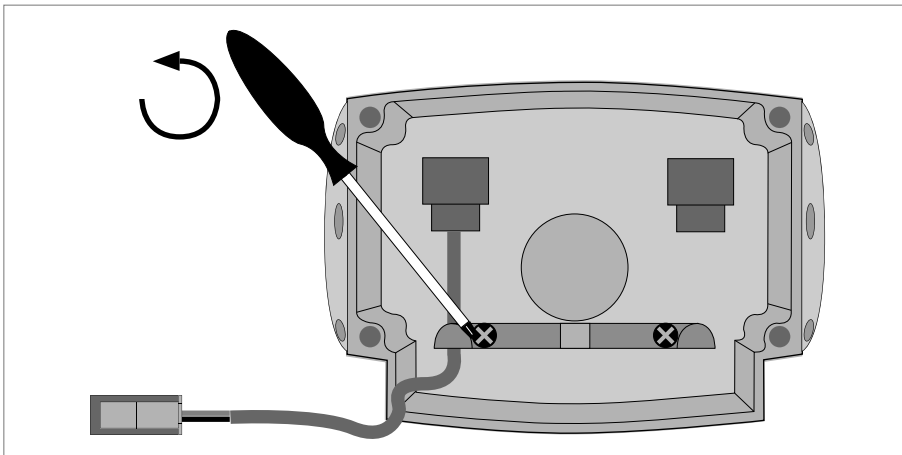

Figure 7-3: Removing metal strip



- Remove the blue protection cap.
- Loosen the 4 Allen bolts (4 mm).
- Remove the cover.
- Loosen the used cable gland in the bottom of the converter housing.
- Remove the metal strip at the bottom of the housing (2 screws).
- Disconnect the connector of the battery.
- Remove the cable of the old battery.

- Lead the cable of the new external battery through the gland opening and mount the attached cable gland loosely.
- Pull the cable to the top of the electronics.
- Fasten the battery connector to the internal connector in the IFC 070 converter.
- Check that the display lights up.
- Refit the metal strip at the bottom of the housing.
- Tighten the cable gland.
- Put the cover back.

**WARNING!**

Make sure that the battery cable is not jammed by the cover.



- Tighten the 4 bolts.
- Enter the programming mode, hold the ▽ and ▷ key for 5 seconds.
 - ➡ The display flashes.
- Press the ▷ key to enter the menu.
- Scroll through the available positions with the ▽ key to position 74 and check the battery capacity (important for battery life indication):
 - internal single pack battery: 19 Ah
 - internal dual pack battery: 38 Ah
 - External battery pack: 76 Ah
- Go to position 75 and enter "1" (reset battery counter).
 - ➡ Battery capacity symbol at the display should be "full".
- Hold the ▽ key for 3 seconds to confirm the new value and go back to the measuring mode.
- Put the blue protection cap back.

7.2 Spare parts availability

The manufacturer adheres to the basic principle that functionally adequate spare parts for each device or each important accessory part will be kept available for a period of 3 years after delivery of the last production run for the device.

This regulation only applies to spare parts which are under normal operating conditions subjects to wear and tear.

7.3 Availability of services

The manufacturer offers a range of services to support the customer after expiration of the warranty. These include repair, technical support and training.

**INFORMATION!**

For more precise information, please contact your local representative.

7.4 Returning the device to the manufacturer

7.4.1 General information

This device has been carefully manufactured and tested. If installed and operated in accordance with these operating instructions, it will rarely present any problems.

**CAUTION!**

Should you nevertheless need to return a device for inspection or repair, please pay strict attention to the following points:

- *Due to statutory regulations on environmental protection and safeguarding the health and safety of our personnel, manufacturer may only handle, test and repair returned devices that have been in contact with products without risk to personnel and environment.*
- *This means that the manufacturer can only service this device if it is accompanied by the following certificate (see next section) confirming that the device is safe to handle.*

**CAUTION!**

If the device has been operated with toxic, caustic, flammable or water-endangering products, you are kindly requested:

- *to check and ensure, if necessary by rinsing or neutralizing, that all cavities are free from such dangerous substances,*
- *to enclose a certificate with the device confirming that is safe to handle and stating the product used.*

7.4.2 Form (for copying) to accompany a returned device

Company:		Address:	
Department:		Name:	
Tel. no.:		Fax no.:	
Manufacturer's order no. or serial no.:			
The device has been operated with the following medium:			
This medium is:	water-hazardous		
	toxic		
	caustic		
	flammable		
	We checked that all cavities in the device are free from such substances.		
	We have flushed out and neutralized all cavities in the device.		
We hereby confirm that there is no risk to persons or the environment through any residual media contained in the device when it is returned.			
Date:		Signature:	
Stamp:			

7.5 Disposal

**CAUTION!**

Disposal must be carried out in accordance with legislation applicable in your country.

8.1 Measuring principle

An electrically conductive fluid flows inside an electrically insulating pipe through a magnetic field. This magnetic field is generated by a current, flowing through a pair of field coils. Inside of the fluid, a voltage U is generated:

$$U = v * k * B * D$$

in which:

v = mean flow velocity

k = factor correcting for geometry

B = magnetic field strength

D = inner diameter of flow meter

The signal voltage U is picked off by electrodes and is proportional to the mean flow velocity v and thus the flow rate q . The signal voltage is quite small (typically 1 mV at $v = 3$ m/s / 10 ft/s and field coil power of 1 W). Finally, a signal converter is used to amplify the signal voltage, filter it (separate from noise) and convert it into signals for totalising, recording and output processing.

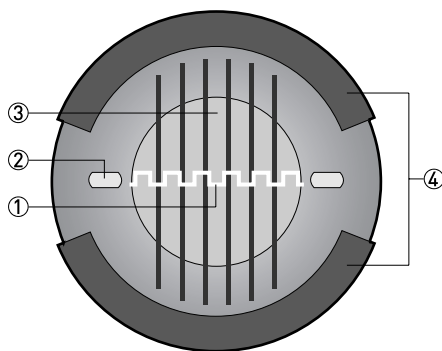

- ① Induced voltage (proportional to flow velocity)
- ② Electrodes
- ③ Magnetic field
- ④ Field coils

8.2 Technical data



INFORMATION!

- The following data is provided for general applications. If you require data that is more relevant to your specific application, please contact us or your local representative.
- Additional information (certificates, special tools, software,...) and complete product documentation can be downloaded free of charge from the website (Download Center).

Measuring system

Measuring principle	Faraday's law
Application range	Electrically conductive fluids
Measured value	
Primary measured value	Flow velocity
Secondary measured value	Volume flow

Design

Modular construction	The measurement system consists of a flow sensor and a signal converter. It is available as compact and as remote version. More information about the sensor can be found in the relevant documentation.
Compact version	With WATERFLUX 3000 sensor: WATERFLUX 3070 C
	With OPTIFLUX 2000 sensor: OPTIFLUX 2070 C
Remote version	With WATERFLUX 3000 sensor: WATERFLUX 3070 F
	With OPTIFLUX 2000 sensor: OPTIFLUX 2070 F
	Maximum cable length 25 m / 75 ft
User interface	
Display	8 digits LCD
	Display of positive and negative counter, sum counter, flow rate
	Status indication for battery, flow / counter direction, empty pipe
Units	Volume in m ³ , US Gallons
	Flow rate in m ³ /h, USGPM, l/s
Cable connections	Standard: 2x M20x1.5
	Optional: ½" NPT, PF½

Measuring accuracy

Reference conditions	Medium: water
	Temperature: 20°C / 68°F
	Inlet section: 5 DN
	Operating pressure: 1 bar / 14.5 psig
Maximum measuring error	±0.2% of measured value ±0.5 mm/s / 0.02 inch/s
	For detailed information on the measuring accuracy, see chapter "Measuring accuracy".
Repeatability	±0.1% (v > 0.5 m/s / 1.5 ft/s)

Operating conditions

Temperature	
Process temperature	-5...+70°C / 23...+158°F
Ambient temperature	-40...+65°C / -40...+149°F
Storage temperature	-50...+70°C / -58...+158°F
Chemical properties	
Physical condition	Liquids
Electrical conductivity	≥ 20 µS/cm
Recommended flow velocity	-9...9 m/s / -30...30 ft/s
Process conditions	Raw water, ground- and surface water
	Potable water
	Irrigation water

Installation conditions

Dimensions and weights	For detailed information see chapter "Dimensions and weights".
------------------------	--

Materials

Housing	Die-cast aluminium, polyurethane coated
Connection box (remote versions only)	Die-cast aluminium, polyurethane coated

Electrical connections

Power supply	
Battery	Standard
	1 Lithium battery (D-cell)
	Optional
	2 Lithium batteries (D-cell)
	External battery pack with 4 lithium batteries (D-cell, IP 68)
Typical lifetime	See graph at the end of this table.
Alarm	Pre-alarm at 10% of energy left
	Final alarm at 1% of energy left
Battery replacement	Possible without loss of totalizer data
In- and output	
Outputs	2 Passive pulse outputs for remote totalising: f ≤ 500 Hz; I ≤ 10 mA; U: 2.7...24 VDC (P ≤ 100 mW)
	2 Passive status outputs: I ≤ 10 mA; U: 2.7...24 VDC (P ≤ 100 mW)
Communication	Optional: external data logger / GSM module, SMS protocol to:
	SCADA system (at customer's site)
	OPC server (to be connected to customer's OPC client)
	PCWin (mini-SCADA can be supplied by us)

Approvals and certificates

CE	
	This device fulfills the statutory requirements of the EC directives. The manufacturer certifies successful testing of the product by applying the CE mark.
Electromagnetic compatibility	Directive: 2004/108/EC
	Harmonized standard: EN 61326-1 : 2006
Low voltage directive	Directive: 2006/95/EC
	Harmonized standard: EN 61010 : 2001
Hazardous areas	
Non-Ex	Standard
ATEX	Not available
Other approvals and standards	
Custody transfer	Standard: without verification
	MI-001 type examination certificate for DN50...200, pending for other diameters.
	OIML R-49 certificate of conformity for DN50...200, pending for other diameters.
	Conform EN 14154 / ISO 4064
Protection category acc. to IEC 529 / EN 60529	IP 66/67 (NEMA 4/4X/6)
Shock- and vibration resistance	IEC 68-2-3

Typical lifetime of batteries (at 25°C) for a DN80

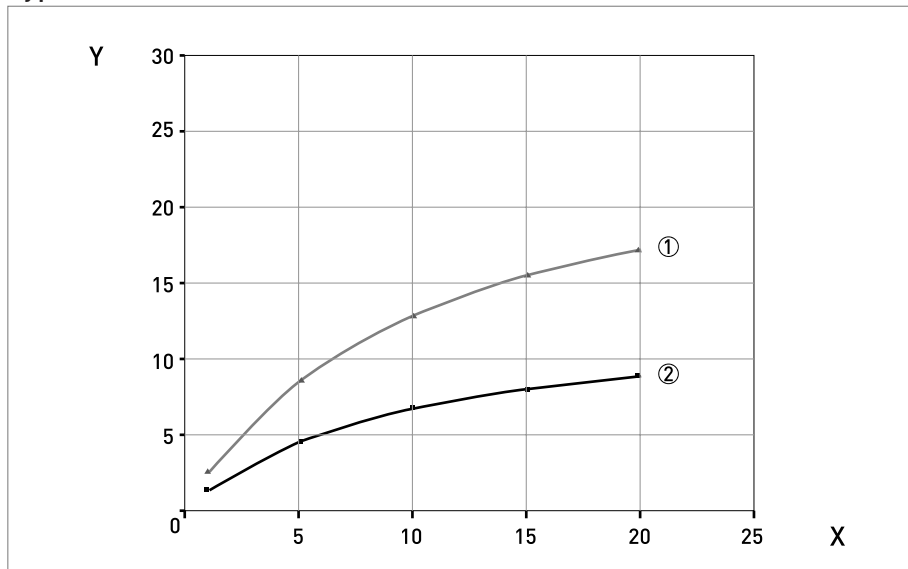

Figure 8-1: X = Sampling interval in seconds, Y = typical lifetime in years

- ① dual battery pack
- ② single battery

8.3 Measuring accuracy

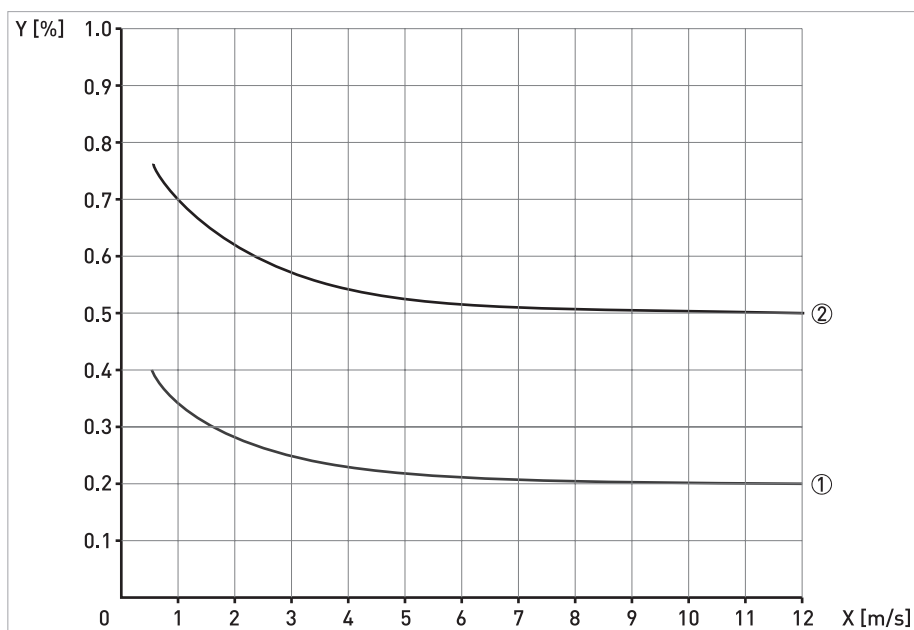

Figure 8-2: X = flow velocity [m/s], Y = deviation from the actual measured value [%]

- ① with WATERFLUX 3000 water meter
- ② with OPTIFLUX 2000 flow sensor

8.4 Dimensions and weights

Compact version	
	<p>a = 170 mm / 6.7"</p> <p>b = 132 mm / 5.3"</p> <p>c = 140 mm / 5.5"</p> <p>Weight of converter = 1.9 kg / 4.2 lbs</p> <p>Sizes of sensor can be found in the relevant datasheet.</p>
Remote version, signal converter	
	<p>b = 122 mm / 4.8"</p> <p>c = 235 mm / 9.3"</p> <p>H = 310 mm / 12.2"</p> <p>Weight of converter = 3.3 kg / 7.3 lbs</p>







KROHNE product overview

- Electromagnetic flowmeters
- Variable area flowmeters
- Ultrasonic flowmeters
- Mass flowmeters
- Vortex flowmeters
- Flow controllers
- Level meters
- Temperature meters
- Pressure meters
- Analysis products
- Measuring systems for the oil and gas industry
- Measuring systems for sea-going tankers

Head Office KROHNE Messtechnik GmbH
Ludwig-Krohne-Str. 5
D-47058 Duisburg (Germany)
Tel.: +49 (0)203 301 0
Fax: +49 (0)203 301 10389
info@krohne.de

The current list of all KROHNE contacts and addresses can be found at:
www.krohne.com

KROHNE