

Rosemount™ 2130 Level Switch

Vibrating Fork



- Designed for operation in process temperatures of -94 to 500 °F (-70 to 260 °C)
- Electronic self-checking and condition monitoring
- 'Heartbeat' LED gives status and instrument health information
- Increased safety, SIL2-certified to IEC 61508 as required by IEC 61511 and SIL3 capable
- Adjustable switching delay for turbulent or splashing applications
- "Fast drip" fork design gives quicker response time especially with viscous liquids
- General area, explosion-proof/flameproof, and intrinsically safe options

Introduction

Measurement principles

Using the principle of a tuning fork, a piezo-electric crystal oscillates the forks at their natural frequency. Changes to the oscillation frequency are continuously monitored by electronics as it varies depending on the liquid medium in which the forks are immersed. The denser the liquid, the lower the oscillation frequency.

When used as a low-level point alarm, the liquid medium in the vessel (tank) or pipe drains down past the fork, causing a change of oscillation frequency that is detected by the electronics and switches the output state i.e. wet-to-dry.

When the level switch is used as a high-level point alarm, the liquid rises in the vessel (tank) or pipe making contact with the fork and causing the output state to switch i.e. dry-to-wet.

Key features and benefits

- Virtually unaffected by turbulence, foam, vibration, solids content, coating products, or liquid properties.
- The mid-range temperature version of the Rosemount 2130 operates in process temperatures of -40 to 356 °F (-40 to 180 °C).
- The high temperature version of the Rosemount 2130 operates in process temperatures of -94 to 500 °F (-70 to 260 °C). It has a stainless steel thermal tube to move the electronics away from the process.
- Electronic self-checking and condition monitoring. The 'heartbeat' LED on the electronics cassette gives status and health information on the Rosemount 2130.
- Adjustable switching delay prevents false switching in turbulent or splashing applications.
- 'Fast drip' fork design gives quicker response time, especially with viscous liquids.
- Rapid wet-to-dry time for highly responsive switching.
- Fork shape is optimized for hand polishing to meet hygienic requirements.
- No moving parts or crevices for virtually no maintenance.
- There is a variety of plug-in electronics options, each having an adjustable mode and switching delay.

Contents

Introduction.....	2
Ordering information.....	7
Specifications.....	15
Product certifications.....	22
Dimensional drawings.....	23

Superior performance

- Functionality is virtually unaffected by turbulence, foam, vibration, coating, or liquid properties.
- The 'fast drip' design allows the liquid to be quickly drawn away from the fork tip, making the level switch quicker and more responsive in high density or viscous liquid applications.

Figure 1: 'Fast Drip' Forks



Fit and forget

- Once installed, the Rosemount 2130 is ready to go. It needs no calibration and requires minimum installation.
- The 'heartbeat' LED gives an instant visual indication that the unit is operational.
- Functional testing of the instrument and system is easy with a magnetic test point.
- You can install, and forget it.

Built-in diagnostics

- Built-in diagnostics continuously check electronic and mechanical health.
- Fork conditions detected including internal and external damage, coated or blocked, and extreme corrosion.
- Ideal for critical alarm duties.

Extended high and low temperature performance

The high temperature version of the Rosemount 2130 enables standardization of Emerson's vibrating fork switches and detectors across a wide range of process environments, and is ideally suited for harsh conditions where high reliability is essential.

Quick release kit

The Quick Release kit makes inspection, proof-testing, and servicing easier than ever.

Figure 2: Quick Release Kit

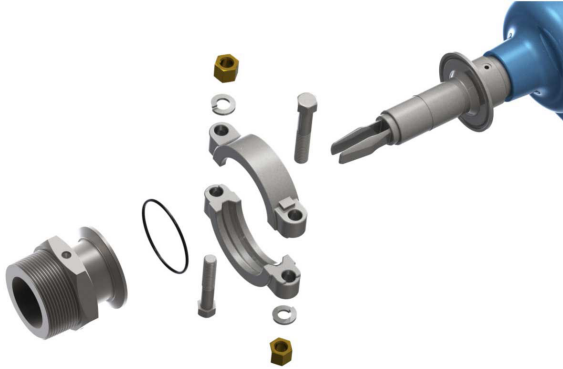

Related information

[Spare parts and accessories](#)

Access information when you need it with asset tags

Newly shipped devices include a unique QR code asset tag that enables you to access serialized information directly from the device. With this capability, you can:

- Access device drawings, diagrams, technical documentation, and troubleshooting information in your MyEmerson account
- Improve mean time to repair and maintain efficiency
- Ensure confidence that you have located the correct device
- Eliminate the time-consuming process of locating and transcribing nameplates to view asset information

Application examples

Overfill prevention

Spillage caused by overfilling can be hazardous to people and the environment, resulting in lost product and potentially high clean-up costs. The Rosemount 2130 is an overfill prevention product from Emerson that can be used as one of multiple layers of protection. It has been third party assessed and certified to IEC 61508.



High and low level point alarm

Maximum and minimum level detection in tanks containing different types of liquids are ideal applications. It is common practice to have an independent high level alarm switch as a backup to an installed level device in case of primary failure.

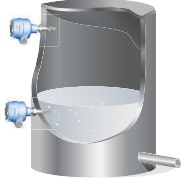

Pump control or limit detection

Batch processing tanks often contain stirrers and agitators to ensure mixing and product 'fluidity'. The Rosemount 2130 has a user-selectable time delay, from 0.3 to 30 seconds, that virtually eliminates the risk of false switching from splashing.

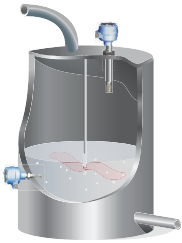

Pump protection or empty pipe detection

With the fork projecting only 2 in. (50 mm) (dependent on connection type), the Rosemount 2130 can be installed in small diameter pipes. Short forks mean minimum intrusion on the wet side and allow for simple, low cost installation at any angle into pipes or tanks. By selecting the option of direct load switching or relay electronics, the Rosemount 2130 is ideal for reliable pump control and can be used to protect against pumps running dry.



High-temperature applications

The 2130****E version is designed for high temperatures and is suitable for continuous operation within the process temperature range of -94 to 500 °F (-70 to 260 °C).

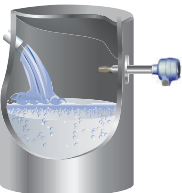

Wireless applications

The advent of wireless communications allows process plant managers to save up to 90% on installation cost compared with wired technologies. More data can be collected at central locations than has ever been possible before. The Rosemount 2130 can be used with a Rosemount 702 Wireless Discrete Transmitter to enable these benefits for your applications.

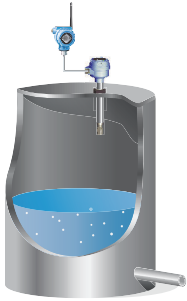

Hygienic applications

With the highly polished forks option providing a surface finish (Ra) better than 0.4 μm , the Rosemount 2130 meets the most stringent hygienic requirements used in food and beverage, and pharmaceutical applications. The Rosemount 2130 is robust enough to easily withstand CIP (Clean-In-Place) and SIP (Steam-In-Place) cleaning routines.

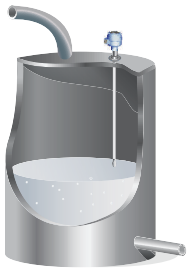

Ordering information

Online product configurator

Many products are configurable online using our product configurator.

Select the **Configure** button or visit [Emerson.com/global](https://emerson.com/global) to start. With this tool's built-in logic and continuous validation, you can configure your products more quickly and accurately.

Specifications and options

The purchaser of the equipment must specify and select the product materials, options, or components.

Related information

[Specifications](#)

[Material selection](#)

Model codes

Model codes contain the details related to each product. Exact model codes will vary; an example of a typical model code is shown in [Figure 3](#).

Figure 3: Model Code Example

2130 LA 2 ES 9 NN BA 0000 1 NA	Q8
1	2

1. Required model components (choices available on most)
2. Additional options (variety of features and functions that may be added to products)

Optimizing lead time

The starred offerings (★) represent the most common options and are recommended for the fastest delivery times. The non-starred offerings are subject to additional delivery lead time.

Rosemount 2130 Level Switch ordering information



The Rosemount 2130 Level Switch is developed for challenging applications, tough operating conditions and safety critical environments. Its robust construction and built-in powerful diagnostics will allow you to focus on the essential part - your plant. It is a plug-and-play device, which means that it is easy to install and does not require any advanced configuration or calibration. It is also virtually unaffected by process conditions, which makes its measurements extremely reliable. The Rosemount 2130 is SIL 2 certified for safety instrumented systems. It will make sure that you stay safe from overflow, while at the same time optimizing your tank usage.

[CONFIGURE >](#)
[VIEW PRODUCT >](#)

Required model components

Model

Code	Description	
2130	Enhanced Vibrating Fork Liquid Level Switch	★

Output

Code	Description	
L	Direct Load Switching (Mains 2-wire) 20 to 264 Vac, 50/60 Hz, 20 to 60 Vdc, Self-checking	★
P	PNP/PLC Low Voltage (3-wire) 20 to 60 Vdc, Self-checking	★
D	Relay DPCO (Double Pole Changeover), 20 to 264 Vac, 50/60 Hz, 20 to 60 Vdc, Self-checking (Fault and Alarm Relays version is available by selecting D and adding "R2264" to end of model number)	★
N	NAMUR, 8 Vdc, Self-checking	★
M	8/16 mA, Self-checking	★

Related information

[Electrical connections](#)

Housing material

Code	Description	
A	Aluminum	★
S	Stainless Steel	★

Conduit entry / cable threads

Code	Description	Available certifications	
9	¾-in. NPT	NA, E5, E6, G5, G6, I1, I2, I3, I4, I5, I6, I7, IW	★
2	M20	NA, E1, E2, E3, E4, E7, EW, I1, I2, I3, I4, I5, I6, I7, IW	★

Operating temperature

Code	Description	
M	Mid-Range: -40 °F (-40 °C) to 356 °F (180 °C)	★
E	High: -94 °F (-70 °C) to 500 °F (260 °C)	★

Materials of construction: process connection/fork

Flanges are dual certified 316 and 316L Stainless Steel (1.4401 and 1.4404).

Code	Description	
S	316/316L Stainless Steel (1.4401/1.4404)	★
F ⁽¹⁾⁽²⁾⁽³⁾	ECTFE Copolymer, Coated 316/316L Stainless Steel (1.4401/1.4404)	★
H ⁽⁴⁾	Alloy C (UNS N10002), Alloy C-276 (UNS N10276)	★

(1) Only available for wetted parts.

(2) Option is not available for hand polished wet side as standard.

(3) Only available for a flanged Rosemount 2130; the operating temperature code M must be selected (mid-range) and the process temperature must be below 302 °F (150 °C).

(4) Only available for BSPT and NPT threaded process connection codes 9-NN-B, 9-NN-N, 1-NN-B, and 1-NN-N as standard, other upon request.

Process connection size

Code	Description	
9	¾-in. / 19 mm	★
1	1-in. / 25 mm (DN25)	★
2	2-in. / 50 mm (DN50)	★
5	1½-in. / 40 mm (DN40)	★
3	3-in. / 80 mm (DN80)	★
4	4-in. / 100 mm (DN100)	★
7	2½-in. / 65 mm (DN65)	★

Process connection rating

Other process connections available upon request.

Code	Description	
AA	ASME B16.5 Class 150 flange	★
AB	ASME B16.5 Class 300 flange	★
AC	ASME B16.5 Class 600 flange	★
DA	EN1092-1 PN 10/16 flange	★
DB	EN1092-1 PN 25/40 flange	★
DC	EN1092-1 PN 63 flange	★
DD	EN1092-1 PN 100 flange	★
NN	For use with non-flange process connection type	★

Process connection type

Other process connections available upon request.

Code	Description	
R	Raised Face (RF) Flange	★
B	BSPT (R) Thread	★
G	BSPP (G) Thread	★
N	NPT Thread	★
P	BSPP (G) O-ring	★
C	Tri-Clover Clamp	★

Fork length

Code	Description	Process connection	
A	Standard length 1.7 in. (44 mm)	All except flanged options	★
H	Standard length flange 4.0 in. (102 mm)	All flanged options	★
E	Extended, customer specified length in tenths of inches	All except connection 1-NN-P	★
M	Extended, customer specified length in millimeters	All except connection 1-NN-P	★

Related information

[Customer specified fork length](#)

Specific extended fork length

Code	Description	
0000	Factory default length (only if fork length A or H is selected)	★
xxxx ⁽¹⁾	Specific customer specified length in tenths of inches or millimeters (xxx.x inches or xxxx mm)	★

(1) Examples: Code E1181 is 118.1 inches. Code M3000 is 3000 millimeters.

Related information

[Customer specified fork length](#)

Surface finish

Code	Description	Process connections	
1	Standard surface finish	All	★
2 ⁽¹⁾⁽²⁾	Hand polished (Ra < 0.4 µm)	P or C	★

(1) Not available with Material of Construction Process / Fork option code H.

(2) Hand-polished for hygienic connections to better than 0.4 µm Ra such that there are no pits, folds, crevices or cracks discernible to the naked eye (i.e. no features larger than 75 micrometers based on resolving 1/60 degree at a distance of 250 mm).

Product certificates

Code	Description	Available output	Conduit entry/ cable threads	
NA	No hazardous locations certifications (safe area use only)	All	All	★
G5 ⁽¹⁾	USA Ordinary Locations (unclassified, safe area)	All	¾-in. NPT only	★
G6 ⁽²⁾⁽³⁾	Canada Ordinary Locations (unclassified, safe area)	All	¾-in. NPT only	★

Code	Description	Available output	Conduit entry/ cable threads	
E1	ATEX Flameproof	All	M20 only	★
E2	Brazil Flameproof	All except Fault Relays	M20 only	★
E3	China Explosion-proof	All	M20 only	★
E4	Japan Flameproof	All	M20 only	★
E5 ⁽¹⁾	USA Explosion-proof	All	¾-in. NPT only	★
E6 ⁽²⁾⁽³⁾	Canada Explosion-proof	All	¾-in. NPT only	★
E7	IECEX Explosion-proof	All	M20 only	★
EW	India Flameproof	All	M20 only	★
I1	ATEX Intrinsic Safety	NAMUR or 8/16 mA	All	★
I2	Brazil Intrinsic Safety	NAMUR or 8/16 mA	All	★
I3	China Intrinsic Safety	NAMUR or 8/16 mA	All	★
I4	Japan Intrinsic Safety	NAMUR or 8/16 mA	All	★
I5	USA Intrinsic Safety	NAMUR or 8/16 mA	All	★
I6 ⁽³⁾	Canada Intrinsic Safety	NAMUR or 8/16 mA	All	★
I7	IECEX Intrinsic Safety	NAMUR or 8/16 mA	All	★
IW	India Intrinsic Safety	NAMUR or 8/16 mA	All	★

(1) E5 includes G5 requirements. G5 is for use in unclassified, safe area locations only.

(2) E6 includes G6 requirements. G6 is for use in unclassified, safe area locations only.

(3) The requirements of CRN are met when a Rosemount 2130 CSA-approved vibrating fork level switch (with Product Certifications code G6, E6, or I6) is configured with stainless steel wetted parts and either NPT threaded or ASME B16.5 2-in. to 4-in. flanged process connections.

Related information

[Product certifications](#)

Additional options

Calibration data certification

Code	Description	
Q4	Certificate of functional test	★

Material traceability certification

Only available for wetted parts.

Option is not available for hand polished wet side as standard.

Code	Description	
Q8	Material traceability certification per EN 10204 3.1	★

Material certification

Only available for wetted parts.

Option is not available for hand polished wet side as standard.

Code	Description	
Q15	NACE® MR0175 / ISO 15156	★
Q25	NACE MR0103	★

Safety certification

Code	Description	
QS	Prior-use certificate of FMEDA Data	★
QT	Safety certified to IEC61508	★

Dye penetration test certificate

Code	Description	
Q73	Certificate of liquid penetrant inspection	★

Positive material identification certificate

Code	Description	
Q76	Positive material identification certificate of conformance	★

Special procedures

This option is limited to units with extended lengths up to 59.1 in. (1500 mm). Option is not available for ECTFE coating.

Code	Description	
P1	Hydrostatic testing with certificate	★

Low liquid density range

Code	Description	
LD	Low density liquids – minimum density is 31.2 lb/ft ³ (500 kg/m ³)	★

Extended product warranty

Code	Description	
WR3	3-year limited warranty	★
WR5	5-year limited warranty	★

Overfill approval option

The Rosemount 2130 has been TÜV-tested and approved for overfill protection according to the German DIBt/WHG regulations. If required, add "R2259" to the end of the model number.

Spare parts and accessories

Seal

Part number	Description
02100-1000-0001	Seal for 1-in. BSPP (G1A) process connection. Material: Non-asbestos BS7531 grade X carbon fiber with rubber binder
02100-1040-0001	Seal for ¾-in. BSPP (G3/4A) process connection. Material: Non-asbestos BS7531 grade X carbon fiber with rubber binder

Adaptor boss

Part number	Description
02100-1010-0001	Adaptor boss, 1-in. BSPP to 1½-in. (38 mm) Tri Clamp Materials: 316 stainless steel fitting, FPM/FKM O-ring

Tri Clamp kit

Part number	Description
02100-1020-0001	2-in. (51 mm) Tri Clamp kit (vessel fitting, clamp ring and seal) Materials: 316 stainless steel, NBR Nitrile

Test magnet

Part number	Description
02100-1030-0001	Telescopic test magnet

Replacement cassettes

Intrinsically Safe (IS) approved cassettes can only be replaced with the same type of IS cassette. Non-IS cassette types can be interchanged with other non-IS cassettes, but the new label must be fitted and the original part number transferred to the new label.

Part number	Description
02130-7000-0001	Replacement cassette: Direct load switching (Red)
02130-7000-0002	Replacement cassette: PNP/PLC low voltage (Yellow)
02130-7000-0003	Replacement cassette: NAMUR current switching (Light Blue)
02130-7000-0004	Replacement cassette: DPCO Relay (Dark Green)
02130-7000-0005	Replacement cassette: Direct load switching, low density range selection (Red)
02130-7000-0006	Replacement cassette: PNP/PLC low voltage, low density range selection (Yellow)
02130-7000-0007	Replacement cassette: NAMUR current switching, low density range selection (Light Blue)
02130-7000-0008	Replacement cassette: DPCO Relay, low density range selection (Dark Green)
02130-7000-0009	Replacement cassette: 8/16 mA (Dark Blue)
02130-7000-0010	Replacement cassette: 8/16 mA, low density range selection (Dark Blue)
02130-7000-0011	Replacement cassette: Fault and Alarm Relays (2 x SPCO) (Light Green)
02130-7000-0012	Same as replacement cassette 02130-7000-0011 but with low density range selection

Related information

- [Output](#)
- [Product certificates](#)

Quick release kit

The quick release kit is a set of accessories requiring a Rosemount 2130 with the 2-in. Tri Clamp option and an existing 2-in. NPT process connection on the vessel.

Part number	Description
02100-1060-0001	Quick release kit (contains 2-in. Tri Clamp, seal, and quick release device for 2-in. NPT process connection)

Related information

- [Release Kit Quick Start Guide](#)

Specifications

General

Measuring technology

Vibrating fork

Applications

Point level detection in liquid process mediums, including coating liquids, aerated liquids, and slurries. Suitable for horizontal and vertical installation.

Physical specifications

Material selection

Emerson provides a variety of Rosemount products with various product options and configurations, including materials of construction that can be expected to perform well in a wide range of applications. The Rosemount product information presented is intended as a guide for the purchaser to make an appropriate selection for the application. It is the purchaser's sole responsibility to make a careful analysis of all process parameters (such as all chemical components, temperature, pressure, flow rate, abrasives, contaminants, etc.), when specifying product, materials, options, and components for the particular application. Emerson is not in a position to evaluate or guarantee the compatibility of the process fluid or other process parameters with the product, options, configuration, or materials of construction selected.

Housing/Enclosure

Table 1: Housing / Enclosure Specifications

Housing code	A-2	A-9	S-2	S-9
Housing material	Aluminum Alloy ASTM B85 A360.0		316C12 Stainless Steel	
Rotational	No	No	No	No
Paint	Polyurethane		Not applicable	
LED window	None		None	
Conduit entry	M20	¾-in. NPT	M20	¾-in. NPT
Ingress protection	IP66/67 to EN60529, NEMA® 4X		IP66/67 to EN60529, NEMA 4X	

Process wetted connections

Connections

Threaded, Tri Clamp, and flanged process connection options.

Materials

- 316/316L stainless steel (1.4401/1.4404 dual-certified)
- Alloy C (UNS N10002) and Alloy C-276 (UNS N10276)
Available for flanged, and selected threaded process connections (¾-in. and 1-in. BSPT (R), and ¾-in. and 1-in. NPT).
- ECTFE co-polymer coated 316/316L Stainless Steel (1.4401/1.4404 dual certified)
Available only for flanged process connections.
- Gasket material for ¾-in. and 1-in. BSPP (G) is non-asbestos BS7531 Grade X carbon fiber with rubber binder.
Gaskets are not supplied with flanged process connections.

Customer specified fork length

Table 2: Extended Fork Lengths

Process connection	Minimum	Maximum ⁽¹⁾
¾-in. threaded	3.8 in. (95 mm)	157.5 in. (4000 mm)
1-in. threaded	3.7 in. (94 mm)	157.5 in. (4000 mm)
Flanged	3.5 in. (89 mm)	157.5 in. (4000 mm)
Tri Clamp	4.1 in. (105 mm)	157.5 in. (4000 mm)

(1) *The maximum extended length is 157.5 in. (4000 mm), except for ECTFE co-polymer coating and polished process connection options which have a maximum length of 59.1 in. (1500 mm) and 39.4 in. (1000 mm) respectively.*

Related information

[Dimensional drawings](#)

Performance specifications

Hysteresis (water)

0.1 in. (2.5 mm)

Switching point (water)

0.5 in. (13 mm) from fork tip if mounted vertically.

0.5 in. (13 mm) from the fork edge if mounted horizontally.

The switching point varies with different liquid densities.

Liquid density requirements

Minimum standard density is 37.5 lb/ft³ (600 kg/m³).

Minimum density is 31.2 lb/ft³ (500 kg/m³ when ordered with the Low Density Range option.

Liquid viscosity range

Up to 10000 cP (centiPoise) when operating in the Normal mode.

Up to 1000 cP (centiPoise) when operating in Self-check mode.

Solids content and coating

The maximum recommended diameter of solid particles in the liquid is 0.2 in. (5 mm) when used in Normal mode only. Avoid bridging of forks (fork-to-fork).

Operating modes

Table 3: Operating Modes

Fault conditions detected	Normal mode	Self-check mode
PCB control circuit corruption	Yes	Yes
External damage to fork	No	Yes
Internal damage to sensor	No	Yes
Excessive corrosion	No	Yes
Over-temperature	No	Yes

Electrical specifications

Protections

Table 4: Electrical Protections

Protection	Availability on Cassettes
Polarity insensitive	Direct Load and Relay electronics
Over-current protection	Direct Load and PNP/PLC electronics
Short-circuit protection	Direct Load and PNP/PLC electronics
Load-missing protection	Direct Load and PNP/PLC electronics
Surge protection (to IEC61326)	All electronics

Terminal connection (wire diameter)

Minimum 26 AWG, maximum 14 AWG (0.13 to 2.5 mm²). Note national regulations.

Conduit plugs/cable glands

Conduit entries for explosion-proof areas are shipped with one Exd plug (loose in bag) and two dust caps fitted. Use suitably rated cable glands. Unused conduit entries must be sealed with a suitably rated blanking plug. Local codes and regulations must be complied with.

Electrical connections

Note

The external DPST switch that is shown in the wiring diagrams is an optional local disconnect (customer supplied).

Figure 4: Direct Load Switching (2-wire) Cassette (Red Label) – Code L

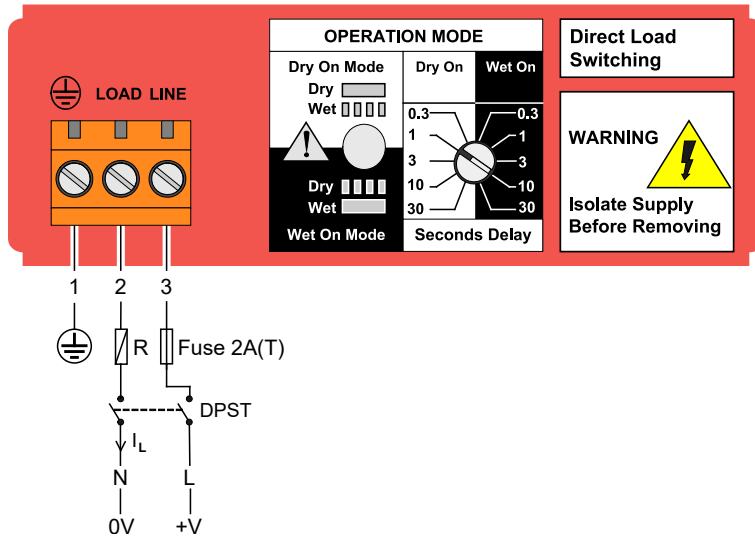

R = External load (must be fitted)

N = Neutral

L = Live

Figure 5: PNP/PLC (3-wire) Cassette (Yellow Label) – Code P

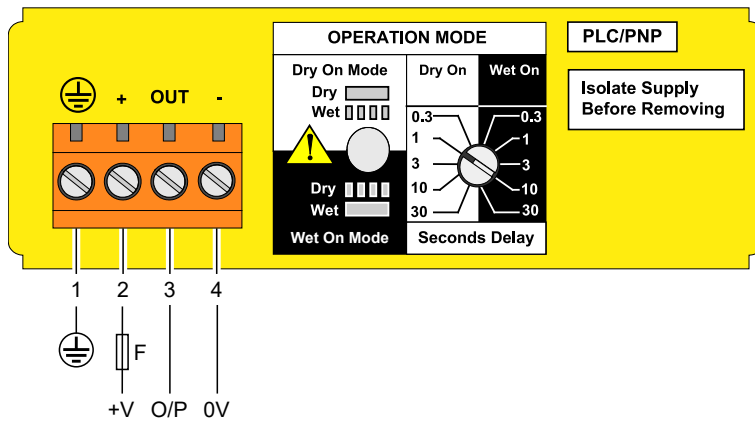

F = Fuse 2A(T)

Figure 6: Relay DPCO Cassette, Standard Version (Green Label) – Code D

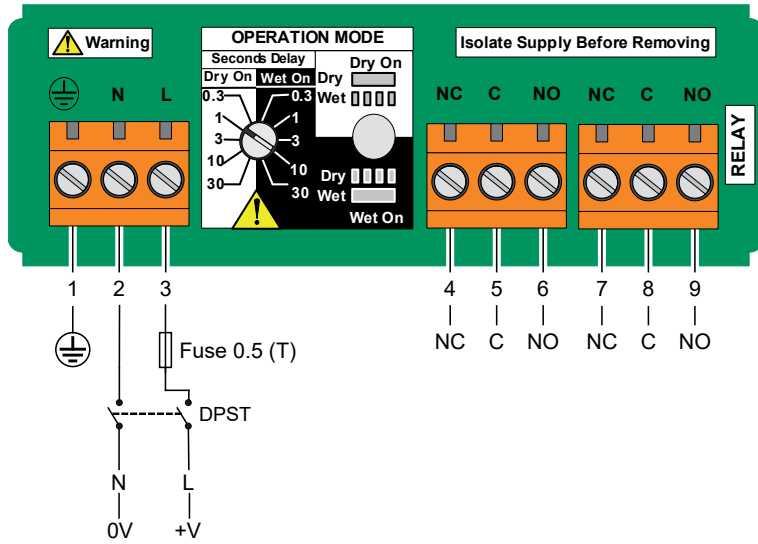

Figure 7: Fault and Alarm Relay Outputs Cassette (Light Green Label) – Code D with Option R2264

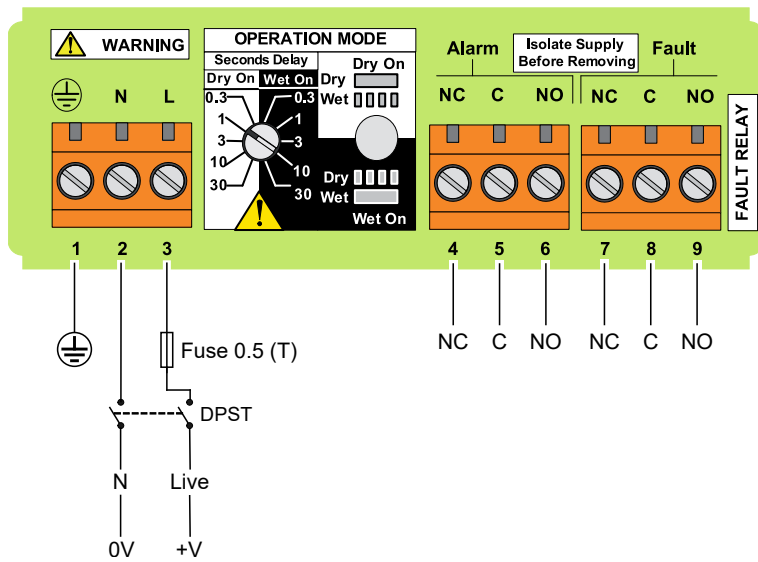
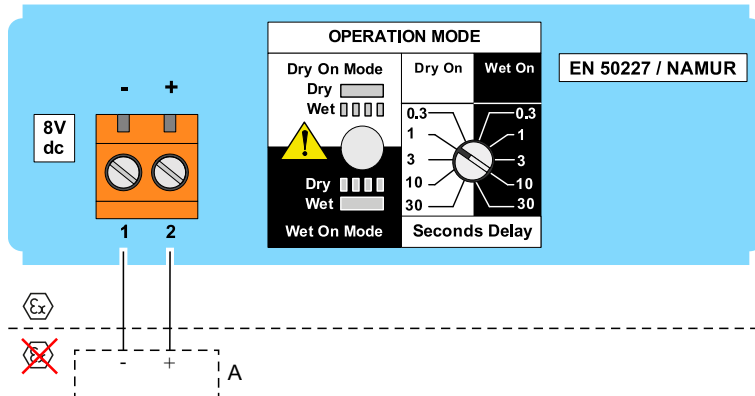
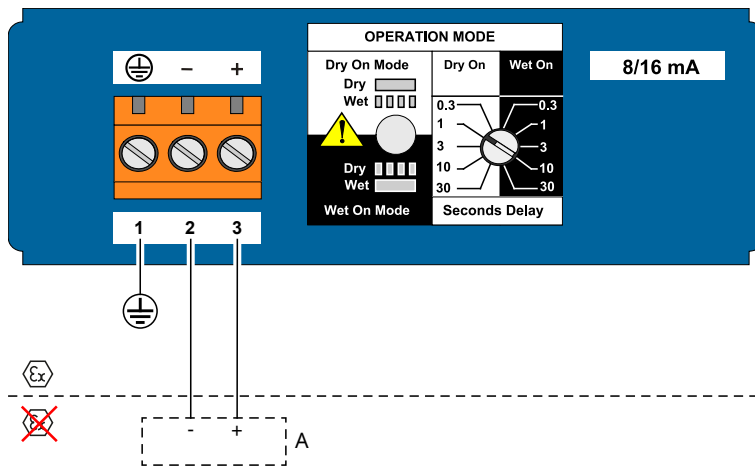

Figure 8: NAMUR Cassette (Light Blue Label) – Code N



A. A certified intrinsically safe isolating amplifier to IEC 60947-5-6

Figure 9: 8/16 mA Cassette (Dark Blue Label) – Code M



A. A certified intrinsically safe isolating amplifier to IEC 60947-5-6

Functional specifications

Switching delay

User-selectable 0.3, 1, 3, 10, 30 seconds delay for dry-to-wet and wet-to-dry switching.

Switching mode

User selectable switching mode (Dry=on or Wet=on).

Magnetic test point

A magnetic test point is located on the side of the housing, allowing a functional test of the Rosemount 2130 and a system connected to it. Holding a magnet to the test point causes the output to change state.

Heartbeat LED

Each electronics cassette of the level switch has a 'heartbeat' LED indicating its operation status. The LED flashes when the level switch output is 'off' and is constantly lit when 'on'.

The LED gives a constant indication that the level switch is functioning correctly (different flash rates are used to indicate a product malfunction) and gives a local indication of the process state.

Environmental specifications

Maximum operating altitude

6562 ft. (2000 m)

Maximum operating pressures

Figure 10: Process Pressure

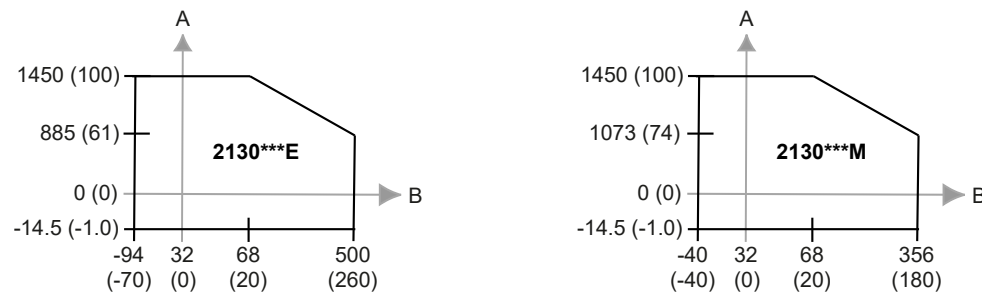

- A. Process pressure, psig (barg)
- B. Process temperature, °F (°C)

The final rating depends on the type of process connection.

Threaded connection

See [Figure 10](#).

Tri Clamp connection

435 psig (30 barg)

Flanged connection

The maximum operating pressure is the lower of the process pressure (see [Figure 10](#)) and flange pressure rating (see [Table 5](#)).

Table 5: Maximum Flange Pressure Rating

Standard	Class/Rating	Stainless steel flanges
ASME B16.5	Class 150	275 psig ⁽¹⁾
ASME B16.5	Class 300	720 psig ⁽¹⁾
ASME B16.5	Class 600	1440 psig ⁽¹⁾
EN1092-1	PN 10/16	16 barg ⁽²⁾
EN1092-1	PN 25/40	40 barg ⁽²⁾
EN1092-1	PN 63	63 barg ⁽²⁾
EN1092-1	PN 100	100 barg ⁽²⁾

(1) At 100 °F (38 °C), the pressure rating decreases with an increasing process temperature.
 (2) At 122 °F (50 °C), the pressure rating decreases with an increasing process temperature.

Maximum and minimum operating temperatures

See [Figure 11](#) for the maximum and minimum operating temperatures.

The ambient temperature for a 8/16 mA cassette is limited to 158 °F (70 °C) in dust applications.

Figure 11: Operating Temperature

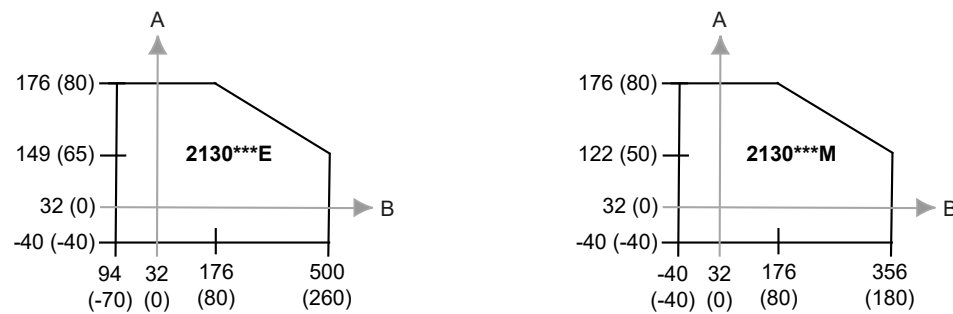

A. Ambient Temperature, °F (°C)
 B. Process Temperature, °F (°C)

Product certifications

See the Rosemount 2130 [Product Certifications](#) document for detailed information on the existing approvals and certifications.

Dimensional drawings

See the Rosemount 2130 [web page](#) for all hygienic dimensional drawings.

Figure 12: 3/4- and 1-in. Threaded Mounting (Standard Length)

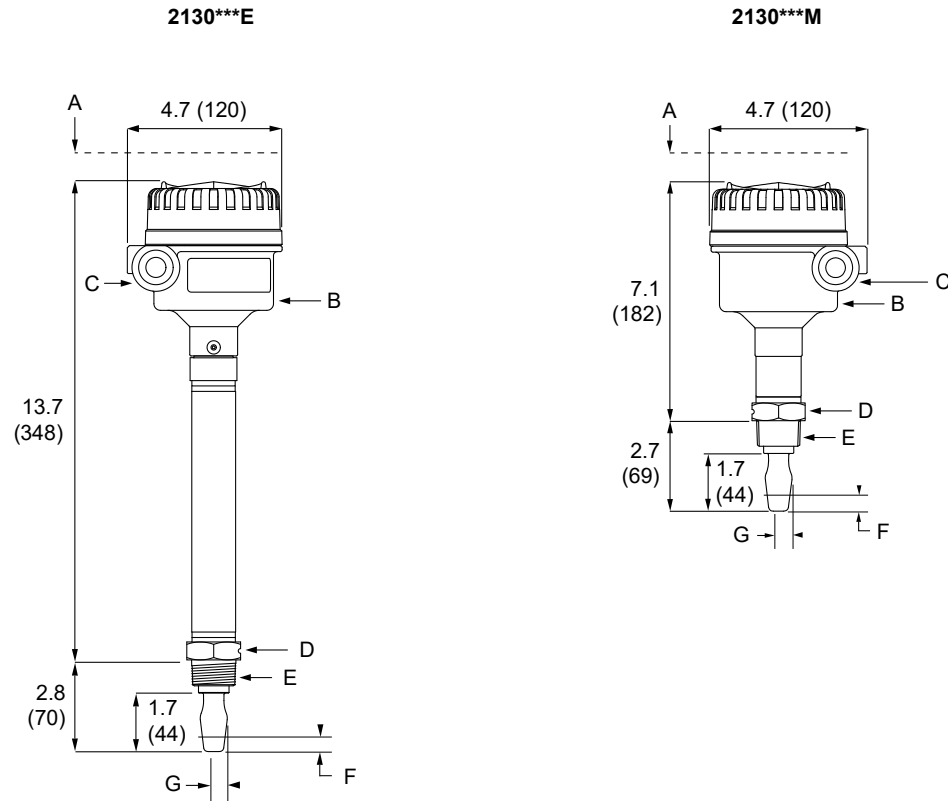

- A. Allow 1.2 (30) clearance to remove cover
- B. Aluminum or stainless steel housing
- C. Cable entry M20 x 1.5 or 3/4-in. NPT
- D. 1.6 (40) A/F hexagon
- E. 3/4- or 1-in. thread
- F. 0.5 (13) switchpoint (when mounted vertically)
- G. 0.5 (13) switchpoint (when mounted horizontally)

Dimensions are in inches (millimeters).

Figure 13: 3/4- and 1-in. Threaded Mounting (Extended Length)

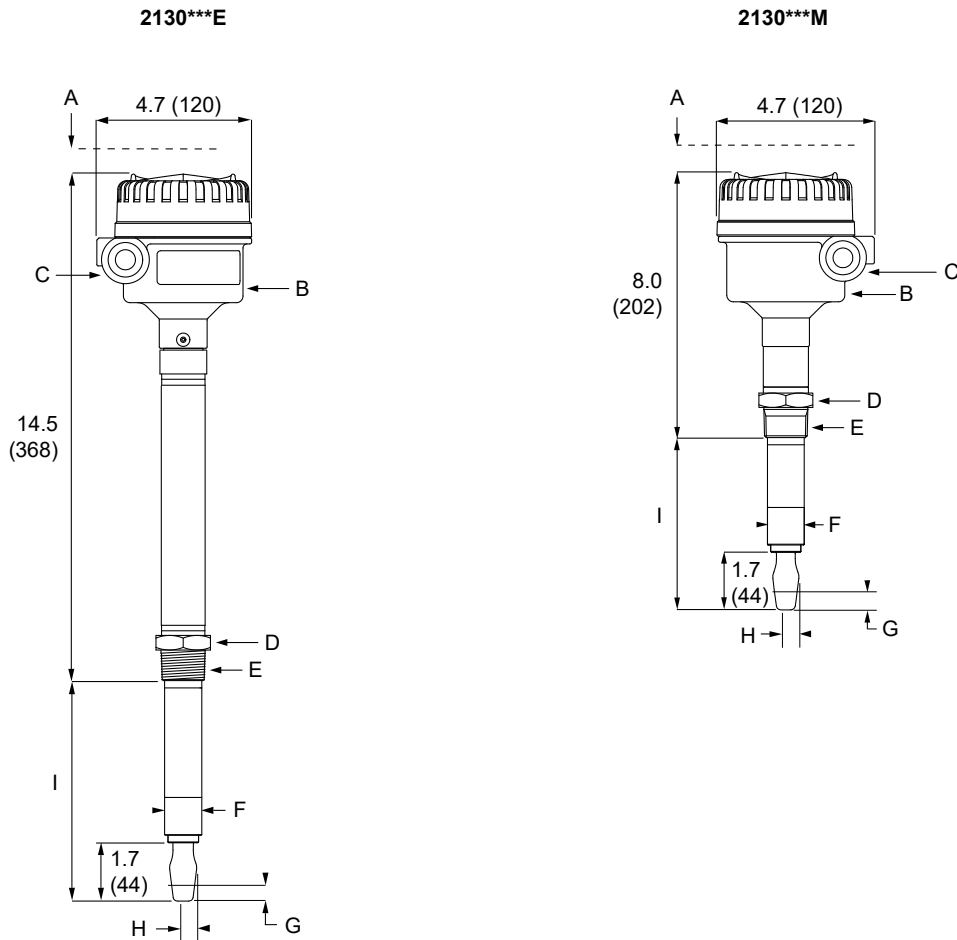

- A. Allow 1.2 (30) clearance to remove cover
- B. Aluminum or stainless steel housing
- C. Cable entry M20 x 1.5 or 3/4-in. NPT
- D. 1.6 (40) A/F hexagon
- E. 3/4- or 1-in. thread
- F. Ø1.1 (28) for 1-in. thread; Ø0.9 (23) for 3/4-in. thread
- G. 0.5 (13) switchpoint (when mounted vertically)
- H. 0.5 (13) switchpoint (when mounted horizontally)
- I. Customer specified fork length (see [Table 2](#))

Dimensions are in inches (millimeters).

Figure 14: Flange Mounting (Standard Length)

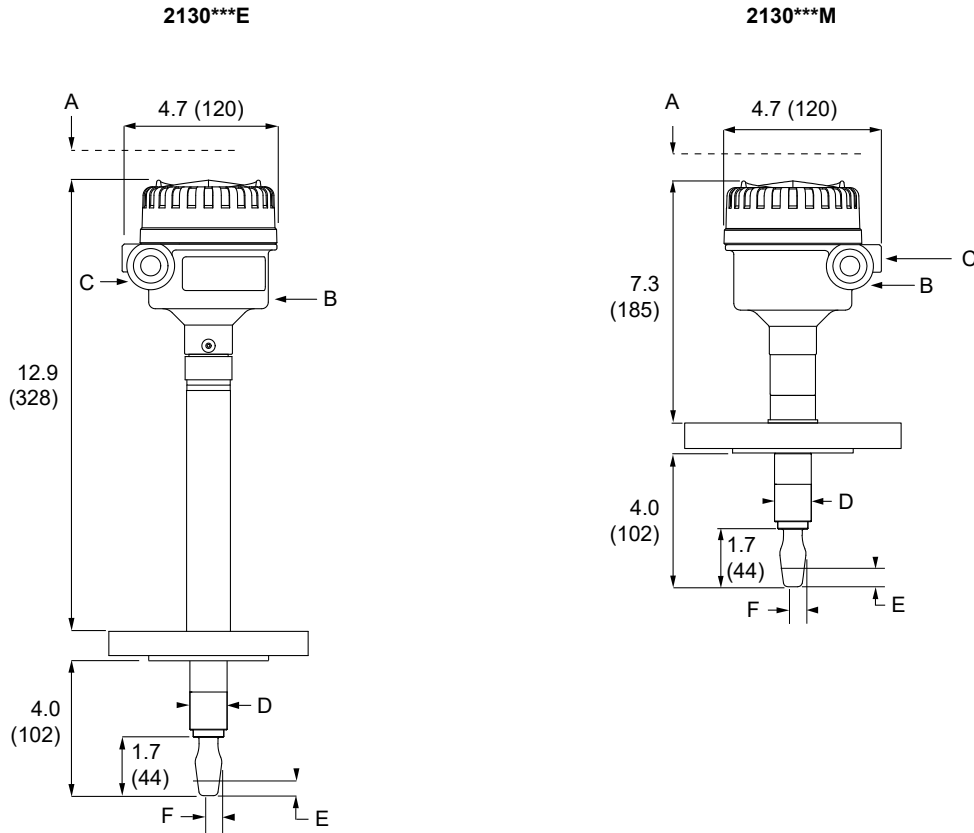

- A. Allow 1.2 (30) clearance to remove cover
- B. Aluminum or stainless steel housing
- C. Cable entry M20 x 1.5 or 3/4-in. NPT
- D. Ø1.1 (28) for 1½ -in. or larger flange; Ø0.9 (23) for up to 1-in. flange; Ø0.95 (24) for 1-in. coated flange
- E. 0.5 (13) switchpoint (when mounted vertically)
- F. 0.5 (13) switchpoint (when mounted horizontally)

Dimensions are in inches (millimeters).

Figure 15: Flange Mounting (Extended Length)

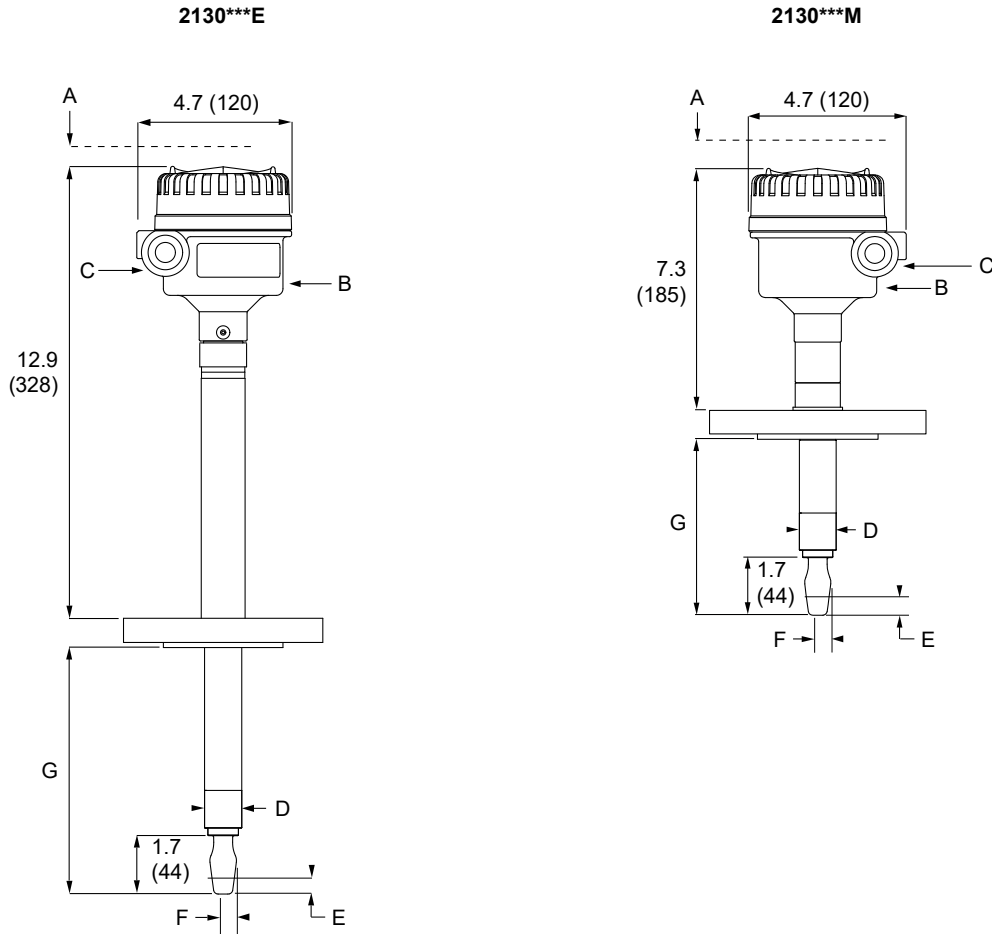

- A. Allow 1.2 (30) clearance to remove cover
- B. Aluminum or stainless steel housing
- C. Cable entry M20 x 1.5 or 3/4-in. NPT
- D. Ø1.1 (28) for 1½ -in. or larger flange; Ø0.9 (23) for up to 1-in. flange; Ø0.95 (24) for 1-in. coated flange
- E. 0.5 (13) switchpoint (when mounted vertically)
- F. 0.5 (13) switchpoint (when mounted horizontally)
- G. Customer specified fork length (see [Table 2](#))

Dimensions are in inches (millimeters).

For more information: [Emerson.com/global](https://emerson.com/global)

©2024 Emerson. All rights reserved.

Emerson Terms and Conditions of Sale are available upon request. The Emerson logo is a trademark and service mark of Emerson Electric Co. Rosemount is a mark of one of the Emerson family of companies. All other marks are the property of their respective owners.