

Band Heaters

Special Mica Barrel and Nozzle

For over 80 years, Watlow has been solving complex and unique application problems with standard mica barrel and nozzle heaters. Watlow is continuously improving design and application knowledge through engineering expertise and experience with numerous OEM and end-user applications.

This has resulted in the development of many specialty variations in construction resulting in the best heat solutions. This catalog contains a sampling of what can be done. Please contact a local Watlow sales engineer for custom applications.

Performance Capabilities

- Sheath temperatures to 480°C (900°F)
- Watt densities to 55 W/in² (8.5 W/cm²)

Features and Benefits

UL® component recognition

- Available for applications up to 480°C (900°F)

Patented clamping strap

- Assures efficient heat transfer

Low mass design

- Allows fast heat-up and quick response

Design variations

- Provides user convenience and heater protection

Applications

- Extruders
- Blown film dies
- Injection molding machines
- Other cylinder heating applications

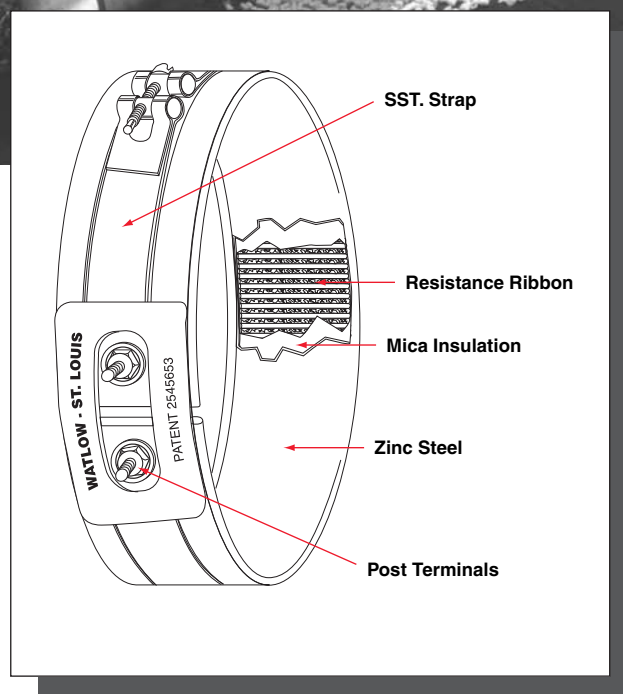

UL® is a registered trademark of Underwriter's Laboratories, Inc.

Band Heaters

Special Mica Barrel and Nozzle

Applications and Technical Data

Operating Factors

Use lowest watt density per the graph below. A close match of the heat supplied to the actual requirements will reduce temperature over-shoot, reduce cycling and increase the life of any band heater used.

Calculate the **safe maximum wattage** for the heater using:

Heated Area x Maximum Watt Density

Calculate the **heated area** of the band heater by subtracting the no-heat area from the total area in contact with the cylinder (3.14 x I.D. x width). Subtract the no-heat area at the terminals (from table) and any additional no-heat area caused by holes, slots or oversize gaps.

Determine the maximum watt density of the heater from the *Maximum Allowable Watt Density* graph. The curves are based on narrow heaters mounted on a smooth, steel cylinder. Apply the necessary correction factors:

- For heaters 2¼ inches (57 mm) to five inches wide (127 mm), multiply watt density by 0.8.
- For high expansion cylinders (aluminum or brass), reduce the watt density by 3 W/in² (0.46 W/cm²).
- For heaters 2¼ inches to five inches wide installed on a high expansion cylinder, reduce watt density by a total of 3 W/in² (0.46 W/cm²) only.
- For regular cylinder surfaces other than smooth, machined finish, reduce watt density by 3 W/in² (0.46 W/cm²).
- For heaters that will be insulated or enclosed, contact Watlow for specific watt densities.

No-Heat Area for Special Mica Band (Post Terminals)

Heater Type	Heater Size		No-Heat Area at Terminals in. (mm)
	Diameter in. (mm)	Width in. (mm)	
One Piece	Less than 2 (50.8)	Up to 6 (152.4)	1 (25.4) x width
		Up to 3 (76.2)	1½ (38.1) x width
	2 (50.8) or more	More than 3 (76.2)	1 (25.4) x width
Two Piece	3 (76.2) or more	Up to 3 (76.2)	3 (76.2) x width
		More than 3 (76.2)	2 (50.8) x width

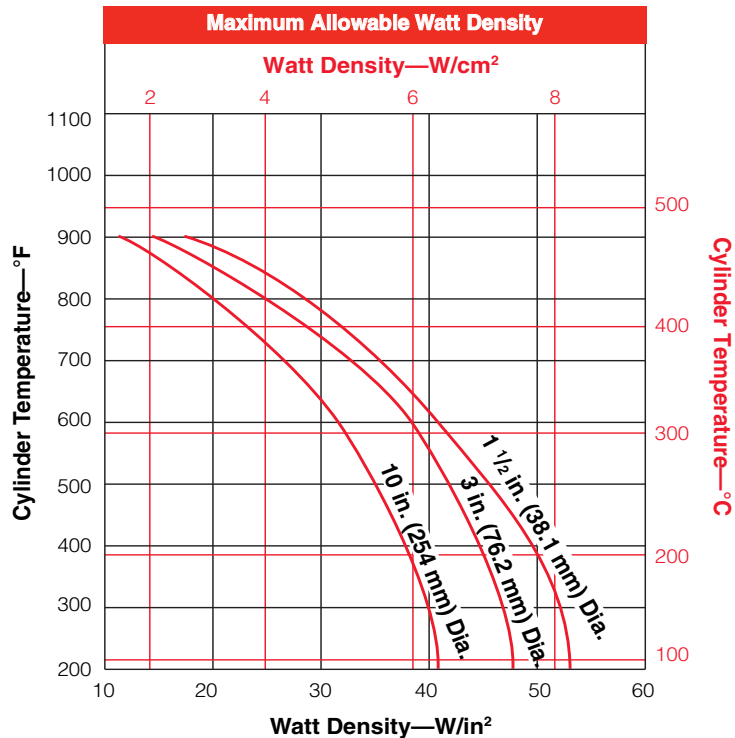

Band Heaters

Special Mica Barrel and Nozzle

Physical Limitations of Variations

Check the table to be certain the variations and lead arrangements being ordered are available on the heater size required. If you need to exceed any limitations, please contact a Watlow representative.

Physical Limitations of Variations

Heater Type	Diameter		Width	
	Min. in. (mm)	Max. in. (mm)	Min. in. (mm)	Max. in. (mm)
1 pc.	1 $\frac{1}{6}$ (33.3)	22 (559)	$\frac{5}{8}$ (15.8)	15 (381)
2 pc.	3 (76.2)	44 (1117)	$\frac{5}{8}$ (15.8)	15 (381)
Expandable:				
Narrow	1 $\frac{1}{4}$ (44.4)	— —	1 (25.4)	3 (76.2)
Wide	1 $\frac{3}{4}$ (44.4)	— —	2 (50.8)	6 (152.4)
O.D. heater				
1 pc.	3 (76.2)	22 (559)	1 (25.4)	6 (76.2)
2 pc.	3 (76.2)	44 (1117)	1 (25.4)	6 (76.2)
Type K leads	$\frac{3}{4}$ (19.05)	— —	1 (25.4)	15 (381)
Type L leads	$\frac{3}{4}$ (19.05)	— —	$\frac{5}{8}$ (15.8)	15 (381)
Type E leads	1 $\frac{1}{2}$ (38.1)	22 (559)	$\frac{5}{8}$ (15.8)	15 (381)
Type F leads	1 $\frac{1}{2}$ (38.1)	22 (559)	$\frac{5}{8}$ (15.8)	15 (381)
Type H leads	1 $\frac{1}{2}$ (38.1)	22 (559)	$\frac{5}{8}$ (15.8)	15 (381)
Type B leads	1 $\frac{1}{2}$ (38.1)	22 (559)	$\frac{3}{4}$ (19.05)	15 (381)
Post terminals	1 $\frac{1}{6}$ (33.3)	— —	1 (25.4)	15 (381)
Type A leads	$\frac{3}{4}$ (19)	— —	$\frac{5}{8}$ (15.8)	15 (381)
Type C leads	1 $\frac{1}{6}$ (33.3)	— —	1 (25.4)	15 (381)
Terminal box	3 $\frac{1}{2}$ (88.9)	— —	1 $\frac{1}{2}$ (34.9)	15 (381)
Plug w/bracket	3 (76.2)	— —	3 $\frac{1}{2}$ (88.9)	15 (381)
3-phase	— —	— —	3 (76.2)	15 (381)
European plug				
1 pc. vertical	1 $\frac{1}{6}$ (33.3)	22 (559)	1 (25.4)	15 (381)
1 pc. horizontal	3 (76.2)	22 (559)	2 (50.8)	15 (381)
2 pc. vertical	3 (76.2)	44 (1117)	1 (25.4)	15 (381)
2 pc. horizontal	3 (76.2)	44 (1117)	2 (50.8)	15 (381)
HV Wedge-Lok	1 (25.4)	3 (76.2)	1 (25.4)	6 (76.2)
Clamping tabs	2 (50.8)	— —	1 (25.4)	15 (381)
Welded barrel nuts				
1 pc.	2 (50.8)	22 (559)	1 (25.4)	15 (381)
2 pc.	4 (101.6)	44 (1117)	1 (25.4)	15 (381)

Note: Some combinations of maximum and minimums cannot occur on the same heater.

Standard gap is $\frac{1}{4}$ inch (6.35 mm)

Variations

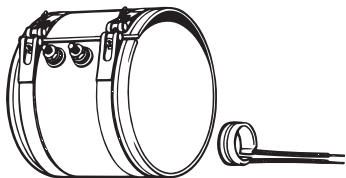

Different Widths

The 1 $\frac{1}{2}$ inch (38 mm) wide heater is the most efficient due to maximum clamping action. Heaters are available in widths from $\frac{5}{8}$ inch

(16 mm) to 15 inches (381 mm). Multiple clamping straps are provided for heaters more than three inches (76 mm) wide.

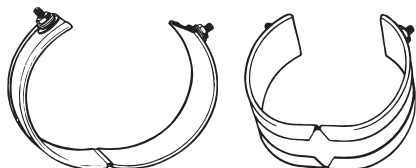

Expandable Heaters

Heaters three inches (76 mm) wide or less are constructed with a notched sheath. Heaters wider than three inches are constructed with an expansion seam. These heaters are

shipped open and should not be closed and reopened more than twice. To order, specify **expandable**.

Band Heaters

Special Mica Barrel and Nozzle

Variations

Continued

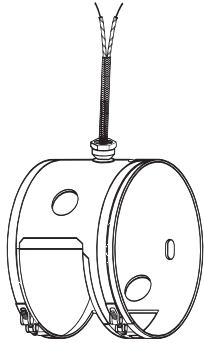

Holes and Notches

An economical way to provide access for instrumentation is to specify an oversize gap between the heater ends. Holes and notches in the sheath should be specified only when all the cylinder surface adjacent to the hole or notch must be heated. Required holes may be provided in nearly any location as

long as there is at least one inch (25 mm) between the hole and one side of the heater. Standard hole sizes up to two inches (51 mm) diameter. For proper hole and/or notch location, a **dimensional drawing or customer supplied sample heater is required.**



Two Piece Band Heaters

Two-piece construction is available on heaters three inches (76 mm) or greater in diameter. Heaters three inches wide or less with post terminals have one terminal on each end. Heaters over three inches wide with post terminals have the two terminals side by side on one end. On two-piece units with leads, also specify the power supply voltage. The power supply voltage is the voltage to

which the heater will be wired. For example, a two-piece band that is 240V~(ac) per half may be wired in series to a 480V~(ac) power supply. In this case the band heater lead wire insulation must be rated for 480V~(ac). To order, specify **two piece band heater, with volts and watts per half and power supply voltage.**

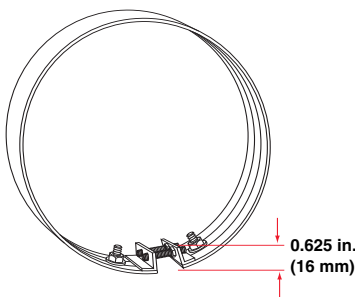

Outside Diameter

This variation is specially designed and constructed to heat the inside diameter of cylinders, i.e., large diameter blown film dies. All the terminations and mounting hardware are located on the I.D. of the heater.

Consult Watlow for available sizes and terminations. To order, specify **outside diameter heater.**

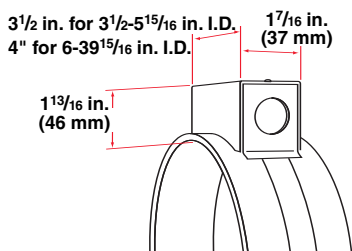

Metallic Terminal Box

Terminal boxes are attached to the heater to cover the terminals for an added safety feature. Conduit may be attached to the box through $\frac{7}{8}$ inch (22 mm) diameter holes in the

ends of the box. Terminal box is available on two-piece heaters. When ordering, specify **terminal box.**

Band Heaters

Special Mica Barrel and Nozzle Variations

Variations

Continued

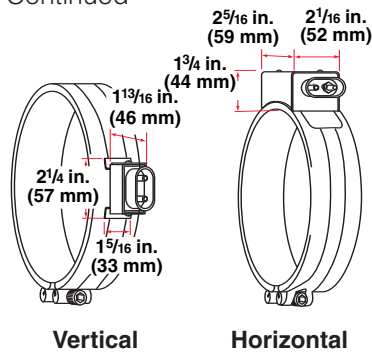

Vertical

Horizontal

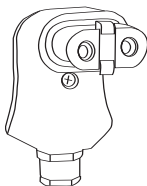

Right Angle

Code # N6027AF049

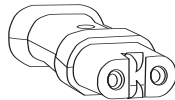

Straight

Code # N6027ZZ028

High Temperature “Quick Disconnect” European Style Plugs

These plugs provide the simplest and safest way to apply power to band heaters. The combination of high temperature male and female quick disconnect plug assemblies eliminates all live exposed terminals

and electrical wiring that can be a potential hazard to employees or machine. Maximum 15 amps at 240V~(ac), maximum 240 volts. To order, specify **vertical** or **horizontal** European plug.

High Temperature “Quick Disconnect” European Style Female Adapters

Available as an accessory item that must be used in conjunction with high temperature “quick

disconnect” European style plugs. Specify code number **N6027AF049** or **N6027ZZ028** and quantity.

Ceramic Terminal Covers

Stock Option

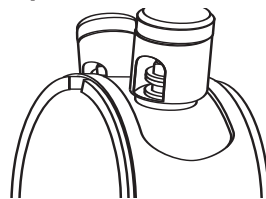

Code # Z-4918

A convenient and economic way to insulate post terminals and are sized for standard length posts. Ceramic terminal covers also have a 10-24 screw thread size. These are supplied as an accessory item and shipped separately. Specify **Z-4918** and quantity.

Special Construction Variations

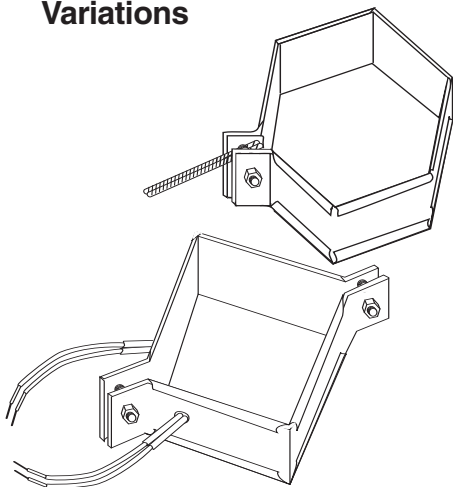

Square, Rectangular and Hex Bands

Square and rectangular heaters are made in either one or two-piece construction. These units are ideal for heating dies on plastic extruders or the barrels of twin screw extruders. Hex-shaped heaters are commonly used on the hex-shaped

portion of the nozzle injection molding machines. Hex-shaped heaters are made to exact customer specifications. To order, specify **square** or **rectangular** heaters. A **dimensional drawing or customer supplied sample heater is required.**

Band Heaters

Special Mica Barrel and Nozzle

Special Construction Variations

Continued

Square, Rectangular and Hex Bands (continued)

Clamping Styles

The preferred clamping style is illustrated in Figure 1 showing bent-up flange clamping. This clamping style applies a uniform clamping force at the corners.

Figure 2 shows bent-up flanges or built-in strapping bracket at the side.

The least preferred clamping style is shown in Figure 3. The one-piece heater does not apply a uniform clamping force.

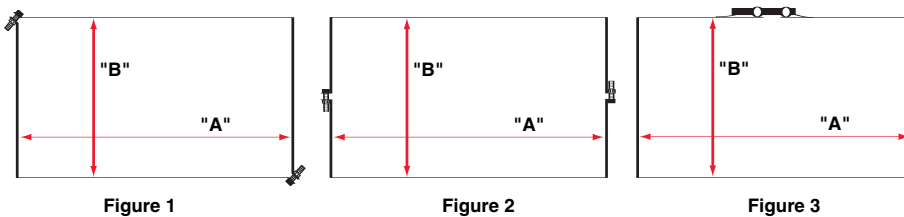

Hinged Two-Piece Band

The hinged, two-piece band heater is connected with a reinforced hinge. It can be opened and closed as often as necessary resulting in easy installation and removal.

To order, specify **hinged two-piece band** and watts and volts per each half.

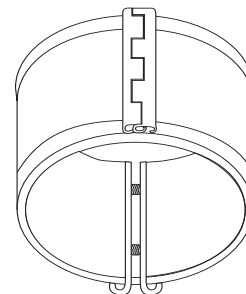

Thermocouple Bracket

The thermocouple bracket simplifies the installation of an external thermocouple with a bayonet adapter. The standard location for the adapter is 90 degrees from the gap. Sizes available are $\frac{1}{8}$ (3.18 mm), $\frac{1}{4}$ (6.3 mm) and $\frac{3}{8}$ (9.53 mm)

To order, specify **thermocouple bracket**.

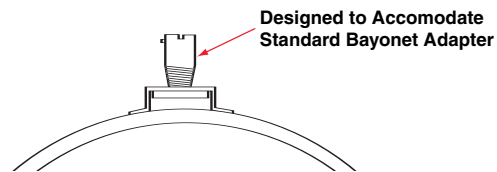

Band Heaters

Special Mica Barrel and Nozzle

Special Construction Variations

Continued

Cone Shapes

Cone shaped heaters are ideal for applications where heat is required for hoppers or funnels. The preferred method of attachment is with bent-up flange clamping. Cone shaped heaters are made to exact customer specifications.

To order, specify **cone shape adapter**. A **dimensional drawing or customer supplied sample heater is required**.

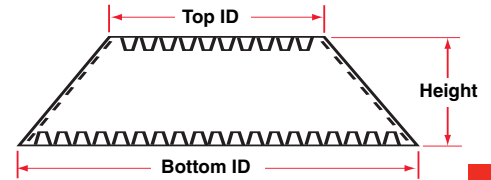

Clamping Variations

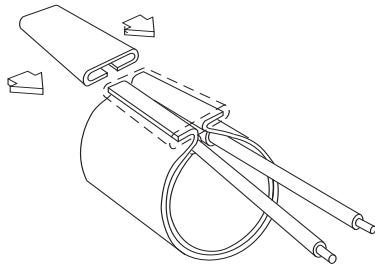

HV Wedge-Lok

HV wedge-lok is designed to provide excellent clamping where mounting space is limited. It is available with Type A and L leads only. Clearance from I.D. of the heater to the outside edge of the wedge-lok is $\frac{5}{16}$ inch (8 mm) nominal. Available on certain sizes from stock. To order, specify **HV wedge-lok**.

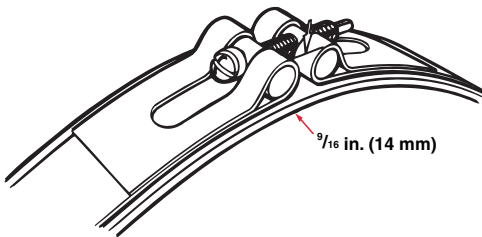
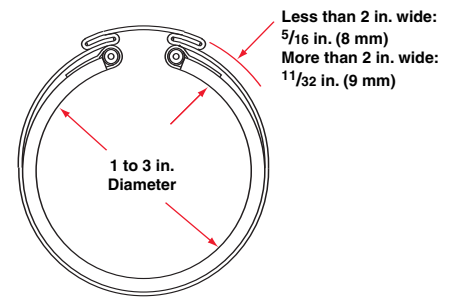

Standard and Low-Profile Clamping Strap

The standard clamping strap requires $\frac{9}{16}$ inch (14 mm) clearance above the heated surface, at the barrel nuts. When clearance is limited, smaller barrel nuts can be used which require only $\frac{3}{8}$ inch (9 mm) clearance. The clearance required by the clamping screw

depends on the screw length and the diameter of the heater. The low-profile clamping strap is standard on units less than 1 $\frac{3}{8}$ inches (45 mm) wide and utilizes a $\frac{1}{2}$ inch (13 mm) wide strap. Consult Watlow for more information. To order, specify **low-profile clamping strap**.

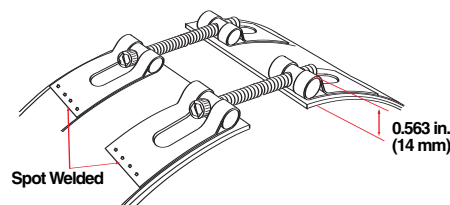

Welded Barrel Nuts

An ideal way to provide access for instrumentation is to specify an oversized gap between the heater ends. If the clamp strap interferes with the positioning of the instrumentation device,

welded barrel nuts are recommended. Maximum gap is one inch (25 mm). Specify **welded barrel nuts with dimensional location and gap dimension** when ordering.

Band Heaters

Special Mica Barrel and Nozzle Clamping Variations

Clamping Variations

Continued

Non-Stock Option

Clamping Tabs

Tabs—or lock-up flanges—are available. However, the special mica band heater and strap design provides superior clamping and improved heat transfer and should be used whenever possible. To order, specify **clamping tabs**.

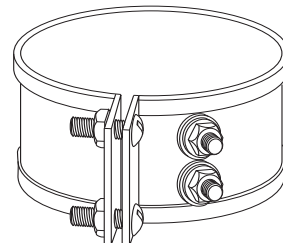

Clamping Pads

Clamping pads have a hole to allow easy fastening to machine barrel. Clamping pads are used when an obstruction hinders a standard clamping strap from fitting completely around the machine barrel.

To order, specify **clamping pads** and **degrees coverage**.

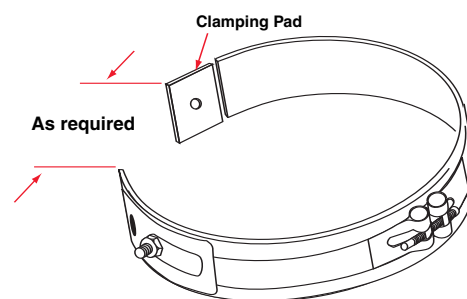

Termination Variations

Post Terminal Options

Standard post terminals have a threaded length of $\frac{7}{16}$ inch (11 mm) and require $\frac{3}{4}$ inch (19 mm) clearance from the cylinder. Terminals with $\frac{1}{2}$ inch (17 mm) threaded lengths are available that require one inch of clearance. Button terminals require only $\frac{7}{16}$ inch (11 mm) clearance. Maximum amperage for post terminals is 35 amps. To order, specify **standard**, **long** or **button** terminals.

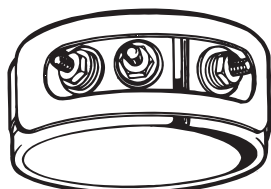
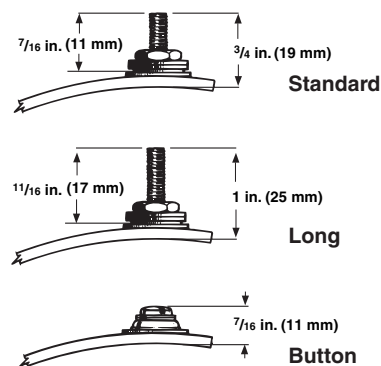

Three-Phase or Dual Voltage

A third terminal can be added to provide dual voltage or three-phase.

Standard terminal location on heaters three inches (76 mm) wide or less is one terminal at each end of the heater centered on the width.

On heaters three inches wide or wider, the terminals are located side-by-side on one end. Special terminal locations are available. To order, specify **dual voltage** or **three-phase**.

Band Heaters

Special Mica Barrel and Nozzle Termination Variations

Termination Variations

Continued

Heaters rated at less than 250 volts use UL® approved lead insulation for operations to 250°C (482°F) as standard. Lead insulation UL® rated for operation to 450°C (850°F) may be required in high temperature applications where the leads are shrouded or enclosed with the heater. All heaters rated at more than 250V~(ac) use this wire.

Type B

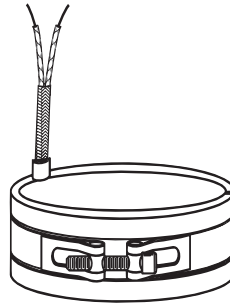

Two fiberglass-insulated lead wires exit in a single metal braid for good abrasion protection, lead flexibility and wiring convenience. Leads are two inches (51 mm) longer than braid. To order, specify **Type B** and **length**.

Type C

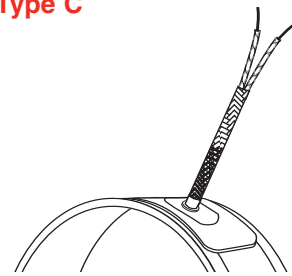

Two fiberglass lead wires exit a single tightly woven metal braid for good abrasion protection, lead flexibility and wiring convenience. Leads are two inches (51 mm) longer than the braid. To order, specify **Type C** and **length**.

Type E

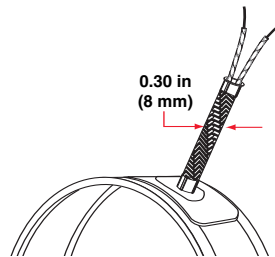

Loose metal braid encloses two fiberglass leads for good abrasion protection, lead flexibility and wiring convenience. Leads are two inches (51 mm) longer than the braid. To order, specify **Type E** and **length**.

Type F

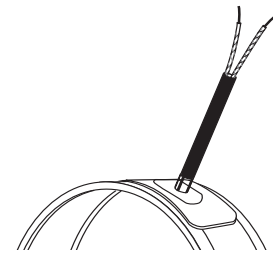

Loose fiberglass sleeving encloses two fiberglass leads for additional insulation protection where high temperature or minor abrasion is present. Leads are two inches (51 mm) longer than the sleeving. To order, specify **Type F** and **length**.

Type H

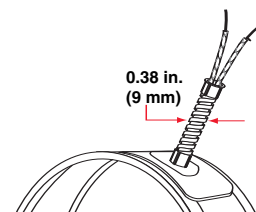

A stainless steel, flexible conduit encloses the leads for superior mechanical protection where lead abrasion is a particular problem. Leads are two inches (51 mm) longer than the conduit. To order, specify **Type H** and **length**.

Type K

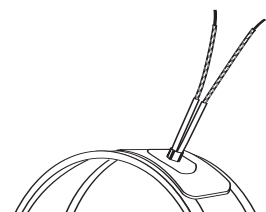

Flexible lead wires exit vertically from the heater. These leads can be bent adjacent to the heater for a quick and easy connection. To order, specify **Type K** and **length**.

Band Heaters

Special Mica Barrel and Nozzle

Termination Variations

Continued

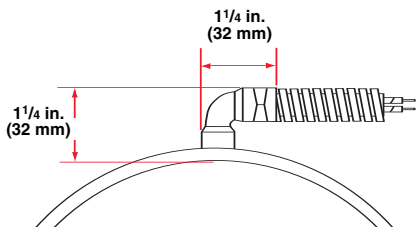

Right Angle Armor Cable

Armor cable provides superior protection to lead wires where abrasion can cause damage. The standard leads are 12 inches (304.8 mm) of armor cable over 14 inches (355.6 mm) of flexible

leads. Right angle armor cable is available on any clamping or construction variation.

To order, specify **right angle armor cable**.

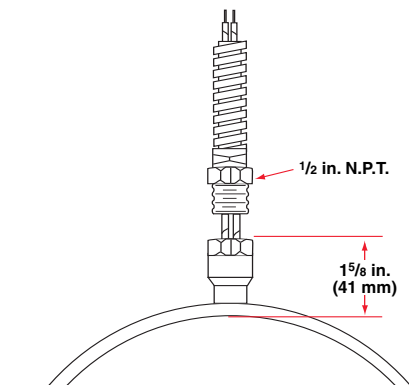

Removable Armor Cable

Removable armor cable is recommended on applications where removable armor is required. It is available on any clamping or construction variation. The fitting will

accept the standard armor cable connector. The standard flexible leads are 14 inches (355.6 mm).

To order, specify **removable armor cable**.

Installation Procedures

1. Install heaters over a clean surface.
2. Install clamp straps, tightening until screw cannot be tightened additionally. On heaters with multiple straps, alternately tighten each strap until no additional tightening occurs.
3. To insure that the heater is properly seated on the barrel, it is advisable to tap around the circumference of heater with a soft mallet. This will result in a final conforming of the heater to the cylinder. Generally after this is done, operators can get an additional turn or two on the

clamp screw. Each screw should have an ultimate torque value as in below chart.

4. When installing terminal lugs, torque the top nut to 12 in.-lbs. The bottom nut should be held by a wrench when tightening the top nut.
5. After the machine has been run for its initial heat up, it is advisable to retighten the clamping bands.

Note: This retightening must be done when the heaters are cold. If the heater becomes loose due to normal operating and cycling the strap can be retightened, although frequent adjustments are not advisable. It is advisable to check bands for tightness every three to four months.

Clamp Strap Torque Specifications

Strap Width in. (mm)	Strap Screw	Allen Type	Pan Head Type
3/8 (22.2)	10 - 24	60 - 75 lb/in	30 - 35 lb/in
5/8 (15.8)	10 - 24	30 - 35 lb/in	30 - 35 lb/in
1/2 (12.7)	8 - 32	25 lb/in	25 lb/in